

# Tube Heater Parts Instruction Sheet

## TP-264B Burner Pressure Switch Replacement

### INSTRUCTIONS FOR HEATERS WITH DUAL PRESSURE SWITCHES

#### Contents

- TP-264B Normally Open Pressure Switch (IS2F5166).
- 20 in. Vinyl Sensing Tube (Field cut to size).
- Insect Resistant Brass Barbs (Qty. 2).

#### Replaces

- TP-61B (PPS-2550)
- TP-61A (FP4306)

This replacement part may be used on the following models:

**Dual Switch Models** (Normally Open Burner Switch) Manufactured prior to 06/03

DTH(-2), DTHS(-2), HL, HL-2, DX, DX-2, XTS, RVA (50,000 to 100,000 BTU/H models)

#### Dual Switch Installation Instructions

- 1 Disconnect electrical supply voltage to the heater.
- 2 Remove faulty switch from the fan compartment.
- 3 Connect the negative (-) marker barb to the vinyl tube connected to the atmospheric brass barb (ducted outside the burner box).
- 4 Connect the positive (+) marked barb to the vinyl tube (Figure 1).
- 5 Reassemble the switches on the center divide panel using one mounting hole on the new IS2 pressure switch.
- 6 Ensure that the vinyl tube(s) have a smooth radius bend and that there are no obstructions, bends or kinks.
- 7 Reconnect the spade terminals to COM and N.O.
- 8 Reconnect the electrical power supply voltage.

**Figure 1** • Burner switch replacement for heaters with dual switches.

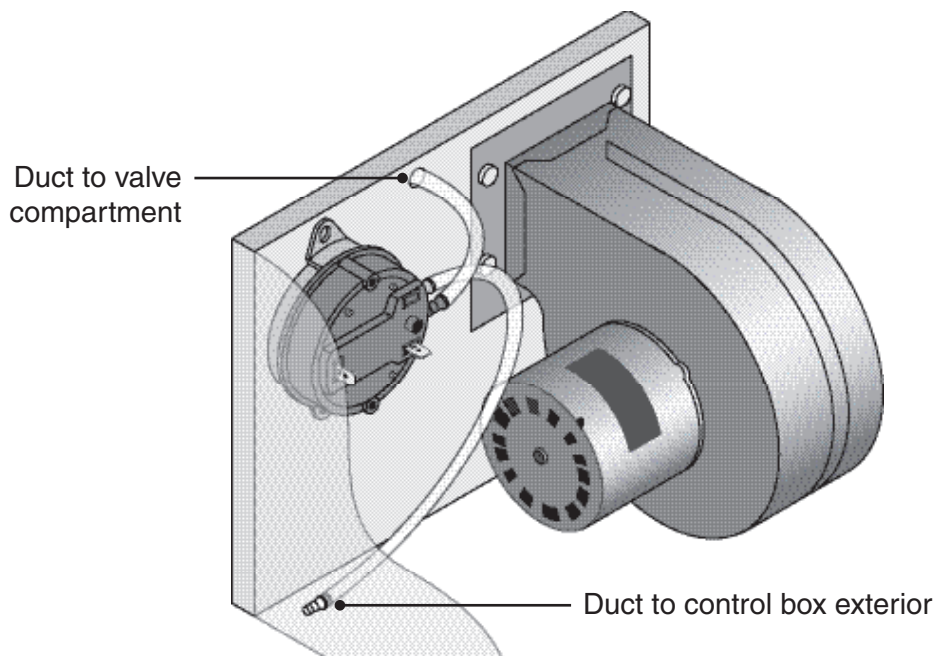

#### NOTICE



This figure illustrates a dual pressure switch configuration when the TP-264B serves as the normally open burner switch wired upstream of the normally closed exhaust switch.

# Tube Heater Parts Instruction Sheet

## TP-264B Differential Switch Replacement

### INSTRUCTIONS FOR HEATERS WITH A SINGLE SWITCH

#### Contents

- TP-264B Normally Open Pressure Switch (IS2F5166).
- 20 in. Vinyl Sensing Tube.
- Insect Resistant Brass Barbs (Qty. 2).

#### Replaces

TP-61B (PPS-2550)

This replacement part may be used on the following models:

**Single Switch Models** (Differential Switch Located in the Valve Compartment) Manufactured 06/03 - 05/05\*

HL2, DX2, XTS, DET, DES & RH (50-100 MBH), RVA2, AG2 & AG1 (50-75 MBH), SV & HLV (50-80 MBH)

\*Differential switch for models manufactured 05/05 to present is located in the fan compartment.

#### Single Switch Installation Instructions

- 1 Disconnect electrical supply voltage to the heater.
- 2 Remove faulty switch from the valve side compartment.
- 3 Connect the 20 in. vinyl sensing tube to the new IS2 pressure switch barb fitting marked (-).
- 4 Reassemble the switch on the center divide panel using one mounting hole on the new IS2 pressure switch.
- 5 Ensure that the vinyl tube has a smooth radius bend and that there are no obstructions, bends or kinks.  
**NOTE:** Place vinyl hose below gas valve and away from burner inlet.
- 6 Reconnect the spade terminals to COM and N.O.
- 7 Replace the control box cover.
- 8 Reconnect the electrical power supply voltage.

**Figure 2** • Differential switch replacement for heaters with a **single switch** located in valve compartment.

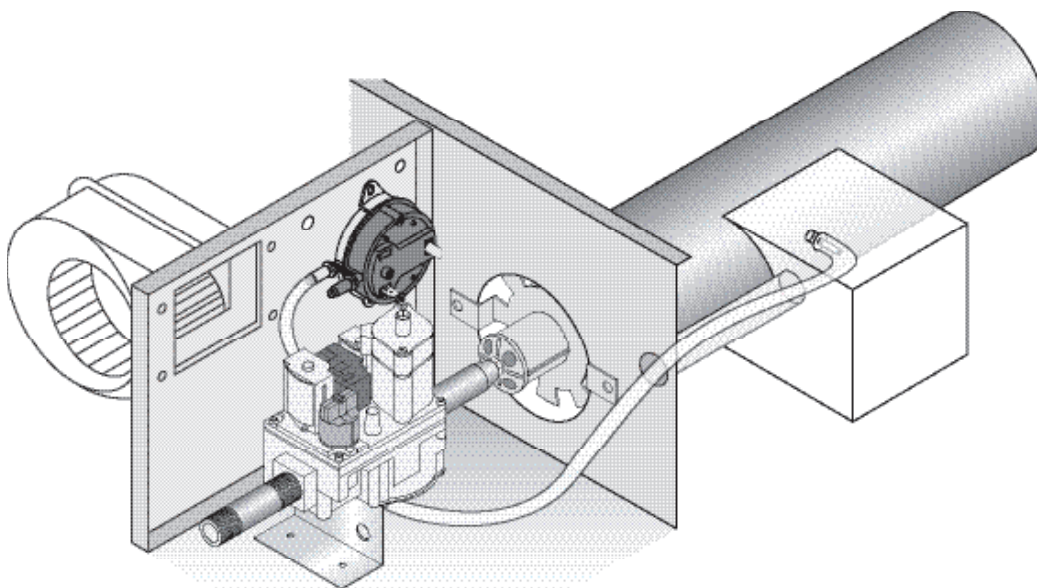

#### **NOTICE**



This figure illustrates models with a single “differential” pressure switch configuration manufactured between 6/03 and 5/05 where the switch is located in the valve compartment.