

Tube Heater Parts Instruction Sheet

Hot Surface Igniter Glo-Bar™ Installation

For heaters with a tube mounted hot surface igniter:

(See reverse for DTH(S), DBS and DRV Series heaters)

Parts List

- TP-50 Silicone Carbide Hot Surface Igniter Glo-Bar™ (Heaters with 120V ignition).
- TP-1250 24V Mini Igniter (HLV and SV Series heaters only).

Installation Instructions

- 1 Disconnect electrical supply voltage to the heater.
- 2 Remove cover from igniter box.
- 3 Unplug igniter from wiring harness.
- 4 **A.** (TP-50) With your index finger and thumb, grasp the loop on the igniter spring clip. Pull back, then down.
B. (TP-1250) Remove mounting screw from igniter. **NOTE:** This screw also mounts the flame rod.
- 5 Carefully remove the igniter.
- 6 Install the new igniter by reversing steps 1 through 5.

Figure 1 • Heater with Tube Mounted Hot Surface Igniter

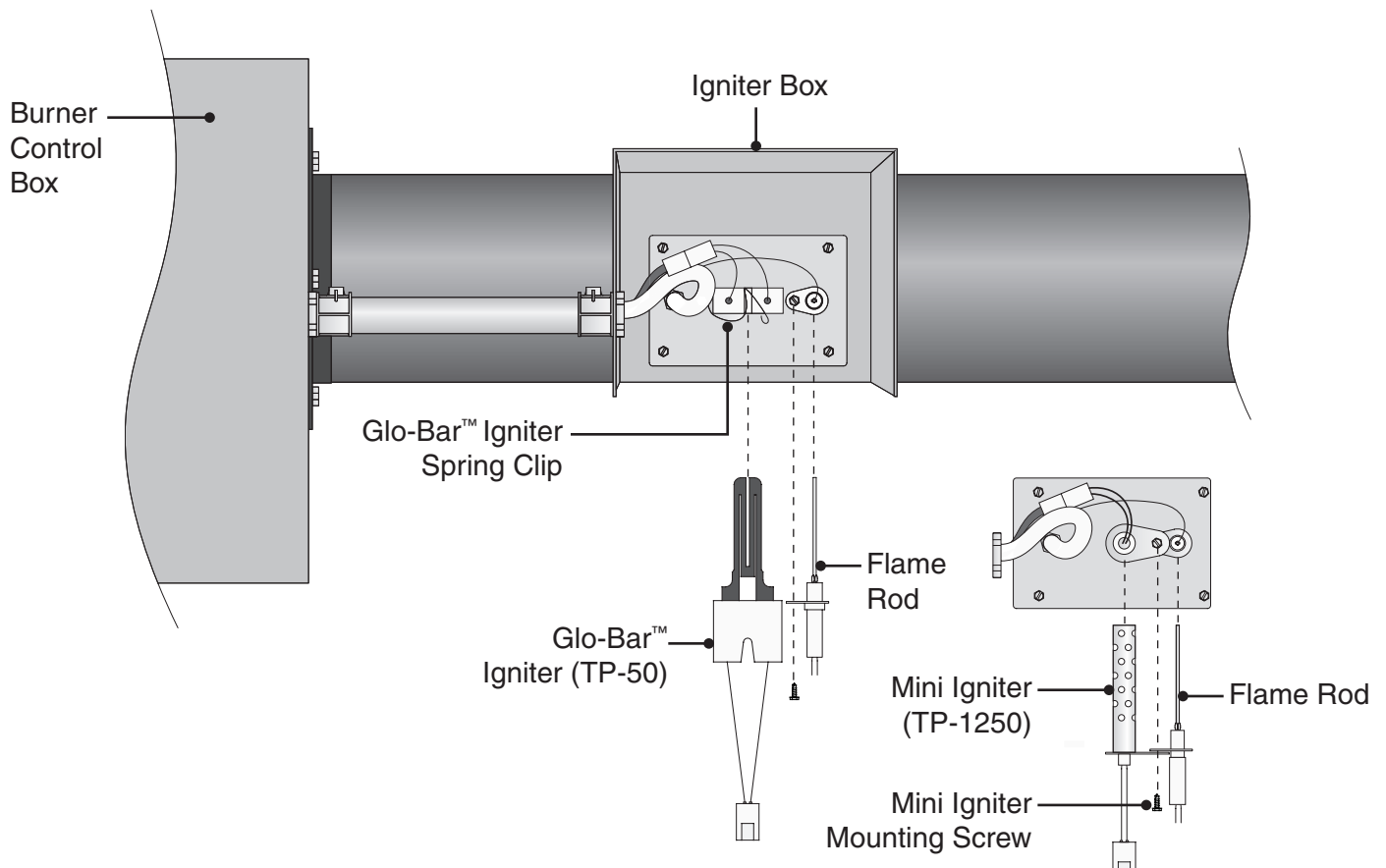

Tube Heater Parts Instruction Sheet

Hot Surface Igniter Installation

For DTH(S), DBS and DRV Series models only.

Parts List

- TP-50 Silicone Carbide Hot Surface Glo-Bar™ Igniter (DTH(S) & DBS Series)
- V-50 Silicone Carbide Hot Surface Glo-Bar™ Igniter (DRV Series)

Installation Instructions

- 1 Turn off gas and electrical supply to the heater.
- 2 Remove burner control box cover.
- 3 Unplug wire **A** to the Glo-Bar™ igniter (Figures 3a-b). Remove nut **B** (Figure 3a) or disconnect the 3-piece union (Figure 3b) and slide the control assembly back. Unscrew bolts **C** fastening the orifice bracket to the control box. Rotate the burner assembly 90° counter-clockwise to remove.
- 4 Remove screws **D** from the top of the burner housing to pull out the burner (Figure 4).
- 5 Remove the screw **E** holding the faulty Glo-Bar™ igniter to the burner.
- 6 Carefully install the new igniter by reversing steps 1 through 5. Insert the burner assembly with the igniter at a 12 o'clock position to avoid breaking the replacement.

Figure 2 • DTH(S) Burner Control Box

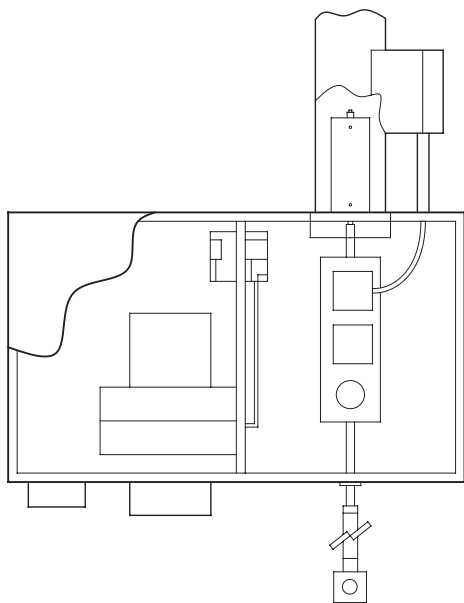

Figure 3a • Control Assembly Nut

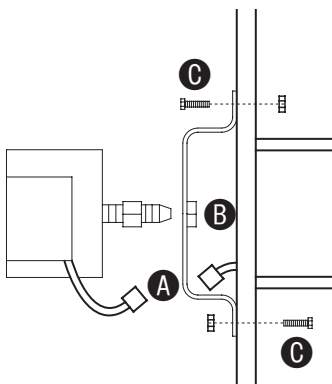

Figure 3b • Control Assembly 3-Piece Union

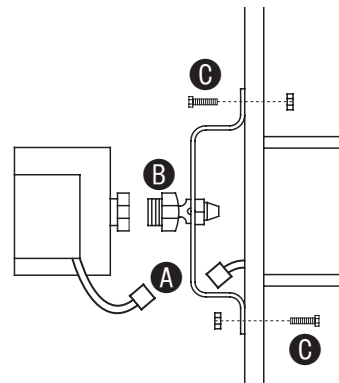

Figure 4 • Burner Housing

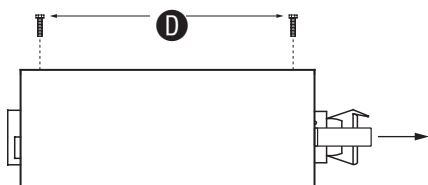

Figure 5 • Glo-Bar™ Installation

