

Tube Heater Parts Instruction Sheet

TP-264E Burner Pressure Switch Replacement

INSTRUCTIONS FOR HEATERS WITH DUAL PRESSURE SWITCHES

Contents

- TP-264E Normally Open Pressure Switch (IS2F5169).
- 20 in. Vinyl Sensing Tube.
- Insect Resistant Brass Barbs (Qty. 2).

Replaces

TP-61E (PPS-3050)

This replacement part may be used on the following models:

Dual Switch Models (Normally Open Burner Switch)

LS (25 MBH)

Dual Switch Installation Instructions

- 1 Disconnect electrical supply voltage to the heater.
- 2 Remove faulty switch from the fan compartment.
- 3 Connect the negative (-) marker barb to the vinyl tube connected to the atmospheric brass barb (ducted outside the burner box).
- 4 Connect the positive (+) marked barb to the vinyl tube (Figure 1).
- 5 Reassemble the switches on the center divide panel using one mounting hole on the new IS2 pressure switch.
- 6 Ensure that the vinyl tube(s) have a smooth radius bend and that there are no obstructions, bends or kinks.
- 7 Reconnect the spade terminals to COM and N.O.
- 8 Reconnect the electrical power supply voltage.

Figure 1 • Burner switch replacement for heaters with dual switches.

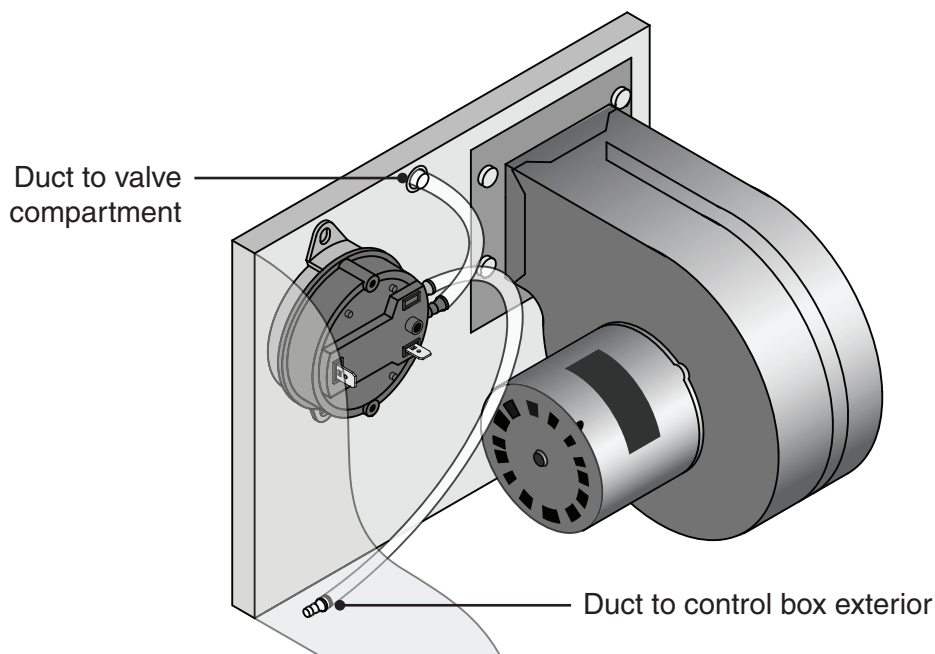

NOTICE



This figure illustrates a dual pressure switch configuration when the TP-264E serves as the normally open burner switch wired upstream of the normally closed exhaust switch.

Tube Heater Parts Instruction Sheet

TP-264E Differential Switch Replacement

INSTRUCTIONS FOR HEATERS WITH A SINGLE SWITCH

Contents

- TP-264E Normally Open Pressure Switch (IS2F5169).
- 20 in. Vinyl Sensing Tube.
- Insect Resistant Brass Barbs (Qty. 2).

Replaces

TP-61E (PPS-3050)

This replacement part may be used on the following models:

Single Switch Models (Differential Switch Located in the Valve Compartment) Mfg 06/03 - 05/05*

HL2, DX2, XTS, DET, DES & RH (125-150 MBH), RVA2, AG2 , AG1 & SV (100-125 MBH), HLV (90-125 MBH), XTS(-3) & DES(-3) (50 MBH)

*The differential switch for models manufactured 05/05 to present is located in the fan compartment with the exception of (-3) models.

Single Switch Installation Instructions

- 1 Disconnect electrical supply voltage to the heater.
- 2 Remove faulty switch from the valve side compartment.
- 3 Connect the 20 in. vinyl sensing tube to the new IS2 pressure switch barb fitting marked (-).
- 4 Reassemble the switch on the center divide panel using one mounting hole on the new IS2 pressure switch.
- 5 Ensure that the vinyl tube has a smooth radius bend and that there are no obstructions, bends or kinks.
NOTE: Place vinyl hose below gas valve and away from burner inlet.
- 6 Reconnect the spade terminals to COM and N.O.
- 7 Replace the control box cover.
- 8 Reconnect the electrical power supply voltage.

Figure 2 • Differential switch replacement for heaters with a single switch will be located in valve or fan compartment.

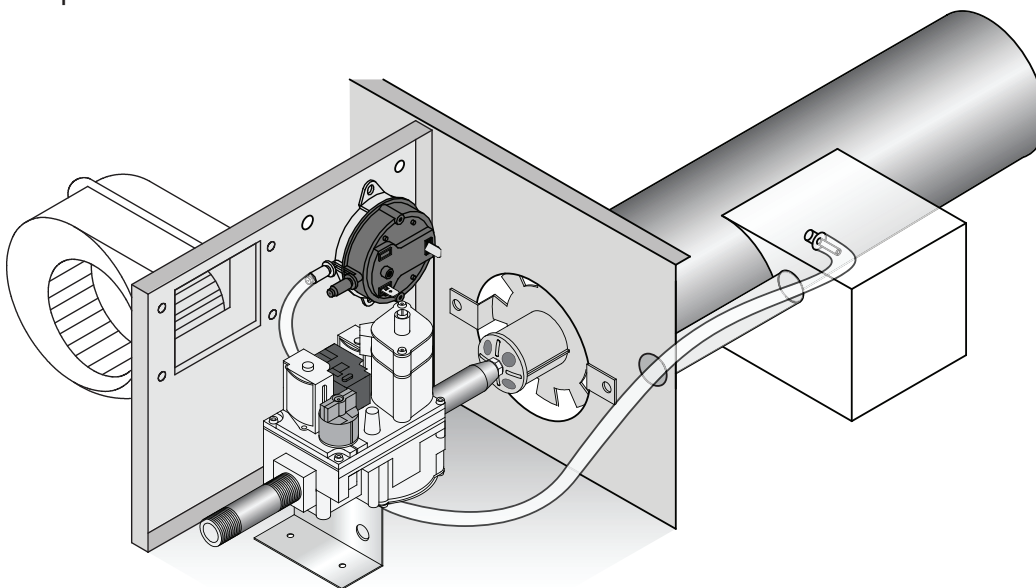

NOTICE



This figure illustrates models with a single “differential” pressure switch configuration manufactured 6/03 to 5/05 where the switch is located in the valve compartment.