

# DETROIT RADIANT PRODUCTS CO.

## White-Rodgers TH-1F95 Thermostat



**Range**  
45°F to 99°F

**Differential**  
0.5°F to 1.5°F

**Contact Action**  
Opens on rise

**Electrical Rating**  
24V-20 to 30 VAC  
1.5 AMP per terminal  
2.5 AMP max terminal sum

**Dimensions**  
Height: 4.125"  
Width: 6.875"  
Depth: 1.375"

**Operation**  
Two-stage  
Single-stage  
with remote  
sensing capability

### Additional Features

- 7 day programming.
- Operate up to 30 two-stage heaters with HLRB boards & transformers.
- Operate two complete vacuum systems.

### Remote Sensor

- RS-F145
- Up to 200' remote sense.
- For indoor use only.

### TYPICAL WIRING DIAGRAMS

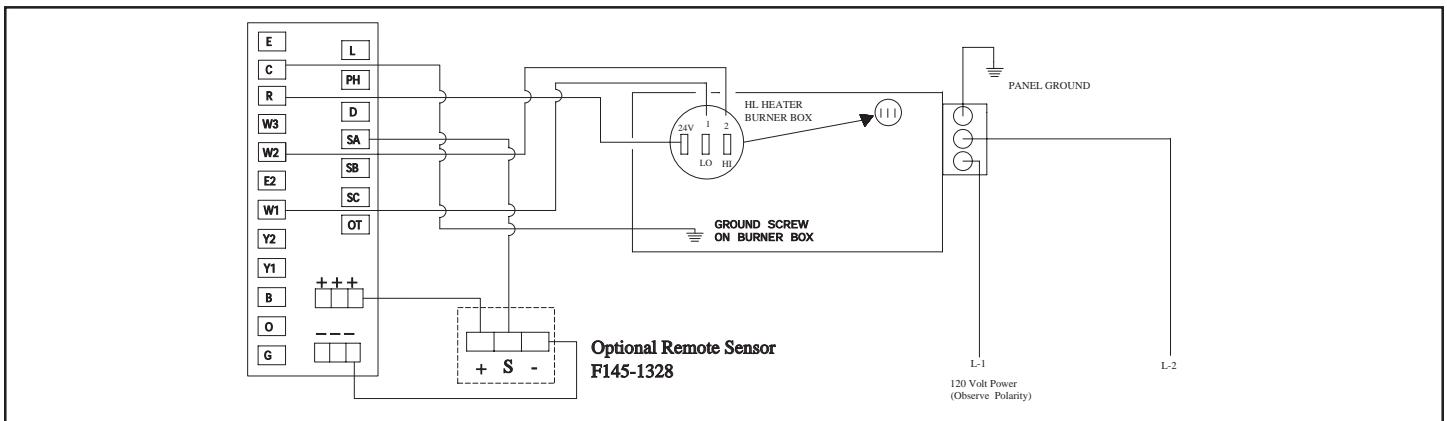

Two-stage heaters with a TH-1F95 thermostat. Single heater, single thermostat. No HLRB (relay board) is installed.

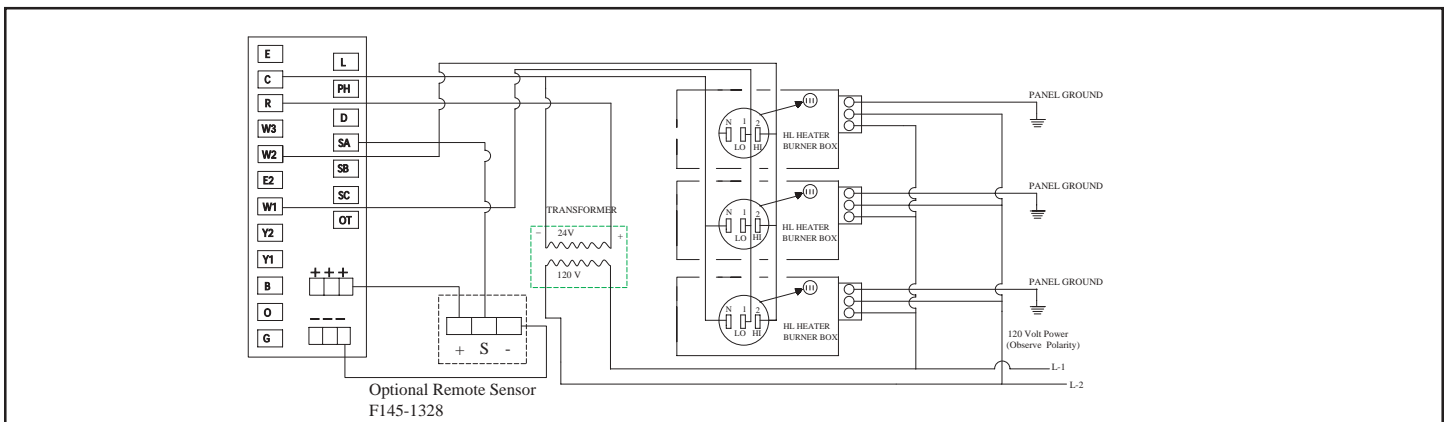

Two-stage heaters with a TH-1F95 thermostat. Single heater, single thermostat. HLRB (relay boards) are installed.



Printed in U.S.A.  
© 2006 Detroit Radiant Products Co.  
21400 Hoover Rd., Warren, MI 48089  
T. (586) 756-0950 F. (586) 756-2626  
www.detroitradiant.com  
Form# LSH072-4/06 (DRP)