

DETROIT RADIANT

RE-VERBER-RAY

RADIANT GAS HEATERS®

PRODUCTS COMPANY

COMMERCIAL & INDUSTRIAL

SERIES

○ HL3

● DX3

○ XTS3

○ DET3

○ DES3

DX3 SERIES

GAS-FIRED, SINGLE STAGE, INFRARED HEATERS

Packed with quality features, the DX3 represents the highest in quality, single stage, low intensity tube heaters. Performance is enhanced through the use of a specially designed stainless steel burner and black coated titanium stabilized and/or aluminized coated steel radiant tube exchangers. The DX3 Series offers superior low intensity heat, performance and longevity.

PRODUCT FEATURES

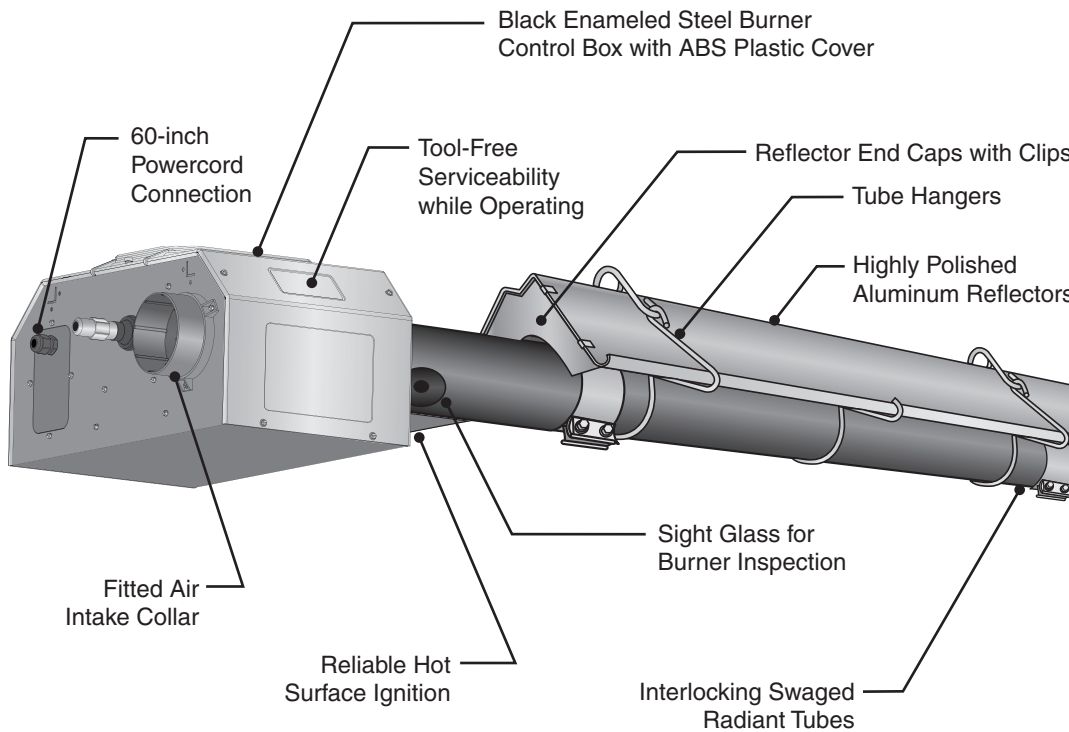

SPECIFIC FEATURES



- Tool-free access to controls.
- Serviceability while unit is operating.
- Separated air and gas burner chamber.
- Symmetrical placement of ignition tube.
- Hinged control compartment provides ease in servicing.
- 3-piece independent compartment cover.
- ABS plastic air intake collar for connection to 4" PVC/DWV pipe.

PRODUCT FEATURES COMPARISON CHART

	HL3	DX3	XTS3	DET3	DES3
Highly Polished Aluminum Reflectors	•	●	•	•	•
Coated Titanium or Aluminized Combustion Chamber	•	●	•	•	•
Coated Aluminized Radiant Tubes	•	●	•	•	•
Hot Surface Ignition	•	●	•	•	•
Stainless Steel Flexible Gas Connector	•	●	•	•	•
Ball Valve (1/2" Brass) with Pressure Tap Included	•	●	•	•	•
Two-stage Technology	•	•	•	•	•
Interlocking Swaged Tubes	•	●	•	•	•
Stainless Steel Models Available*	•	●	•	•	•
Reflector End Caps	•	●	•	•	•
Optional 'U' or 'L' Configurations Available	•	●	•	•	•

* Select upgrades available; full stainless models are available in the HL2 and DX2 Series offering.

DETROIT RADIANT PRODUCTS CO.

21400 Hoover Rd.
Warren, MI 48089-3162

Phone: (586) 756-0950
Toll Free: 1-800-222-1100
Fax: (586) 756-2626
E-mail: sales@drp-co.com
Website: www.reverberray.com

VISIT OUR WEBSITE FOR:

- Product Specs
- Parts Support
- Dealer Locator
- Applications
- C.A.D. Library
- Design Guidelines
- Theory of Infrared
- and More!

DX3 SERIES

SPECIFICATIONS

PRODUCT SPECIFICATIONS

BTU Range:	50,000 to 200,000 BTU/h
Lengths:	20-80 Ft.
Gas Type:	Natural or Propane
Combustion Chamber:	Titanium Stabilized or Aluminized Steel
Radiant Tubes:	Coated Aluminized Steel
Certification:	CSA, IAS
Limited Warranty:	1-5-10 (Components-Tubes-Burner)

OPTIONAL EQUIPMENT

U or L Configurations:	Available (RUP, REP)
Stainless Steel Upgrades:	Available (SSTRAO, SSFWAO)
24V Controls:	Available (24VAO)
Indicator Lights:	Standard
Protective Guards:	Available (PG)
Side Shield Extensions:	Available (SSE)
Outdoor Approval:	Available (OD-KIT)



ELECTRICAL

- 120V, 60Hz, 3-wire.
- 4.8A starting, 1.1A running.

CONTROLS

- Pre-purge.
- Potted circuitry.
- 120V thermostat control.

TUBE CONSTRUCTION

- As shown to left.
- 4" x 10' 16 ga. construction.
- Labor saving, interlocking swaged tube design.

REFLECTORS

- Highly polished aluminum.
- End caps included.
- 0° – 45° rotatable angle.
- Tension springs.

IGNITION/SENSE

- Hot surface ignition.
- Flame rod sense.

VENTING

- 4" single vent.
- 6" common vent (single t-stat).
- SK caps on 200 MBH models.

GAS CONNECTION

- 1/2" NPT ball valve/inlet tap included.
- 24" stainless steel flexible connector included.

GAS PRESSURES

- MAN. - 3.5" NAT or 10.0" LP
- MIN. - 5.0" NAT or 11.0" LP
- MAX. - 14.0" NAT or 14.0" LP

COMBUSTION AIR

- Equipped for ducted air intake from roof or sidewall.

KIT CONTENTS

- All hangers & couplers.
- Reflector end caps.
- Turbulator baffles.

AVAILABLE DX3 MODELS & CLEARANCES

MODEL #	GAS*	INPUT BTU/h	LENGTH	WEIGHT	MOUNTING HEIGHTS**
DX3-20-50	N or LP	50,000	21'-9"	120 lbs.	9' to 14'
DX3-20-60	N or LP	60,000	21'-9"	120 lbs.	10' to 15'
DX3-20-75^	N or LP	75,000	21'-9"	120 lbs.	11' to 18'
DX3-30-50	N or LP	50,000	31'-5"	160 lbs.	10' to 15'
DX3-30-60	N or LP	60,000	31'-5"	160 lbs.	11' to 18'
DX3-30-75^	N or LP	75,000	31'-5"	160 lbs.	12' to 20'
DX3-30-100^	N or LP	100,000	31'-5"	160 lbs.	13' to 23'
DX3-30-125^	N or LP	125,000	31'-5"	160 lbs.	14' to 25'
DX3-40-50	N or LP	50,000	41'-1"	190 lbs.	11' to 18'
DX3-40-60	N or LP	60,000	41'-1"	190 lbs.	11' to 18'
DX3-40-75^	N or LP	75,000	41'-1"	190 lbs.	12' to 20'
DX3-40-100^	N or LP	100,000	41'-1"	190 lbs.	13' to 23'
DX3-40-125^	N or LP	125,000	41'-1"	190 lbs.	14' to 25'
DX3-40-150^	N or LP	150,000	41'-1"	190 lbs.	15' to 27'
DX3-40-175	N or LP	175,000	41'-1"	190 lbs.	16' to 30'
DX3-50-100^	N or LP	100,000	50'-9"	235 lbs.	15' to 27'
DX3-50-125^	N or LP	125,000	50'-9"	235 lbs.	15' to 27'
DX3-50-150^	N or LP	150,000	50'-9"	235 lbs.	16' to 30'
DX3-50-175	N or LP	175,000	50'-9"	235 lbs.	17' to 35'
DX3-50-200	N or LP	200,000	50'-9"	235 lbs.	18' to 40'
DX3-60-125	N or LP	125,000	60'-5"	265 lbs.	16' to 30'
DX3-60-150^	N or LP	150,000	60'-5"	265 lbs.	17' to 35'
DX3-60-175	N or LP	175,000	60'-5"	265 lbs.	17' to 35'
DX3-60-200	N or LP	200,000	60'-5"	265 lbs.	18' to 40'
DX3-70-175	N or LP	175,000	70'-1"	300 lbs.	19' to 42'
DX3-70-200	N or LP	200,000	70'-1"	300 lbs.	19' to 42'
DX3-80-200	N or LP	200,000	79'-9"	330 lbs.	20' to 45'

* Specify natural (N) or propane (LP) gas. **Mounting heights are provided as a guideline. Actual conditions may dictate variations from the above data. ^Stainless steel tube upgrades available.

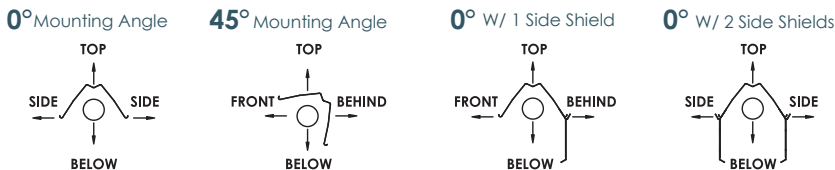

DX3 CLEARANCES TO COMBUSTIBLES (IN.)

MODEL NO.	MOUNTING ANGLE	SIDE			
		FRONT	BEHIND	TOP	BELOW
DX3-(20,30,40)-(50,60)	0°	9	9	6	47
	45°	39	8	10	47
W/1 Side Shield	0°	29	8	6	47
W/2 Side Shields	0°	9	9	6	47
20 ft. from Burner	0°	7	7	6	30
DX3-(20,30,40)-75	0°	9	9	6	60
	45°	39	8	10	60
W/1 Side Shield	0°	29	8	6	60
W/2 Side Shields	0°	9	9	6	60
20 ft. from Burner	0°	7	7	6	30
DX3-(30,40,50)-100	0°	14	14	6	66
	45°	39	8	10	66
W/1 Side Shield	0°	29	8	6	66
W/2 Side Shields	0°	16	16	6	66
20 ft. from Burner	0°	7	7	6	30
DX3-(30,40,50,60)-125	0°	20	20	6	76
	45°	58	8	10	76
W/1 Side Shield	0°	42	8	6	76
W/2 Side Shields	0°	20	20	6	76
20 ft. from Burner	0°	7	7	6	30
DX3-(40,50,60)-150	0°	24	24	6	81
	45°	58	8	10	81
W/1 Side Shield	0°	42	8	6	81
W/2 Side Shields	0°	23	23	6	81
20 ft. from Burner	0°	11	11	6	44
DX3-(40,50,60,70)-175	0°	34	34	6	92
	45°	63	8	10	92
W/1 Side Shield	0°	50	8	6	92
W/2 Side Shields	0°	30	30	6	92
20 ft. from Burner	0°	11	11	6	44
DX3-(50,60,70,80)-200	0°	41	41	6	94
	45°	63	8	10	94
W/1 Side Shield	0°	54	8	6	94
W/2 Side Shields	0°	30	30	6	94
20 ft. from Burner	0°	11	11	6	44

Always maintain the published clearances to combustibles.

Clearances published in DX3 Series manual and on warning label supersede data shown on this brochure.

DISTRIBUTED BY:

