

DETROIT RADIANT

RE-VERBER-RAY

RADIANT GAS HEATERS®

PRODUCTS COMPANY

COMMERCIAL & INDUSTRIAL

SERIES

● HL3 ○ DX3 ○ XTS3 ○ DET3 ○ DES3

HL3 SERIES

GAS-FIRED, TWO STAGE, INFRARED HEATERS

The HL3 Series, packed with quality features, represents today's most energy efficient line of infrared tube heaters. Our patented two stage technology, incorporated into the HL3 Series, provides more comfort while saving valuable energy dollars. In addition, the highest quality materials and construction features ensure years of reliable and efficient operation. No other infrared heater can match the performance and quality of the HL3 Series.

PRODUCT FEATURES

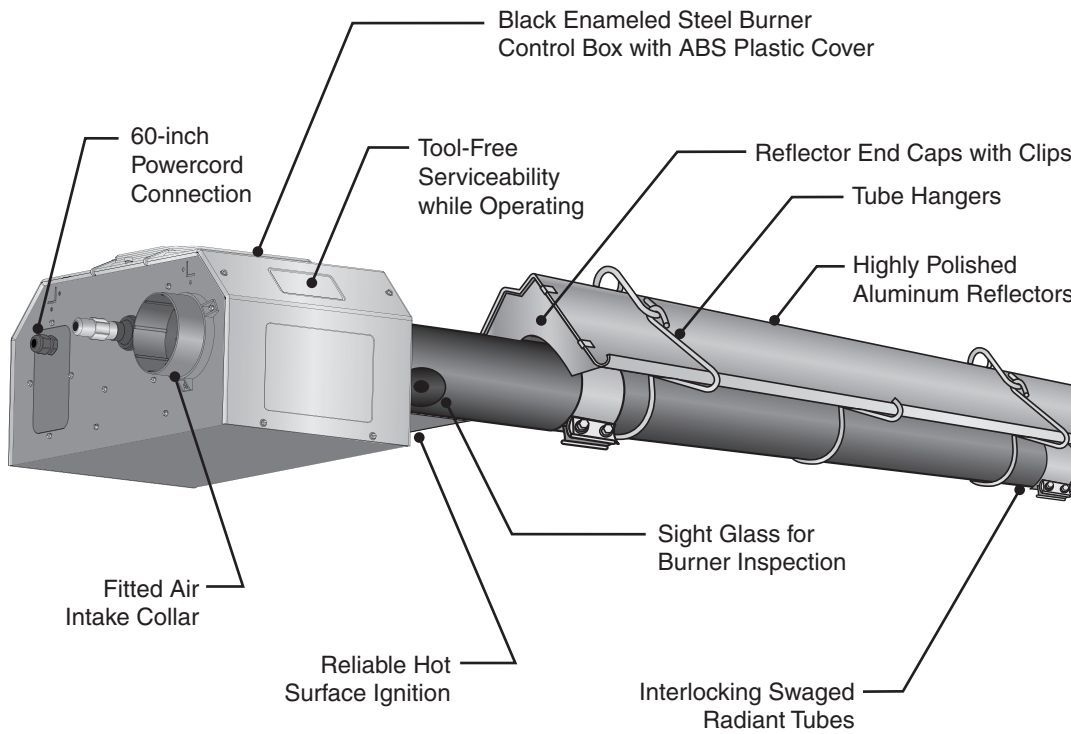

SPECIFIC FEATURES



- Tool-free access to controls.
- Serviceability while unit is operating.
- Separated air and gas burner chamber.
- Symmetrical placement of ignition tube.
- Hinged control compartment provides ease in servicing.
- 3-piece independent compartment cover.
- ABS plastic air intake collar for connection to 4" PVC/DWV pipe.

PRODUCT FEATURES COMPARISON CHART

	HL3	DX3	XTS3	DET3	DES3
Highly Polished Aluminum Reflectors	●	●	●	●	●
Coated Titanium or Aluminized Combustion Chamber	●	●	●	●	●
Coated Aluminized Radiant Tubes	●	●			
Hot Surface Ignition	●	●	●		
Stainless Steel Flexible Gas Connector	●	●	●	●	●
Ball Valve (1/2" Brass) with Pressure Tap Included	●	●			
Two-stage Technology	●			●	
Interlocking Swaged Tubes	●	●	●	●	●
Stainless Steel Models Available*	●	●			
Reflector End Caps Included	●	●	●		
Optional 'U' or 'L' Configurations Available	●	●	●	●	●

* Select upgrades available; full stainless models are available in the HL2 and DX2 Series offering.

DETROIT RADIANT PRODUCTS CO.

21400 Hoover Rd.
Warren, MI 48089-3162

Phone: (586) 756-0950
Toll Free: 1-800-222-1100
Fax: (586) 756-2626
E-mail: sales@drp-co.com
Website: www.reverberray.com

VISIT OUR WEBSITE FOR:

- Product Specs
- Parts Support
- Dealer Locator
- Applications
- C.A.D. Library
- Design Guidelines
- Theory of Infrared
- and More!

HL3 SERIES

SPECIFICATIONS



PRODUCT SPECIFICATIONS

Input Range:	65,000 to 200,000 BTU/h
Lengths:	20-70 Ft.
Gas Type:	Natural or Propane
Combustion Chamber:	Titanium Stabilized or Aluminized Steel
Radiant Tubes:	Coated Aluminized
Certification:	CSA, IAS
Limited Warranty:	1-5-10 (Components-Tubes-Burner)

OPTIONAL EQUIPMENT

U or L Configurations:	Available (RUP, REP)
Stainless Steel Upgrades:	Available (SSTRAO, SSFWAO)
24V Controls:	Standard
Indicator Lights:	Standard
Protective Guards:	Available (PG)
Side Shield Extensions:	Available (SSE)
Outdoor Approval:	Available (OD-KIT)

ELECTRICAL

- 120V, 60Hz, 3-wire.
- 4.8A starting, 1.1A running.

CONTROLS

- Pre & post purge.
- 24V thermostat control.
- Micro-processor circuitry.

TUBE CONSTRUCTION

- As shown to left.
- 4" x 10' 16 ga. construction.
- Labor saving, interlocking swaged tube design.

REFLECTORS

- Highly polished aluminum.
- End caps included.
- 0° – 45° rotatable angle.
- Tension springs.

IGNITION/SENSE

- Hot surface ignition.
- Flame rod sense.
- Self-diagnostic LED

VENTING

- 4" single vent.
- 6" common vent.
(with single thermostat & HLRP)
- SK caps on 200 MBH models.

GAS CONNECTION

- 1/2" NPT ball valve/inlet tap.
- 24" stainless steel flexible connector included.

GAS PRESSURES

- MAN: 3.5" NAT or 10.0" LP
- MIN: 5.0" NAT or 11.0" LP
- MAX: 14.0" NAT or 14.0" LP

COMBUSTION AIR

- Equipped for ducted air intake from roof or sidewall.

KIT CONTENTS

- All hangers & couplers.
- Reflector end caps.
- Turbulator baffles.

AVAILABLE HL3 MODELS & CLEARANCES

MODEL #	GAS*	BTU/H HIGH FIRE	BTU/H LOW FIRE	LENGTH	WEIGHT	MOUNTING HEIGHTS**
HL3-20-65	N or LP	65,000	50,000	21'-9"	120 lbs.	9' to 14'
HL3-20-75^	N or LP	75,000	50,000	21'-9"	120 lbs.	10' to 15'
HL3-30-65	N or LP	65,000	50,000	31'-5"	160 lbs.	10' to 15'
HL3-30-75^	N or LP	75,000	50,000	31'-5"	160 lbs.	11' to 18'
HL3-30-100^	N or LP	100,000	65,000	31'-5"	160 lbs.	12' to 20'
HL3-30-125^	N or LP	120,000	95,000	31'-5"	160 lbs.	13' to 23'
HL3-40-65	N or LP	65,000	50,000	41'-1"	190 lbs.	11' to 18'
HL3-40-75^	N or LP	75,000	50,000	41'-1"	190 lbs.	11' to 18'
HL3-40-100^	N or LP	100,000	65,000	41'-1"	190 lbs.	12' to 20'
HL3-40-125^	N or LP	125,000	95,000	41'-1"	190 lbs.	13' to 23'
HL3-40-150^	N or LP	150,000	100,000	41'-1"	190 lbs.	14' to 25'
HL3-40-175	N or LP	175,000	125,000	41'-1"	190 lbs.	15' to 27'
HL3-50-125^	N or LP	125,000	95,000	50'-9"	235 lbs.	15' to 27'
HL3-50-150^	N or LP	150,000	100,000	50'-9"	235 lbs.	15' to 27'
HL3-50-175	N or LP	175,000	125,000	50'-9"	235 lbs.	16' to 30'
HL3-50-200	N or LP	200,000	145,000	50'-9"	235 lbs.	17' to 35'
HL3-60-150^	N or LP	150,000	100,000	60'-5"	265 lbs.	16' to 30'
HL3-60-175	N or LP	175,000	125,000	60'-5"	265 lbs.	16' to 30'
HL3-60-200	N or LP	200,000	145,000	60'-5"	265 lbs.	17' to 35'
HL3-70-175	N or LP	175,000	125,000	70'-1"	300 lbs.	19' to 42'
HL3-70-200	N or LP	200,000	145,000	70'-1"	300 lbs.	19' to 42'

* Specify natural (N) or propane (LP) gas.

** Factory recommended mounting heights are provided as a guideline. Actual conditions may dictate variations from the above data.

^ Stainless steel tube upgrades available.

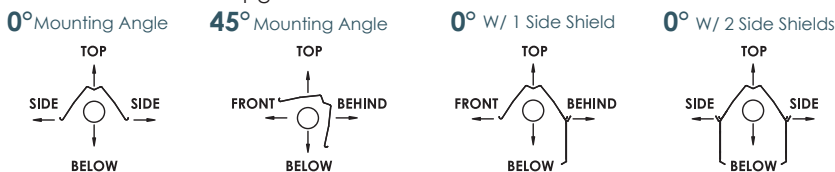

HL3 CLEARANCES TO COMBUSTIBLES (IN.)

MODEL NO.	MOUNTING ANGLE	SIDE		TOP	BELOW
		FRONT	BEHIND		
HL3-(20,30,40)-(65,75)	0°	9	9	6	60
	45°	39	8	10	60
	W/1 side shield	0°	29	8	6
W/2 side shields	0°	9	9	6	60
	20 ft. from burner	0°	7	7	6
HL3-(30,40)-100	0°	14	14	6	66
	45°	39	8	10	66
	W/1 side shield	0°	29	8	6
W/2 side shields	0°	16	16	6	66
	20 ft. from burner	0°	7	7	6
HL3-(30,40,50)-125	0°	20	20	6	76
	45°	58	8	10	76
	W/1 side shield	0°	42	8	6
W/2 side shields	0°	20	20	6	76
	20 ft. from burner	0°	7	7	6
HL3-(40,50,60)-150	0°	24	24	6	81
	45°	58	8	10	81
	W/1 side shield	0°	42	8	6
W/2 side shields	0°	23	23	6	81
	20 ft. from burner	0°	11	11	6
HL3-(40,50,50,70)-175	0°	34	34	6	92
	45°	63	8	10	92
	W/1 side shield	0°	50	8	6
W/2 side shields	0°	30	30	6	92
	20 ft. from burner	0°	11	11	6
HL3-(50,60,70)-200	0°	41	41	6	94
	45°	63	8	10	94
	W/1 side shield	0°	54	8	6
W/2 side shields	0°	30	30	6	94
	20 ft. from burner	0°	11	11	6

Always maintain the published clearances to combustibles.

Clearances published in HL3 Series manual and on warning label supersede data shown on this brochure.

DISTRIBUTED BY:

