

AG-1 Series - 4" Tube Heater Installation, Operation, Maintenance and Parts Manual*

Read carefully before attempting to assemble, install, operate or maintain the product described. Protect yourself and others by observing all safety information. Failure to comply with instructions could result in personal injury and/or property damage! Retain instructions for future reference.

*For complete installation instructions, see Generic IOM this piece was inserted within.

AG-1 Series

Project: _____ Date: _____
 Location: _____
 City: _____ State: _____ Zip: _____
 Contractor: _____
 Engineer: _____
 Local Representative: _____
 Customer Name: _____
 Address: _____
 City: _____ State: _____ Zip: _____
 Serial #: _____ Phone#: _____
 Date of Installation: _____
 Notes: _____

Table of Contents	
	Page
Models	1
Warnings	2
Clearances to Combustibles	2
Product Summary	3
Product Instructions	3
Heater Requirements	4
Theory of Operation	4
Wiring Diagrams	5-7
Flowchart	8-9
Parts Listing	10-11
Series Kit Contents	12

Models

Qty.	Model #	Gas Type (circle one)	BTU's	Applications					Length	Weight	Pcs.	Suggested Height Above Animals	Combustion Chamber	Radiant Emitter Tube	Qty. Alum. Add On	Baffle Pieces	Cert.
				Swine	Arena	Dairy	Poultry	Polebarns & Shops									
	AG-1 20-50	N or LP	50,000	No	Yes	No	Yes	Yes	21'-7"	120 # - 2	6' - 9'	Aluminized	4" Hot Rolled	Qty. 1	5	CSA	
	AG-1 20-60	N or LP	60,000	No	Yes	No	Yes	Yes	21'-7"	120 # - 2	6' - 9'	Aluminized	4" Hot Rolled	Qty. 1	5	CSA	
	AG-1 20-75	N or LP	75,000	No	Yes	Yes	Yes	Yes	21'-7"	120 # - 2	6' - 9'	Aluminized	4" Hot Rolled	Qty. 1	5	CSA	
	AG-1 30-50	N or LP	50,000	No	Yes	No	Yes	Yes	31'-3"	160 # - 2	7' - 10'	Aluminized	4" Hot Rolled	Qty. 2	5	CSA	
	AG-1 30-60	N or LP	60,000	No	Yes	No	Yes	Yes	31'-3"	161 # - 2	7' - 10'	Aluminized	4" Hot Rolled	Qty. 2	5	CSA	
	AG-1 30-75	N or LP	75,000	No	Yes	Yes	Yes	Yes	31'-3"	160 # - 2	7' - 10'	Aluminized	4" Hot Rolled	Qty. 2	5	CSA	
	AG-1 30-100	N or LP	100,000	No	Yes	Yes	Yes	Yes	31'-3"	160 # - 2	8' - 14'	Aluminized	4" Hot Rolled	Qty. 2	6	CSA	
	AG-1 40-60	N or LP	60,000	No	Yes	No	Yes	Yes	40'-11"	190 # - 2	7' - 10'	Aluminized	4" Hot Rolled	Qty. 3	5	CSA	
	AG-1 40-75	N or LP	75,000	No	Yes	Yes	Yes	Yes	40'-11"	190 # - 2	7' - 10'	Aluminized	4" Hot Rolled	Qty. 3	5	CSA	
	AG-1 40-100	N or LP	100,000	No	Yes	Yes	Yes	Yes	40'-11"	190 # - 2	7' - 11'	Aluminized	4" Hot Rolled	Qty. 3	5	CSA	
	AG-1 40-125	N or LP	125,000	No	Yes	Yes	Yes	Yes	40'-11"	190 # - 2	9' - 14'	Aluminized	4" Hot Rolled	Qty. 3	5	CSA	
	AG-1 40-150	N or LP	150,000	No	Yes	Yes	Yes	Yes	40'-11"	190 # - 2	10' - 14'	Titanium	4" Hot Rolled	Qty. 3	5	CSA	
	AG-1 50-100	N or LP	100,000	No	Yes	No	Yes	Yes	50'-7"	235 # - 2	8' - 11'	Aluminized	4" Hot Rolled	Qty. 4	5	CSA	
	AG-1 50-150	N or LP	150,000	No	Yes	No	Yes	Yes	50'-7"	235 # - 2	10' - 14'	Titanium	4" Hot Rolled	Qty. 4	5	CSA	
	AG-1 60-150	N or LP	150,000	No	Yes	No	Yes	Yes	60'-3"	270 # - 3	10' - 14'	Titanium	4" Hot Rolled	Qty. 5	5	CSA	

- AGAO-SS - Upgrade burner box from coated steel to 304 Series Stainless.
- ALUM-AO - Upgrade hot rolled steel radiant tubes to black coated 16ga. aluminized steel for maximum efficiency and longevity.
Highly recommended in any contaminated or moisture laden environment (ex.: poultry applications). See chart above for quantity needed.

Warranty registration options:

1. Register online at www.reverberray.com/warranty
2. Complete the information above and fax to Detroit Radiant Products Co.
3. Complete the information above and mail to Detroit Radiant Products Co.



Printed in U.S.A.
 © Detroit Radiant Products
 21400 Hoover Rd., Warren, MI 48089
 T. (810) 756-0950 F. (810) 756-2626
 Form# LIOAG-1-1M-03/01(ID)



AG-1 Series

⚠ WARNING!

NOT FOR RESIDENTIAL USE!

Do not use in the home, sleeping quarters, attached garages, etc.

⚠ WARNING!

This heater must be installed and serviced by trained gas installation and service personnel only. Read and understand these instructions thoroughly before attempting to install, operate or service this heater. Failure to comply could result in personal injury, asphyxiation, death, fire, and/or property damage. Retain these instructions for future reference.

⚠ WARNING!

This is not an explosion-proof heater. Where there is the possibility of exposure to flammable vapors, consult the local fire marshal, the fire insurance carrier and other authorities for approval of the proposed installation.

⚠ WARNING!

Failure to comply with the stated clearances to combustibles could result in personal injury, death and/or property damage.

⚠ WARNING!

This heater should be installed so that the minimum clearances to vehicles, as marked on the heater, will be maintained. If vehicle lifts are present, ensure that these clearances will be maintained from the highest raised vehicle.

MODEL NO.	MOUNTING ANGLE	SIDE		TOP	BELOW
		FRONT	BEHIND		
		AG-1 (20,30)-50 [N,P]	0°		
	45°	39	8	10	47
W/1 side shield	0°	29	8	6	47
W/2 side shields	0°	9	9	6	47
20 ft from burner	0°	7	7	6	30
AG-1 (20,30,40)-60 [N,P]	0°	9	9	6	47
	45°	39	8	10	47
W/1 side shield	0°	29	8	6	47
W/2 side shields	0°	9	9	6	47
20 ft from burner	0°	7	7	6	30
AG-1 (20,30,40)-75 [N,P]	0°	9	9	6	60
	45°	39	8	10	60
W/1 side shield	0°	29	8	6	60
W/2 side shields	0°	9	9	6	60
20 ft from burner	0°	7	7	6	30
AG-1 (30,40,50)-100 [N,P]	0°	14	14	6	66
	45°	39	8	10	66
W/1 side shield	0°	29	8	6	66
W/2 side shields	0°	16	16	6	66
20 ft from burner	0°	7	7	6	30
AG-1 40-125 [N,P]	0°	20	20	6	76
	45°	58	8	10	76
W/1 side shield	0°	42	8	6	76
W/2 side shields	0°	20	20	6	76
20 ft from burner	0°	7	7	6	30
AG-1 (40,50,60)-150 [N,P]	0°	24	24	6	81
	45°	58	8	10	81
W/1 side shield	0°	42	8	6	81
W/2 side shields	0°	23	23	6	81
20 ft from burner	0°	11	11	6	44

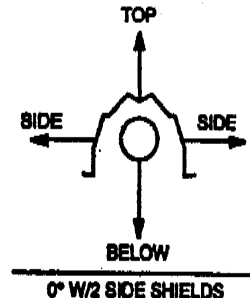
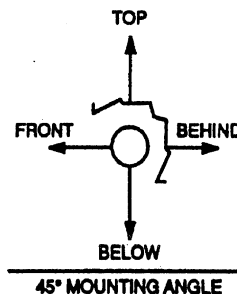
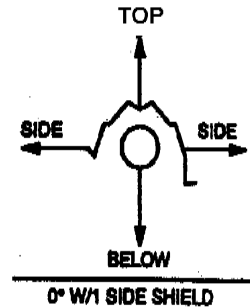
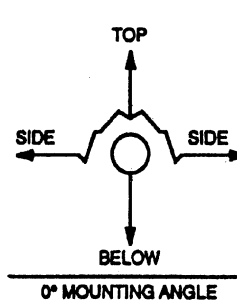

AG-1 Series Mechanical Instructions

This supplement is designed to address the specifics of the AG-1 Series. Also see the generic IOM supplied with model.

Product Summary

AG-1 Series heaters are available from 20 to 60 foot, 50,000 to 150,000 BTU's, natural or LP gas. AG-1 Series are positive pressure, single stage heaters and feature uncoated hot rolled steel for it's radiant pipes.

Operational Features

Outside air for combustion is required in all agricultural applications. Place air inlet in a non-contaminated area, away from any steam or moisture sources.

Product Installation

Aluminized (50-125 MBTU/H)	Hot rolled steel				The AG-1 <u>ALWAYS</u> has a 4" black coated combustion chamber (identified by an orange sticker) and 4" uncoated hot rolled steel heat exchangers, following the combustion chamber and every tube there after. Tube packages with the ALUM-AO upgrade will have 4" black coated aluminized heat exchangers replacing the uncoated hot rolled steel.
Aluminized (50-125 MBTU/H)	Hot rolled steel	Hot rolled steel			
Aluminized or Titanium (50-125 MBTU/H)	Hot rolled steel	Hot rolled steel	Hot rolled steel		
Aluminized or Titanium (50-125 MBTU/H)	Hot rolled steel	Hot rolled steel	Hot rolled steel	Hot rolled steel	

Combustion Air

The combustion air intake collar is also a factory-preset air orifice. Non-contaminated air for combustion must be ducted to the heater in all agricultural applications. Do not take combustion air from attic. Locate intake away from any steam source. Use caution when placing intake above curtain walls, as they leak. See adjacent figure. Use light gauge, 4 inch PVC air intake material from curtain sidewall to heater. Do not exceed 25 feet. With elbow, drop below curtain top, one foot in length. Cap with 1/4 inch birdscreen.

Optional Side Shields

Optional Food Line Shield Installation (FLS)

1. Install optional FLS where needed to protect feeder lines that are within the clearance to combustibles zone.
2. It may be necessary to directly shield plastic tubing if it is located within the specified clearance to combustibles zone.



AG-1 Series

Electrical Requirements

- ◆ 120 Volt - 60 HZ
- ◆ Starting Current 4.8 Amps
- ◆ Running Current 1.1 Amps
- ◆ 24V Control Voltage

Gas Requirements

- ◆ Manifold Pressure
 - Nat. 3.5" • LP. 10.0"
- ◆ Minimum Inlet Pressure
 - Nat. 5.0" • LP. 11.0"
- ◆ Maximum Inlet
 - Nat. 14.0" • LP. 14.0"

Ventilation Requirements

- ◆ In agricultural applications, these heaters are generally unvented.
- ◆ Consult the generic supplement for venting instructions.
- ◆ For unvented operation, there must be a positive air displacement of at least 4.0 CFM per 1000 BTU/H for natural gas or 4.5 CFM per 1000 BTU/H for LP gas. WVE-4 termination cap must also be used.

Theory of Operation

Starting Circuit

When voltage is applied to L1 and L2 (see diagram on right), a circuit is completed from L1 via the blower motor to L2. The blower fan is mounted in the control box and rated to supply sufficient air for combustion.

Air pressure generated by the blower will cause the differential pressure switch No. 1 to close. Another circuit is completed from L1 to the hot surface ignition control and back to L2. There is a five second delay, then the glo-bar is powered. After the glo-bar has been powered for 45 seconds, the control causes the gas valve to open and initiates the ignition trial.

Power to the glo-bar is shut off during the last two or three seconds of the ignition trial.

Running Circuit

After ignition, the flame rod monitors the flame. As long as a flame is present, the valve is held open. If the flame is lost, the control acts to close the valve within one second, and a new trial sequence identical to that at start-up is initiated. If proof of flame is not established within 8.5 seconds, the unit will lock out. If lockout occurs, the control can be reset by briefly interrupting the power source.

Internal Wiring Diagrams

LADDER DIAGRAM - MARK17DU-117 SINGLE PRESSURE SWITCH

*INTERNAL RELAY

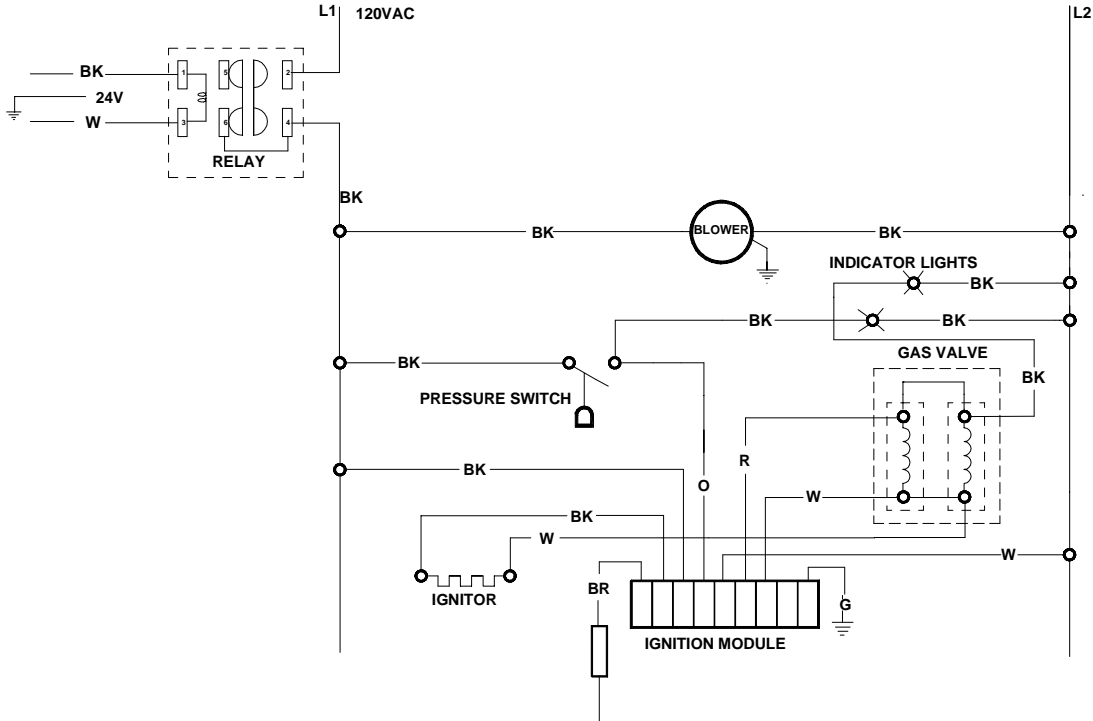

IF ANY OF THE ORIGINAL WIRE AS SUPPLIED WITH THE APPLIANCE MUST BE REPLACED, IT MUST BE REPLACED WITH WIRING MATERIAL HAVING A TEMPERATURE RATING OF AT LEAST 105 C.

BLOCK DIAGRAM - MARK17DU-117 SINGLE PRESSURE SWITCH

*INTERNAL RELAY

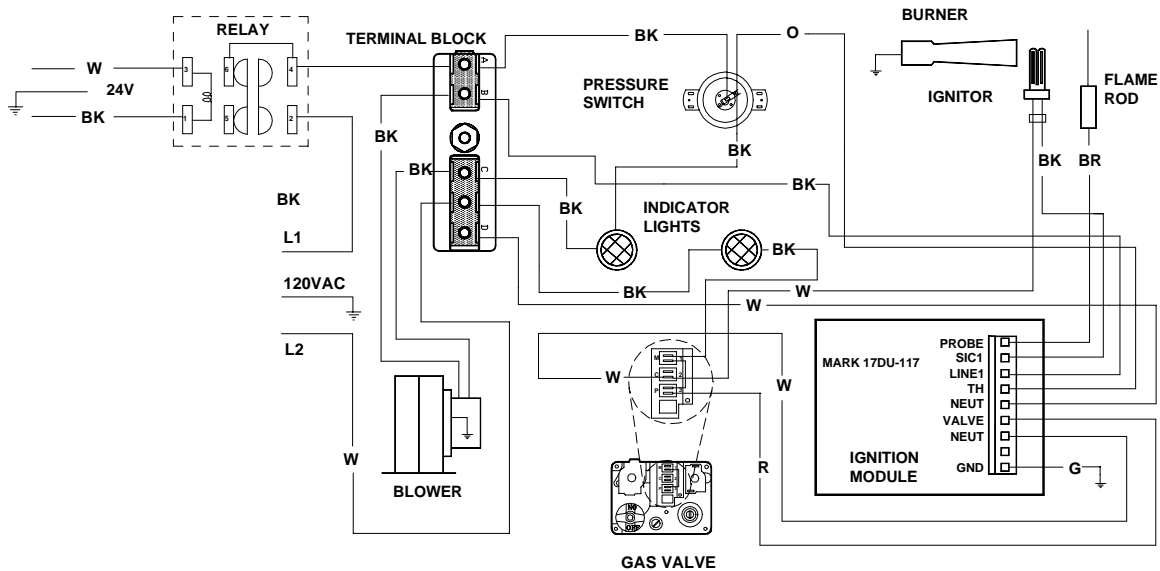

AG-1 Series

Field Wiring Diagrams

AG-1 FIELD WIRING WITH INTERNAL RELAY

THE INTERNAL RELAY ALLOWS FOR LOW VOLTAGE T-STAT OPERATION OF LINE VOLTAGE HEATERS

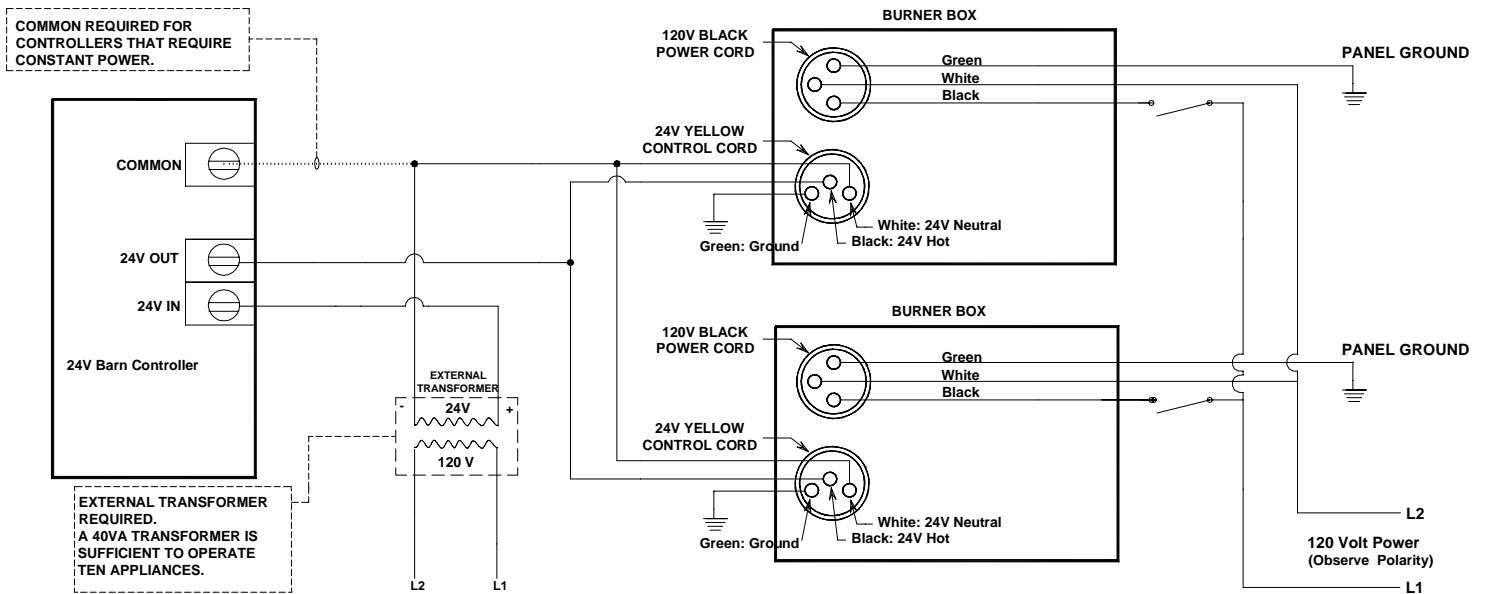

Alternative Wiring Diagrams

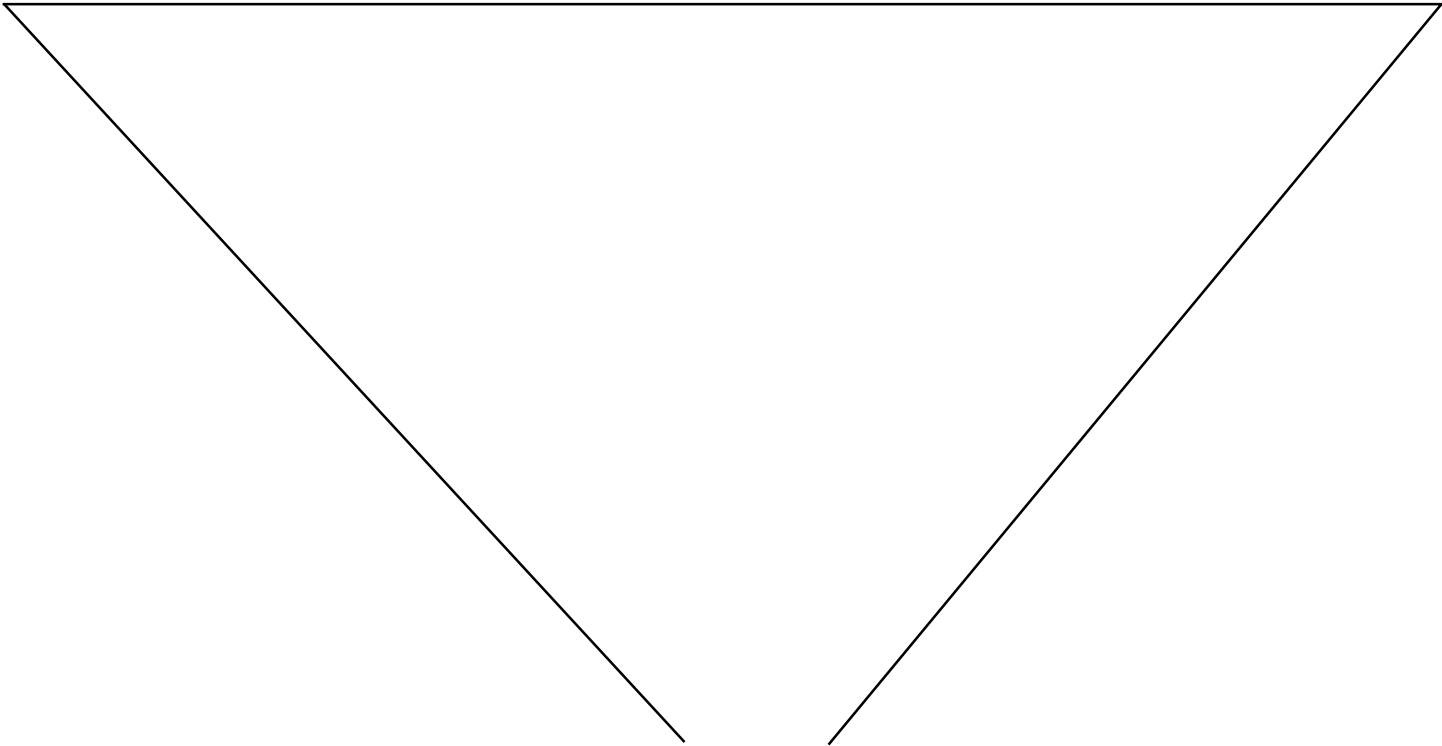

THIS PAGE INTENTIONALLY LEFT BLANK.
THERE ARE NO ALTERNATIVE WIRING DIAGRAMS FOR THE AG-1 SERIES

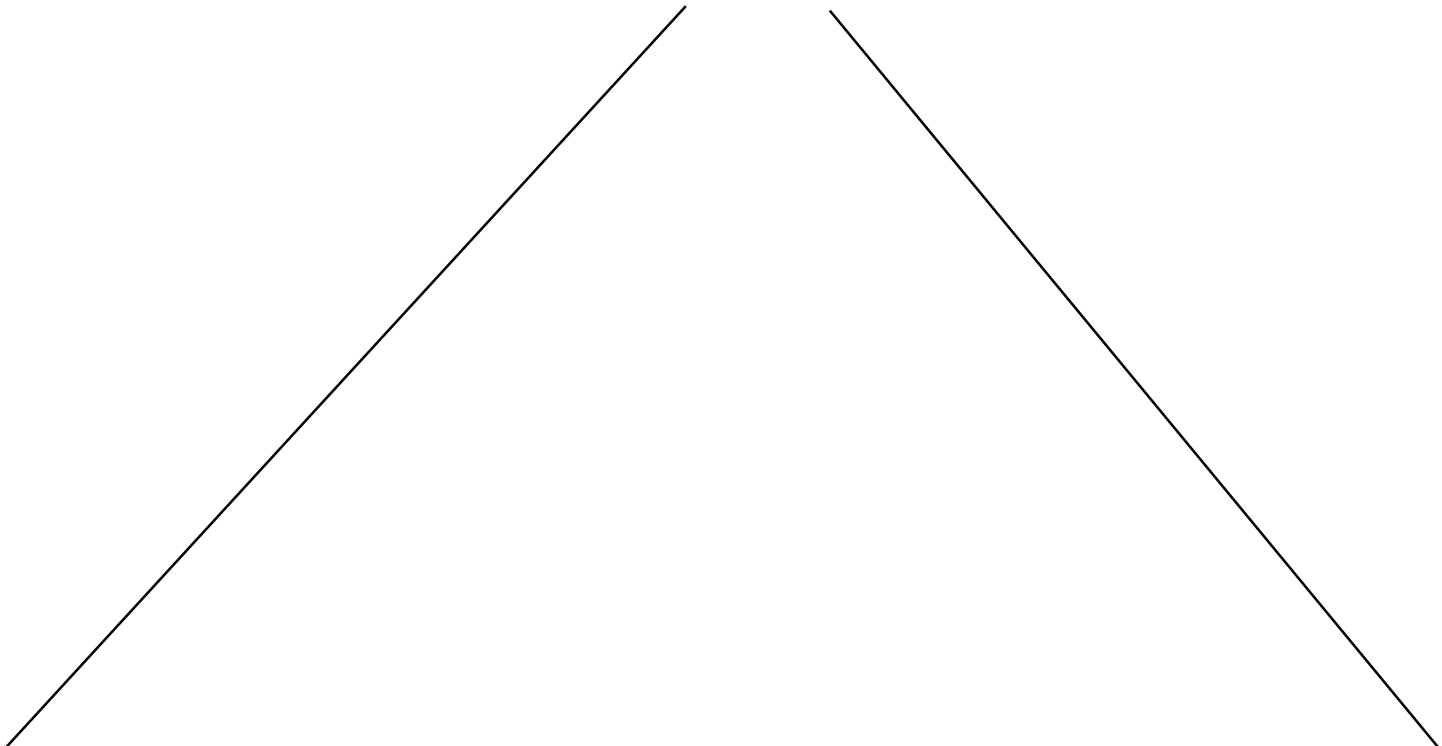

AG-1 Troubleshooting Flow Chart

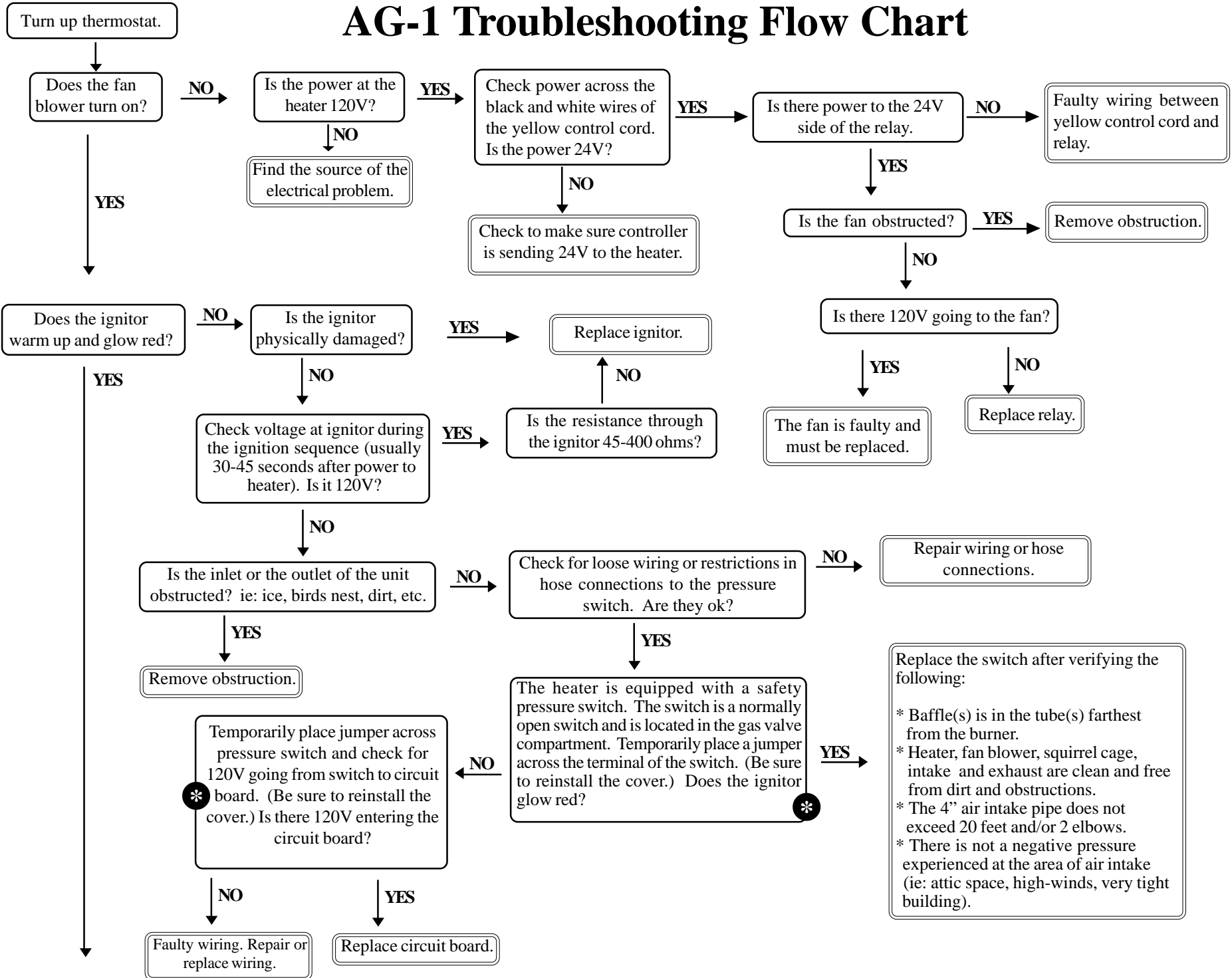

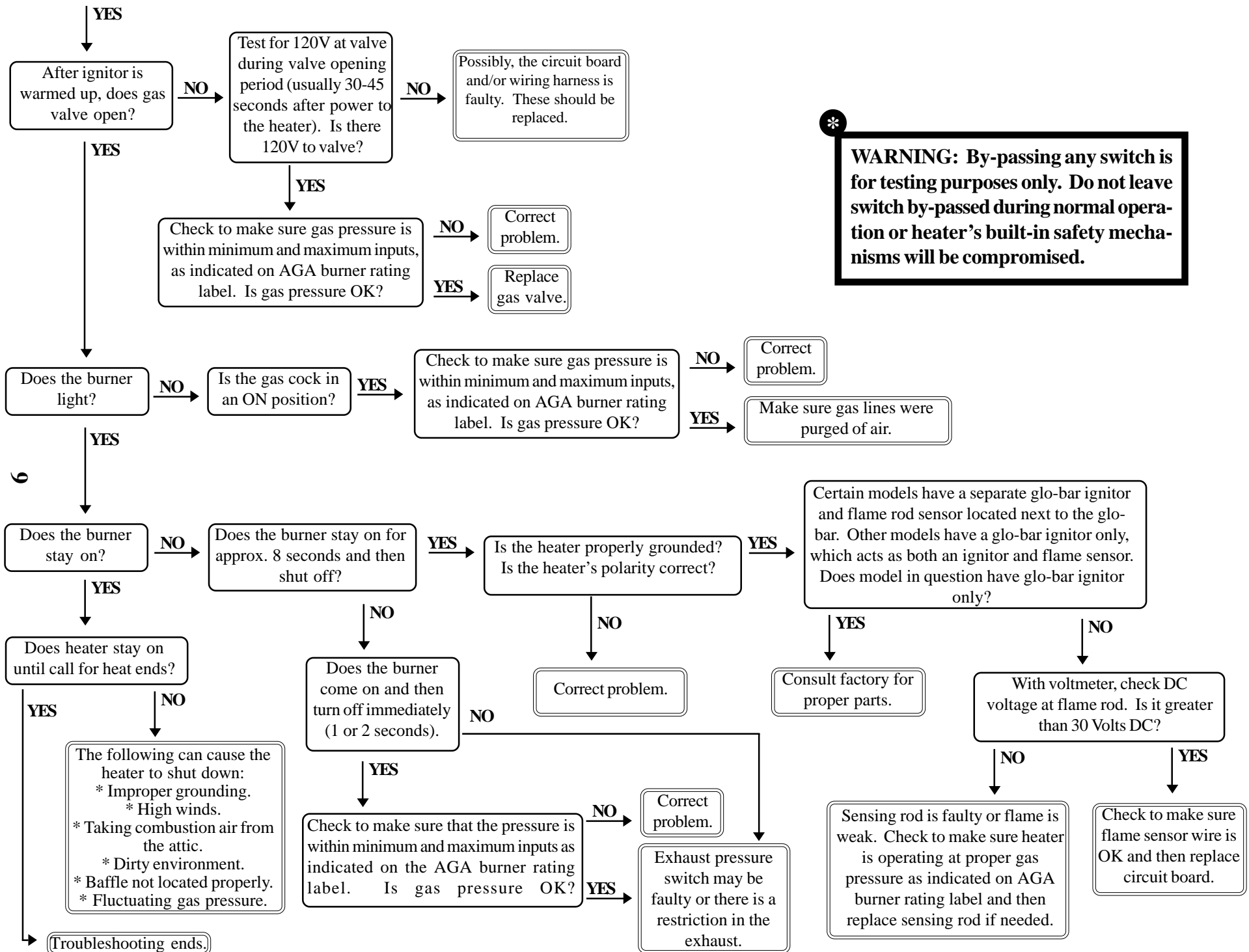

*** WARNING: By-passing any switch is for testing purposes only. Do not leave switch by-passed during normal operation or heater's built-in safety mechanisms will be compromised.**

AG-1 Series

Parts Breakdown

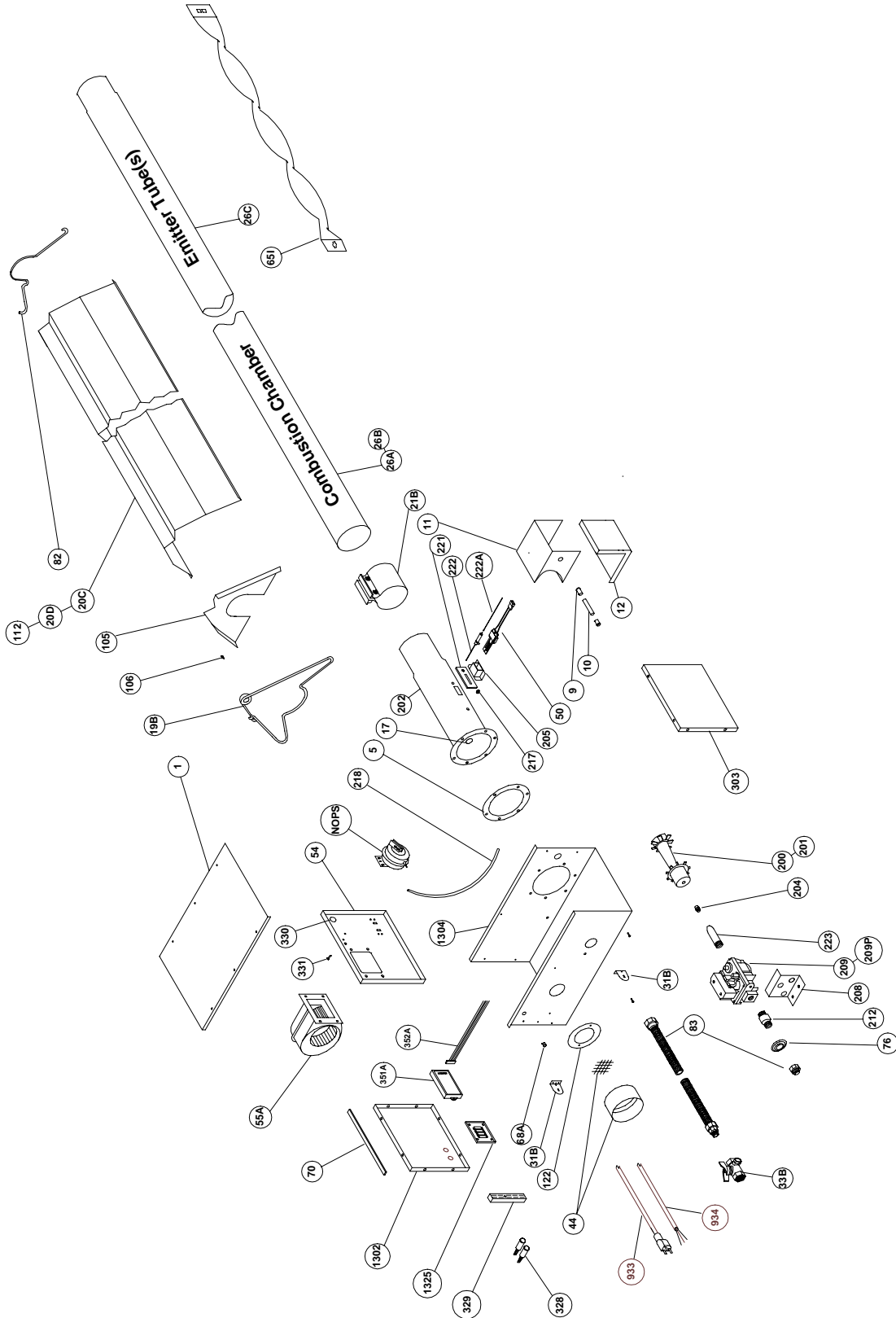



AG-1 SERIES PARTS LISTING

TP#	ITEM	TP#	ITEM
TP-1	CONTROL BOX COVER	TP-201	BURNER (125 TO 150 MBTU/H)
TP-5	FLANGE GASKET	TP-202	16" BURNER TUBE WITH FLANGE
TP-9	CONDUIT COUPLING	TP-204	GAS ORIFICE - CONSULT FACTORY
TP-10	CONDUIT 4" X 1/2"	TP-205	GLO-BAR HOLDER
TP-11	GLO-BAR IGNITOR BOX	TP-208	"Z" MOUNTING BRACKET
TP-12	GLO-BAR IGNITOR BOX COVER	TP-209	36E36A-246 GAS VALVE - NAT GAS ASSY
TP-17	SIGHT GLASS KIT	TP-209P	36E36A-240 GAS VALVE - LP GAS ASSY
TP-19B	WIRE HANGER W/ SPRING CLIP	TP-212	1/2" X 3" PIPE NIPPLE
TP-20C	120" ALUMINUM REFLECTOR	TP-217	PRESSURE BARB FITTING
TP-20D	120" STAINLESS STEEL REFLECTOR	TP-218	EXHAUST PRESSURE TUBE (VINYL)
TP-21B	TUBE CLAMP	TP-221	GLO-BAR HOLDER GASKET
TP-26A	10 FT. ALUMINIZED COMBUSTION/RADIANT TUBE	TP-222	FLAME ROD
TP-26B	10 FT. TITANIUM COMBUSTION TUBE	TP-222A	FLAME ROD WIRE
TP-26C	UNCOATED HOT ROLLED STEEL RADIANT TUBE	TP-223	GAS MANIFOLD
TP-31B	CONTROL BOX BRACKET	TP-303	RIGHT END PANELS - NO HOLES
TP-33B	1/2" GAS COCK	TP-328	120V INDICATOR LIGHTS
TP-44	AIR ORIFICE W/SCREEN - CONSULT FACTORY	TP-329	1/4" NEUTRAL TERMINAL BLOCK
TP-50	GLO-BAR IGNITOR	TP-330	DIVIDER GROMMET
TP-54	DIVIDER PANEL W/ P.S. MOUNTING TABS	TP-331	GREEN SELF TAP GROUND SCREW
TP-55A	FAN BLOWER	TP-351A	MARK 17DU-117 POTTED CIRCUIT BOARD
TP-65I	INTERLOCKING 33" BAFFLE SECTION	TP-352A	LONG WIRING HARNESS FOR 17DU-117
TP-68A	STRAIN RELIEF BUSHING	TP-933	6' BLACK 120V PLUG
TP-70	CONTROL BOX COVER GASKET (PER FOOT**)	TP-934	YELLOW 24V CONTROL WIRE
TP-76	RUBBER GROMMET	TP-1302	LEFT END PANEL W/ LIGHT HOLES
TP-82	REFLECTOR CENTER SUPPORT	TP-1304	CONTROL BOX
TP-83	STAINLESS STEEL FLEX CONNECTOR	TP-1325	RELAY BOARD (24V SWITCHING 120V)
TP-105	REFLECTOR END CAP	TP-NOPS	NORMALLY OPEN DIFFERENTIAL SWITCH
TP-106	REFLECTOR CLIP	(TP-61B)	N.O. Differential Pressure Switch (65 TO 75MBTU/H)
TP-112	5' REFLECTOR	(TP-61E)	N.O. Differential Pressure Switch (100 TO 125MBTU/H)
TP-122	GASKET FOR AIR ORIFICE & AIR COLLAR	(TP-61D)	N.O. Differential Pressure Switch (150MBTU/H)
TP-200A	BURNER (50 TO 100 MBTU/H)		







** 6' TOTAL NEEDED TO COVER OUTER EDGES OF A BURNER BOX.



Kit Contents & Product Features

Kit contents for the AG-1 Series are shown below. Reference the proper column for your particular models length.

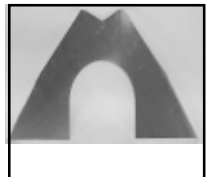
FILLED BY:		AG-1 SERIES KIT CONTENTS				
TP#	DESCRIPTION	20 FOOT	30 FOOT	40 FOOT	50 FOOT	60 FOOT
TP-19B	4" Hangers	3	4	5	6	7
TP-21B	4" Tube Clamps	2	3	4	5*	6*
TP-33B	1/2" Gas Cock	1	1	1	1	1
TP-82	4" Refl. Cntr. Sprt.	1	1	1	1	1
TP-83	24" SS Flex Line	1	1	1	1	1
TP-105	Refl. End caps	2	2	2	2	2
TP-106	Refl. End cap Clips	8	8	8	8	8
IOM	Install / Op Manual	1	1	1	1	1

						
4" Hanger TP-19B	4" Butt Clamp TP-21B	Gas Cock 1/2" TP-33B	Bag of Reflector End Cap Clips. TP-106	24" SS Flex Connect TP-83	Reflector End Caps TP-105	Generic IOM LIOM-Tube AND Series Insert LIOM-AG-1

Product Features

APPROVALS

- IAS, AGA.
- Indoor approval.
- Commercial approval.

BURNERSIGHT GLASS

- For burner inspection.

COMBUSTION AIR INLET & VENT

- 4" Male duct.

WATERPROOFED CONTROL BOX

- Outside air collar (4") attached.
- Totally enclosed components.

CONTROLS

- 100% safety shut off.
- Moisture and corrosion resistant ignition module.
- Differential pressure switch.
- Stainless steel flame swirl burner.
- Silicon carbide hot surface igniter.
- Flame rod sensing.
- Pre-purge controls.

GAS CONNECTION

- 1/2" gas cock attached.
- 7/8" flare-2' S.S. flex included.

EMMITER & COMBUSTION TUBES

- 16ga. 4" O.D. hot rolled steel.
- Slip fit connection.
- Aluminized combustion chamber (50-125 MBTU/H models).
- Titanium combustion chamber (150 MBTU/H models).

WARRANTY

- 1 year - Burner box components.
- 3 years - Combustion and radiant tubes.
- 5 years - Burner.

OTHER

- One reflector center support per heater.
- Turbulator baffle included.
- Made in U.S.A.