

AG-2 Series - 4" Tube Heater Installation, Operation, Maintenance and Parts Manual*

Read carefully before attempting to assemble, install, operate or maintain the product described. Protect yourself and others by observing all safety information. Failure to comply with instructions could result in personal injury and/or property damage! Retain instructions for future reference.

*For complete installation instructions, see Generic IOM this piece was accompanied by.

AG-2 Series

Project: _____ Date: _____
 Location: _____
 City: _____ State: _____ Zip: _____
 Contractor: _____
 Engineer: _____
 Local Representative: _____
 Customer Name: _____
 Address: _____
 City: _____ State: _____ Zip: _____
 Serial #: _____ Phone#: _____
 Date of Installation: _____
 Notes: _____

Table of Contents	
	Page
Models	1
Warnings	2
Clearances to Combustibles	2
Product Summary	3
Product Instructions	3
Heater Requirements	4
Theory of Operation	4
Wiring Diagrams	5-7
Flowchart	8-9
Parts Listing	10-11
Series Kit Contents	12

Models

Qty.	Model #	Gas Type (circle one)	MBTU's	Applications					Length	Weight	Pcs.	Suggested Height Above Animals	Combustion Chamber	Radiant Emitter Tube	Qty. Alum. Add On	Baffle Pieces	Cert.
				Swine	Arena	Dairy	Poultry	Polebarns & Shops									
	AG-2 20-65	N or LP	65/50	No	Yes	No	Yes	Yes	21'-7"	120 # - 2		6' - 9'	Aluminized	4" Hot Rolled	Qty. 1	5	CSA
	AG-2 20-75	N or LP	75/50	No	Yes	Yes	Yes	Yes	21'-7"	120 # - 2		7' - 10'	Aluminized	4" Hot Rolled	Qty. 1	5	CSA
	AG-2 30-65	N or LP	65/50	No	Yes	No	Yes	Yes	31'-3"	160 # - 2		6' - 9'	Aluminized	4" Hot Rolled	Qty. 2	5	CSA
	AG-2 30-75	N or LP	75/50	No	Yes	Yes	Yes	Yes	31'-3"	160 # - 2		7' - 10'	Aluminized	4" Hot Rolled	Qty. 2	5	CSA
	AG-2 30-100	N or LP	100/65	No	Yes	Yes	Yes	Yes	31'-3"	160 # - 2		8' - 14'	Aluminized	4" Hot Rolled	Qty. 2	6	CSA
	AG-2 40-65	N or LP	65/50	No	Yes	No	Yes	Yes	40'-11"	190 # - 2		6' - 9'	Aluminized	4" Hot Rolled	Qty. 3	5	CSA
	AG-2 40-75	N or LP	75/50	No	Yes	Yes	Yes	Yes	40'-11"	190 # - 2		7' - 10'	Aluminized	4" Hot Rolled	Qty. 3	5	CSA
	AG-2 40-100	N or LP	100/65	No	Yes	Yes	Yes	Yes	40'-11"	190 # - 2		7' - 11'	Aluminized	4" Hot Rolled	Qty. 3	5	CSA
	AG-2 40-125	N or LP	125/95	No	Yes	Yes	Yes	Yes	40'-11"	190 # - 2		9' - 14'	Aluminized	4" Hot Rolled	Qty. 3	5	CSA
	AG-2 40-150	N or LP	150/100	No	Yes	Yes	Yes	Yes	40'-11"	190 # - 2		10' - 14'	Titanium	4" Hot Rolled	Qty. 3	5	CSA
	AG-2 50-100	N or LP	100/65	No	Yes	No	Yes	Yes	50'-7"	235 # - 2		8' - 11'	Aluminized	4" Hot Rolled	Qty. 4	5	CSA
	AG-2 50-150	N or LP	150/100	No	Yes	No	Yes	Yes	50'-7"	235 # - 2		10' - 14'	Titanium	4" Hot Rolled	Qty. 4	5	CSA
	AG-2 60-150	N or LP	150/100	No	Yes	No	Yes	Yes	60'-3"	270 # - 3		10' - 14'	Titanium	4" Hot Rolled	Qty. 5	5	CSA

- AGAO-SS - Upgrade burner box from coated steel to 304 Series Stainless.
- ALUM-AO - Upgrade hot rolled steel radiant tubes to black coated 16ga. aluminized steel for maximum efficiency and longevity.
Highly recommended in any contaminated or moisture laden environment (ex.: poultry applications). See chart above for quantity needed.

Warranty registration options:

1. Register online at www.reverberay.com/warranty
2. Complete the information above and fax to Detroit Radiant Products Co.
3. Complete the information above and mail to Detroit Radiant Products Co.



AG-2 Series

⚠ WARNING!

NOT FOR RESIDENTIAL USE!

Do not use in the home, sleeping quarters, attached garages, etc.

⚠ WARNING!

This heater must be installed and serviced by trained gas installation and service personnel only. Read and understand these instructions thoroughly before attempting to install, operate or service this heater. Failure to comply could result in personal injury, asphyxiation, death, fire, and/or property damage. Retain these instructions for future reference.

⚠ WARNING!

This is not an explosion-proof heater. Where there is the possibility of exposure to flammable vapors, consult the local fire marshal, the fire insurance carrier and other authorities for approval of the proposed installation.

⚠ WARNING!

Failure to comply with the stated clearances to combustibles could result in personal injury, death and/or property damage.

⚠ WARNING!

This heater should be installed so that the minimum clearances to vehicles, as marked on the heater, will be maintained. If vehicle lifts are present, ensure that these clearances will be maintained from the highest raised vehicle.

CLEARANCES TO COMBUSTIBLES (IN.)

MODEL NO.	MOUNTING ANGLE	SIDE		TOP	BELOW	
		FRONT	BELOW			
AG-2 (20,30,40) - 65 [N,P]	0°	9	9	6	60	
	45°	39	8	10	60	
	W/1 side shield	0°	29	8	6	60
	W/2 side shields	0°	9	9	6	60
	20 ft from burner	0°	7	7	6	30
AG-2 (20,30,40) - 75 [N,P]	0°	9	9	6	60	
	45°	39	8	10	60	
	W/1 side shield	0°	29	8	6	60
	W/2 side shields	0°	9	9	6	60
	20 ft from burner	0°	7	7	6	30
AG-2 (20,30,40,50) - 100 [N,P]	0°	14	14	6	66	
	45°	39	8	10	66	
	W/1 side shield	0°	29	8	6	66
	W/2 side shields	0°	16	16	6	66
	20 ft from burner	0°	7	7	6	30
AG-2 (30,40,50,60)-125 [N,P]	0°	20	20	6	76	
	45°	58	8	10	76	
	W/1 side shield	0°	42	8	6	76
	W/2 side shields	0°	20	20	6	76
	20 ft from burner	0°	7	7	6	30
AG-2 (40,50,60) - 150 [N,P]	0°	24	24	6	81	
	45°	58	8	10	81	
	W/1 side shield	0°	42	8	6	81
	W/2 side shields	0°	23	23	6	81
	20 ft from burner	0°	11	11	6	44

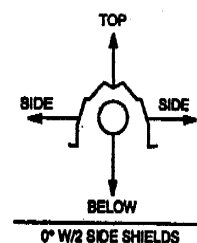
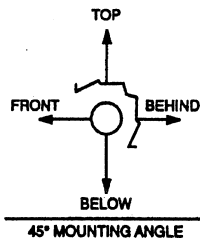
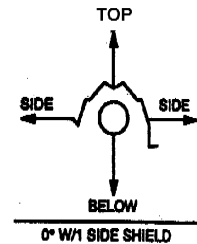
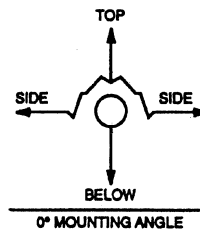

AG-2 Series Mechanical Instructions

This supplement is designed to address the specifics of the AG-2 Series - see page 12 for product features.

Product Summary

AG-2 Series heaters are available from 20 to 60 foot, 65,000 to 150,000 BTU's, natural or LP gas. AG-2 Series are positive pressure, two-stage heaters and feature hot rolled steel for it's radiant pipes.

Be sure to identify the aluminized (65-125 MBTU/H) or titanium (150 MBTU/H) combustion chamber and place as the first tube section.

Product Installation

Aluminized (65-125 MBTU/H)	Hot rolled steel			
Aluminized (65-125 MBTU/H)	Hot rolled steel	Hot rolled steel		
Aluminized or Titanium (65-125 MBTU/H) (150 MBTU/H)	Hot rolled steel	Hot rolled steel	Hot rolled steel	
Aluminized or Titanium (65-125 MBTU/H) (150 MBTU/H)	Hot rolled steel	Hot rolled steel	Hot rolled steel	Hot rolled steel

The AG-2 **ALWAYS** has a 4" black coated combustion chamber (identified by an orange sticker) and 4" uncoated hot rolled steel heat exchangers, following the combustion chamber and every tube there after. Tube packages with the ALUM-AO upgrade will have 4" black coated aluminized heat exchangers replacing the uncoated hot rolled steel.

Combustion Air

The combustion air intake collar is also a factory-preset air orifice. Non-contaminated air for combustion must be ducted to the heater in all agricultural applications. Do not take combustion air from attic. Locate intake away from any steam source. Use caution when placing intake above curtain walls, as they leak. See adjacent figure. Use light gauge, 4 inch PVC air intake material from curtain sidewall to heater. Do not exceed 25 feet. With elbow, drop below curtain top, one foot in length. Cap with 1/4 inch birdscreen.

Optional Side Shields

Optional Food Line Shield Installation (FLS)

1. Install optional FLS where needed to protect feeder lines that are within the clearance to combustible zone.
2. It may be necessary to directly shield plastic tubing if it is located within the specified clearance to combustibles zone.



AG-2 Series

Electrical Requirements

- ◆ 120 Volt - 60 Hz GRD, 3-wire.
- ◆ 24V thermostat connection.
- ◆ Starting current 4.8 amps
- ◆ Running current 1.1 amps

Gas Requirements

- ◆ Manifold Pressure
 - Nat. 3.5" • LP. 10.0"
- ◆ Minimum Inlet Pressure
 - Nat. 5.0" • LP. 11.0"
- ◆ Maximum Inlet
 - Nat. 14.0" • LP. 14.0"

Ventilation Requirements

- ◆ In agricultural applications, these heaters are generally unvented.
- ◆ Consult the generic supplement for venting instructions.
- ◆ For unvented operation, there must be a positive air displacement of at least 4.0 CFM per 1000 BTU/H for natural gas or 4.5 CFM per 1000 BTU/H for LP gas. WVE-4 termination cap must also be used.

Theory of Operation

Standby:

The Micro 60U24 control continually checks for internal faults, safety circuit integrity, and relay contact positioning.

Starting Circuit:

Upon a call for heat, the control will verify that the differential pressure switch is in the proper position. The fan relay energizes the fan, an operational static pressure is achieved and the normally open burner pressure switch will close, initiating the ignition sequence. The glow-bar is powered and after 45 seconds the main gas valve opens. If flame is not established the heater will attempt to re-ignite for a total of three trials for ignition and then proceed to lockout.

First Stage Running Circuit:

After ignition the flame-rod monitors the main burner flame. If flame is lost, the control acts to close the gas valve within one second and a new trial sequence, identical to the start up sequence, is initiated. If proof is not established within 8.5 seconds, the unit will retry 2 additional ignition sequences and then proceed to hard lock-out. The control can be reset by interrupting the power source or at the thermostat.

Second Stage Running Circuit:

Stage two on the gas valve is powered directly from the second stage of the thermostat. In order for the second stage to flow the higher output, the first stage has to be energized as well. The thermostat will determine which stage is required to maintain the desired comfort level.

Shut Down:

When the thermostat is satisfied the fan will enter into a 2 minute post-purge cycle.

Soft Lockout:

In the event of an external interruption (wind, gas, etc.) the heater will go into a "soft-lockout" feature. In this mode the heater will attempt a normal start-up after approximately 30 seconds. In the event of continued problems, the heater will go into a hard lock-out mode.

Lockout Codes:

In event of a component failure, a red LED diagnostic light located on the burner box end panel will flash a code identifying the fault. Lockout codes are summarized in the table below. Some fault codes have a time delay before the LED will flash. Refer to the FAULT CODE DELAY on the chart to see the approximate time delay.

LED CODE	FAULT STATUS	FAULT CODE DELAY
Initial flash on power up, then steady off	Normal operation	Immediate
Steady on	Module failure / Internal fault	Immediate
1 flash	Ignition failure	30-32 minutes
2 flashes	APS 1 failure	10-12 minutes
3 flashes	ASP 2 failure	20-22 minutes
4 flashes	Solenoid valve fault / Leaky valve / Flame amplifier fault	Immediate
No flash on 117V start up	Transformer fault	Immediate

Note: Hard lockout LED code will appear upon completion of the soft lockout sequence of operation.

Internal Wiring Diagrams

MICRO 60U-24 Single Pressure Switch

WITH HLRB RELAY BOARD

MICRO 60U-24 LADDER DIAGRAM - WITH RELAY BOARD

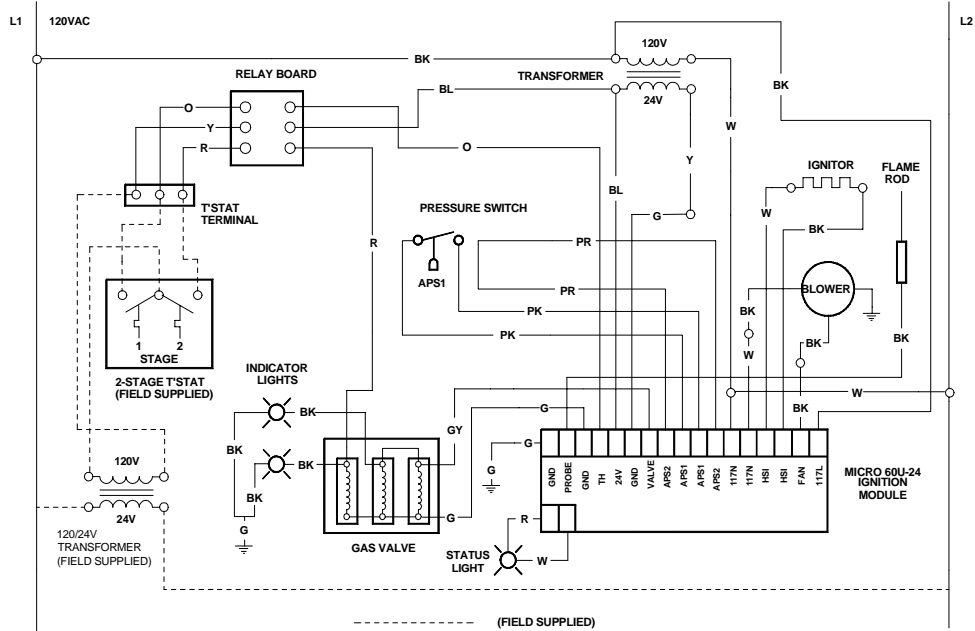

MICRO 60U-24 BLOCK DIAGRAM - WITH RELAY BOARD

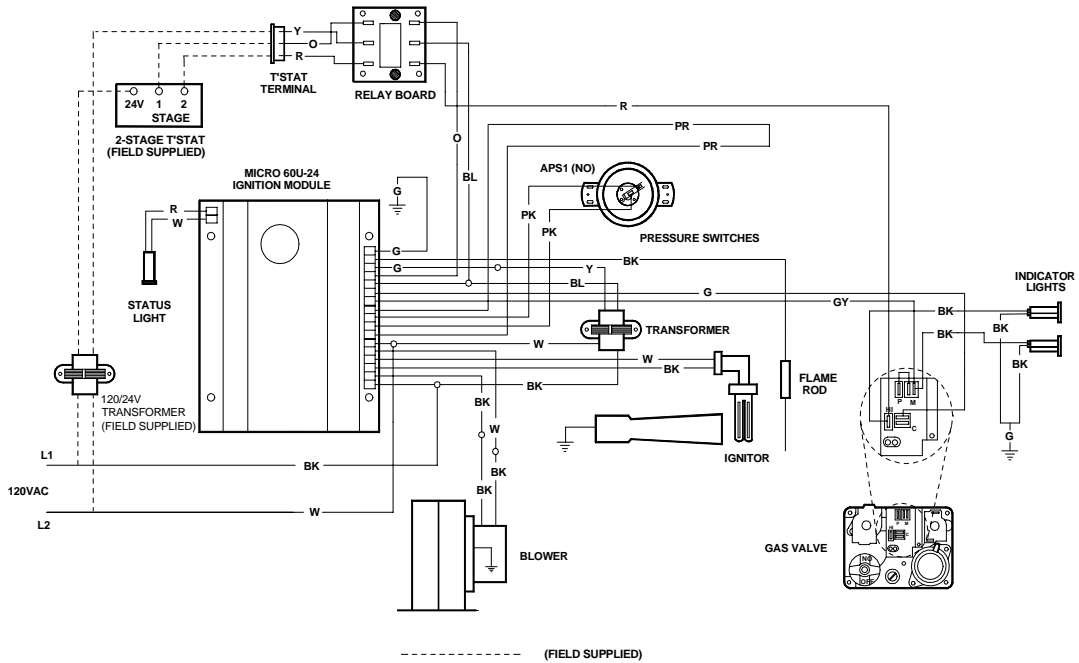

AG-2 Series

Field Wiring Diagrams

AG-2 FIELD WIRING WITH INTERNAL RELAY

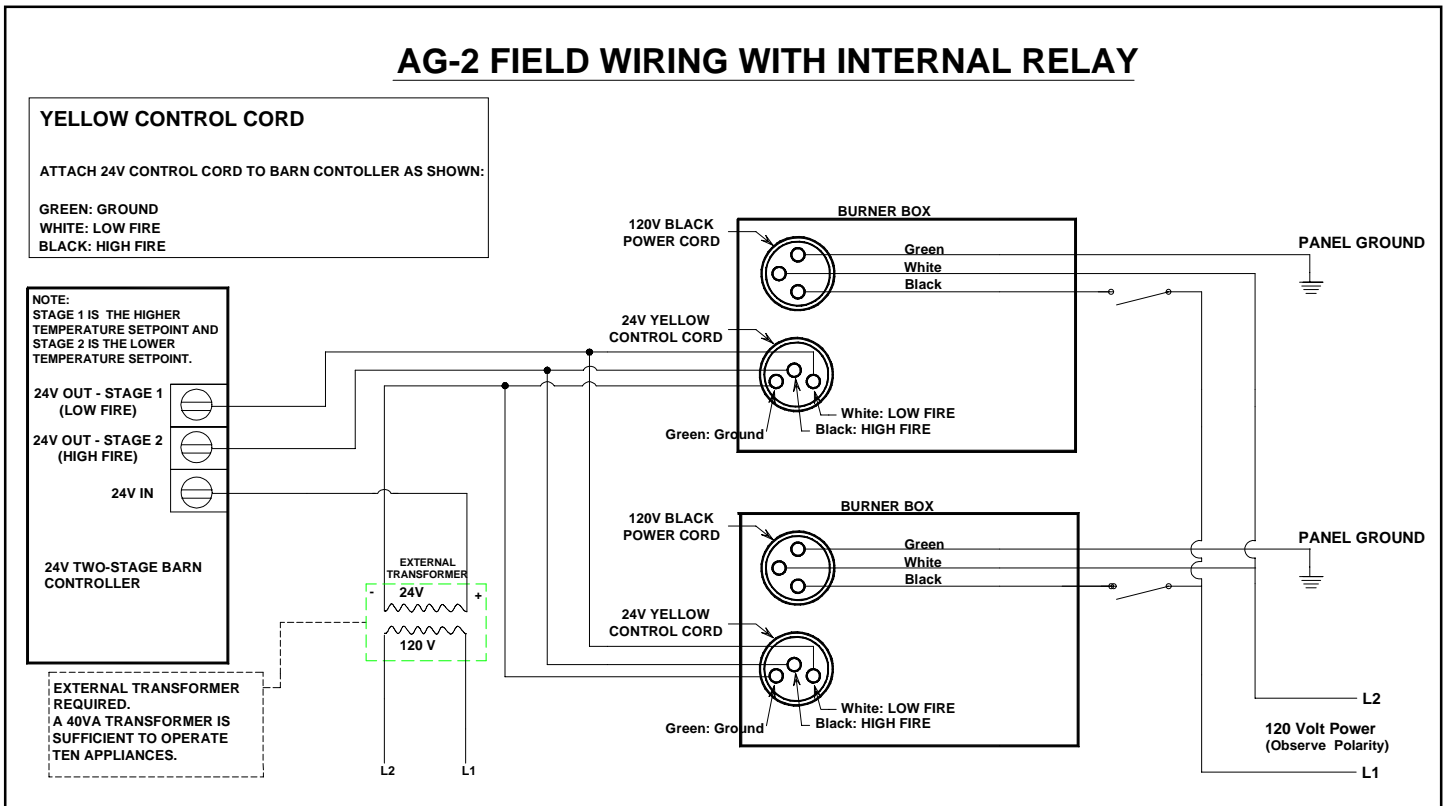

TYPICAL WIRING DIAGRAM TO BARN CONTROLLER

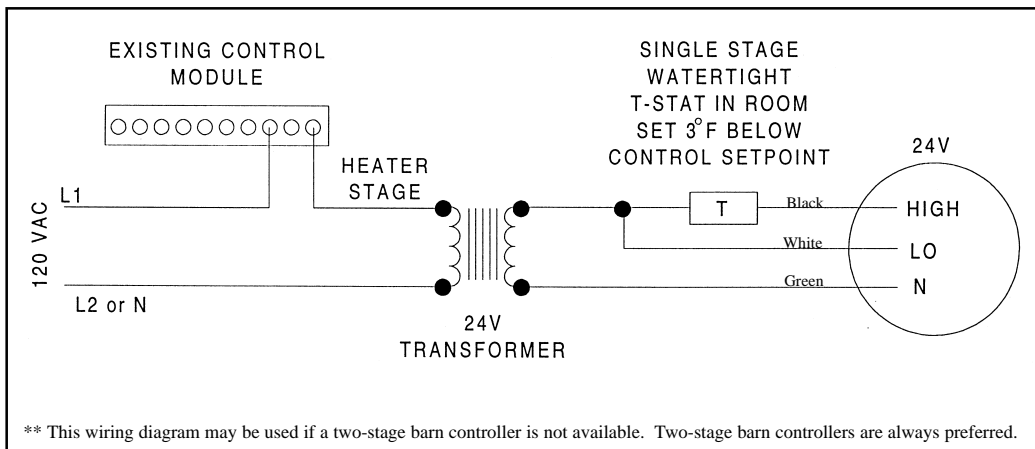

TWO-STAGE CONTROL WIRING WITH SINGLE STAGE BARN CONTROLLER

Electrician: 24V must be field supplied to each unit's yellow cord. Supply 120V to black cord. Observe polarity. Confirm proper two stage electrical wiring by cycling heaters between stages. Proper operation of high fire, low fire and off should be confirmed on all two stage AG-2 Heaters. AG-2 model heaters require a 24-volt two-stage thermostat / controller to operate.

Alternative Wiring Diagrams

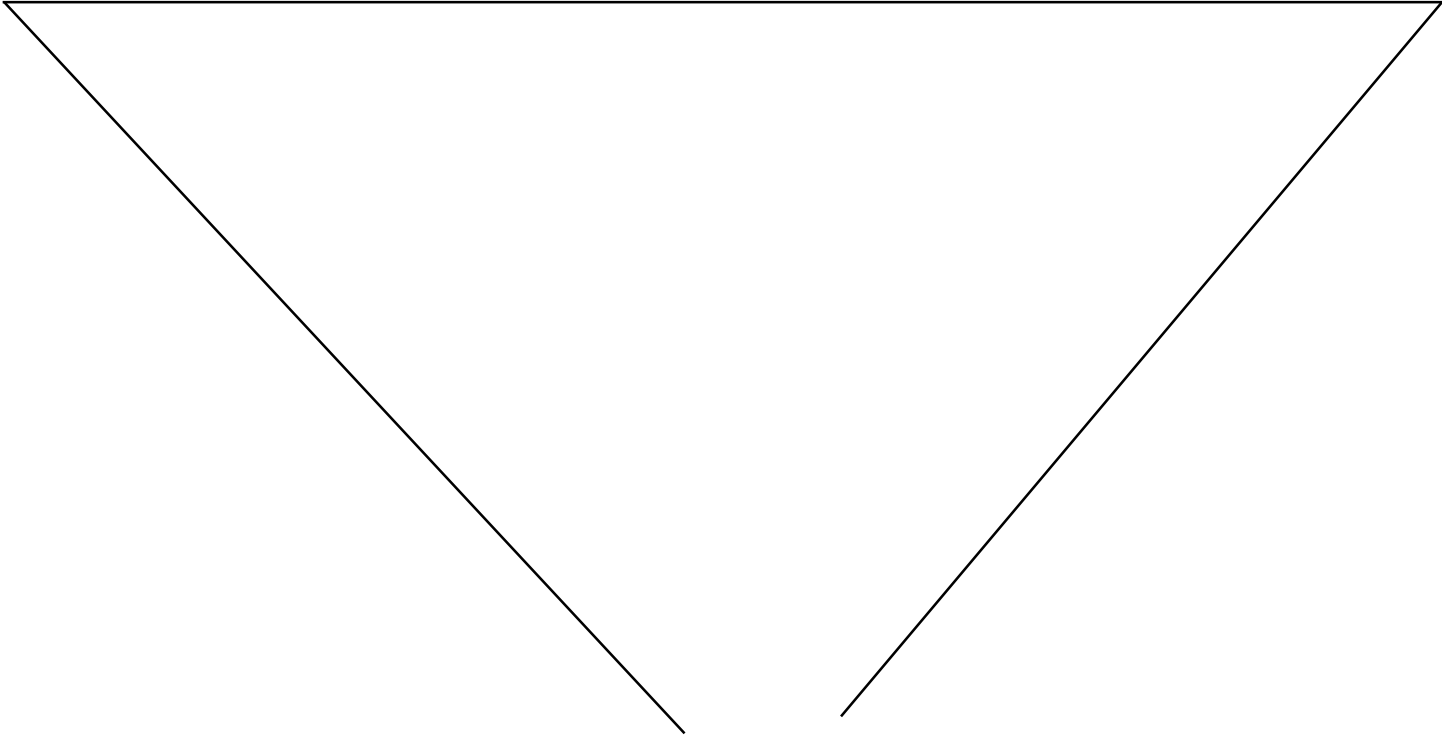

THIS PAGE INTENTIONALLY LEFT BLANK.
THERE ARE NO ALTERNATIVE WIRING DIAGRAMS FOR THE AG-2 SERIES

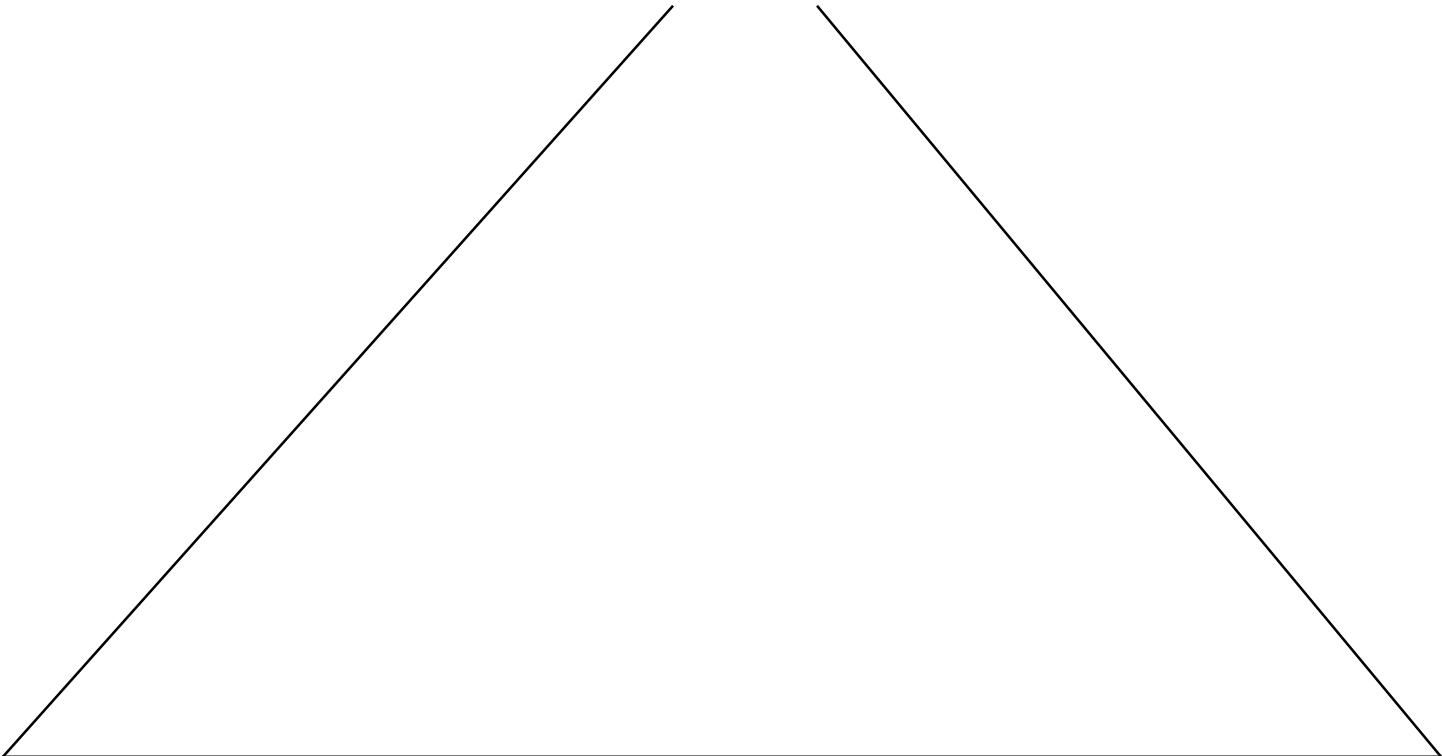

AG-2 Troubleshooting Flow Chart

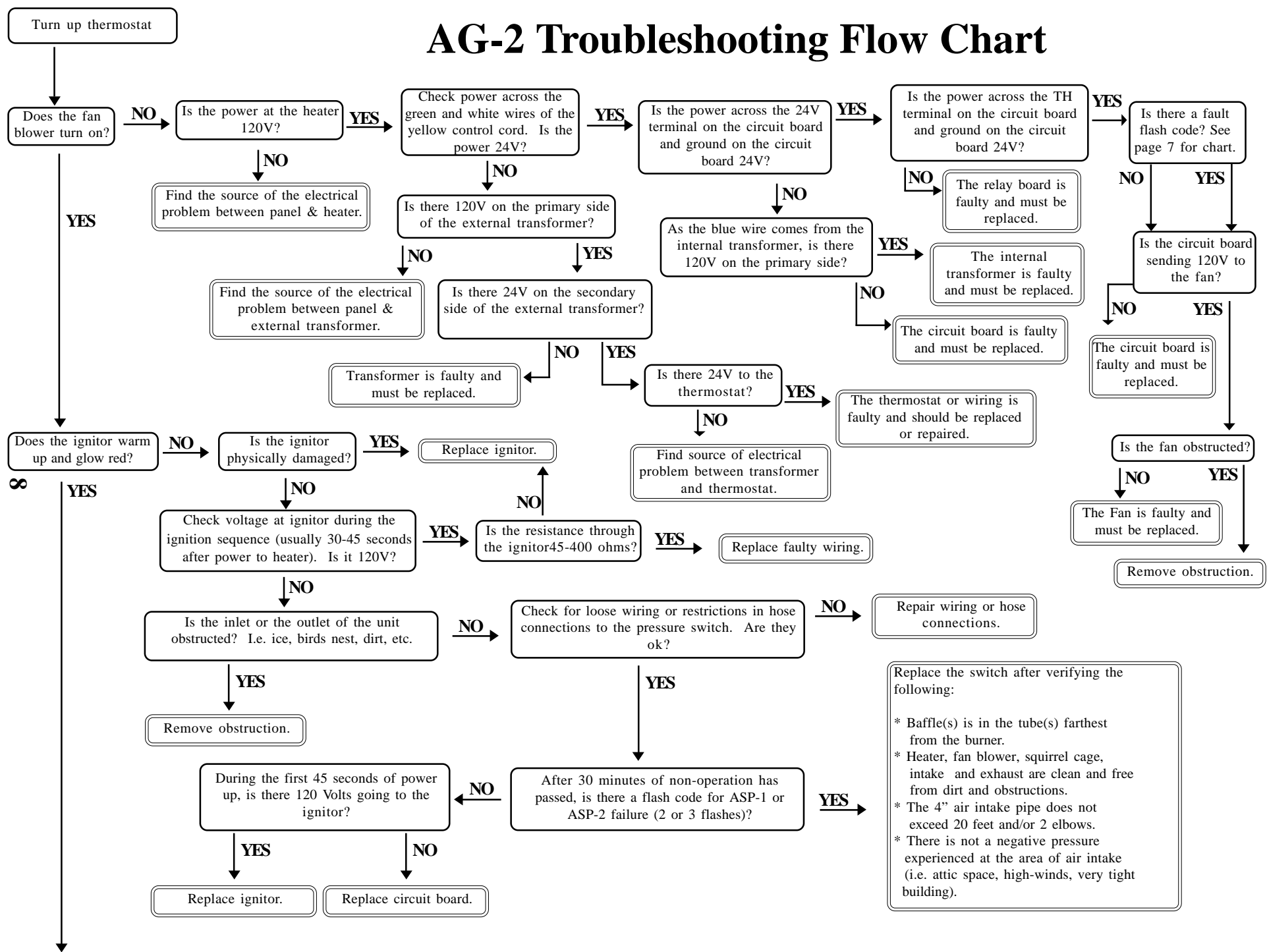

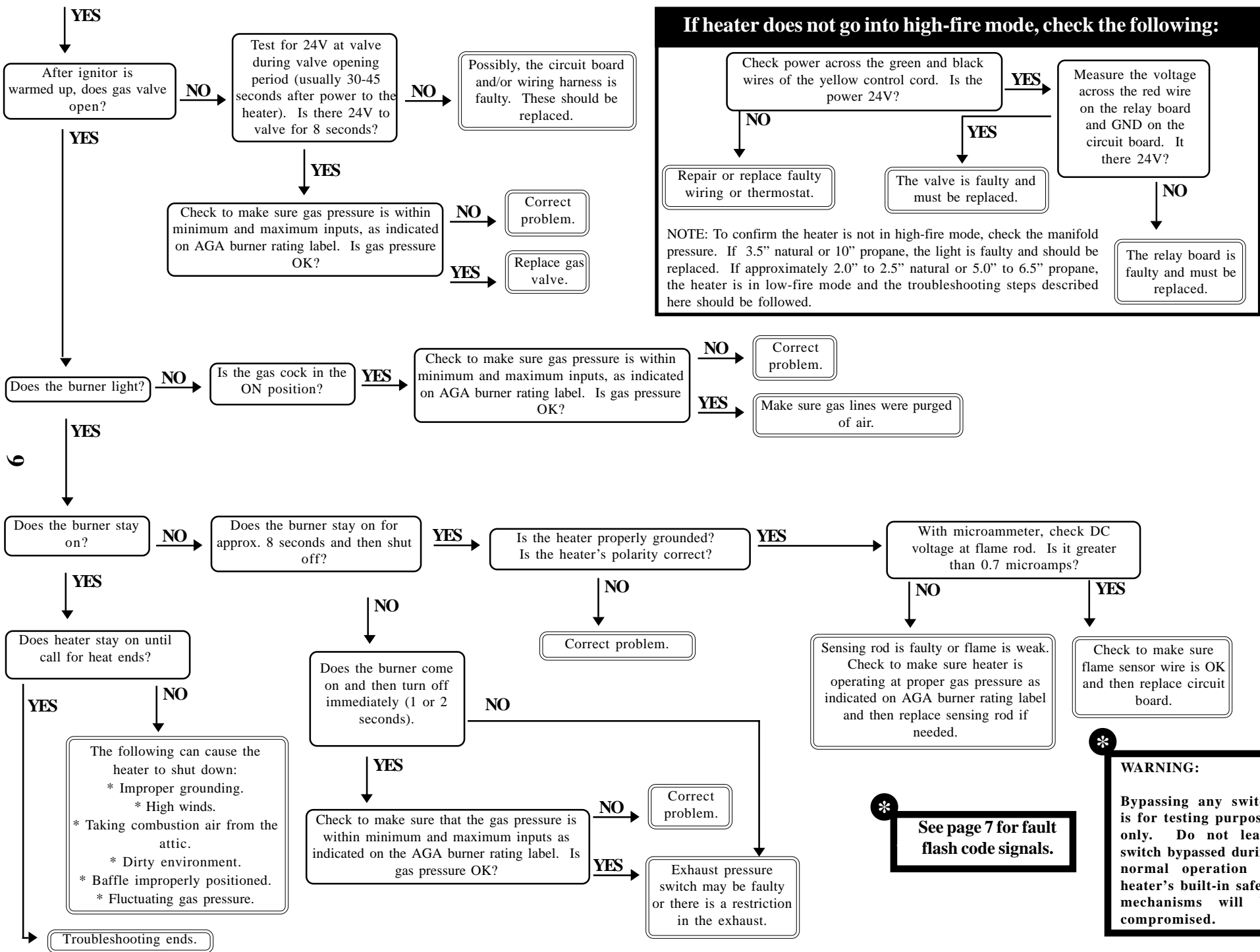

If heater does not go into high-fire mode, check the following:

Check power across the green and black wires of the yellow control cord. Is the power 24V?

NO → Repair or replace faulty wiring or thermostat.

YES → Measure the voltage across the red wire on the relay board and GND on the circuit board. Is there 24V?

NO → The relay board is faulty and must be replaced.

YES → The valve is faulty and must be replaced.

NOTE: To confirm the heater is not in high-fire mode, check the manifold pressure. If 3.5" natural or 10" propane, the light is faulty and should be replaced. If approximately 2.0" to 2.5" natural or 5.0" to 6.5" propane, the heater is in low-fire mode and the troubleshooting steps described here should be followed.

*** See page 7 for fault flash code signals.**

*** WARNING:**
Bypassing any switch is for testing purposes only. Do not leave switch bypassed during normal operation or heater's built-in safety mechanisms will be compromised.

AG-2 Series

Parts Breakdown

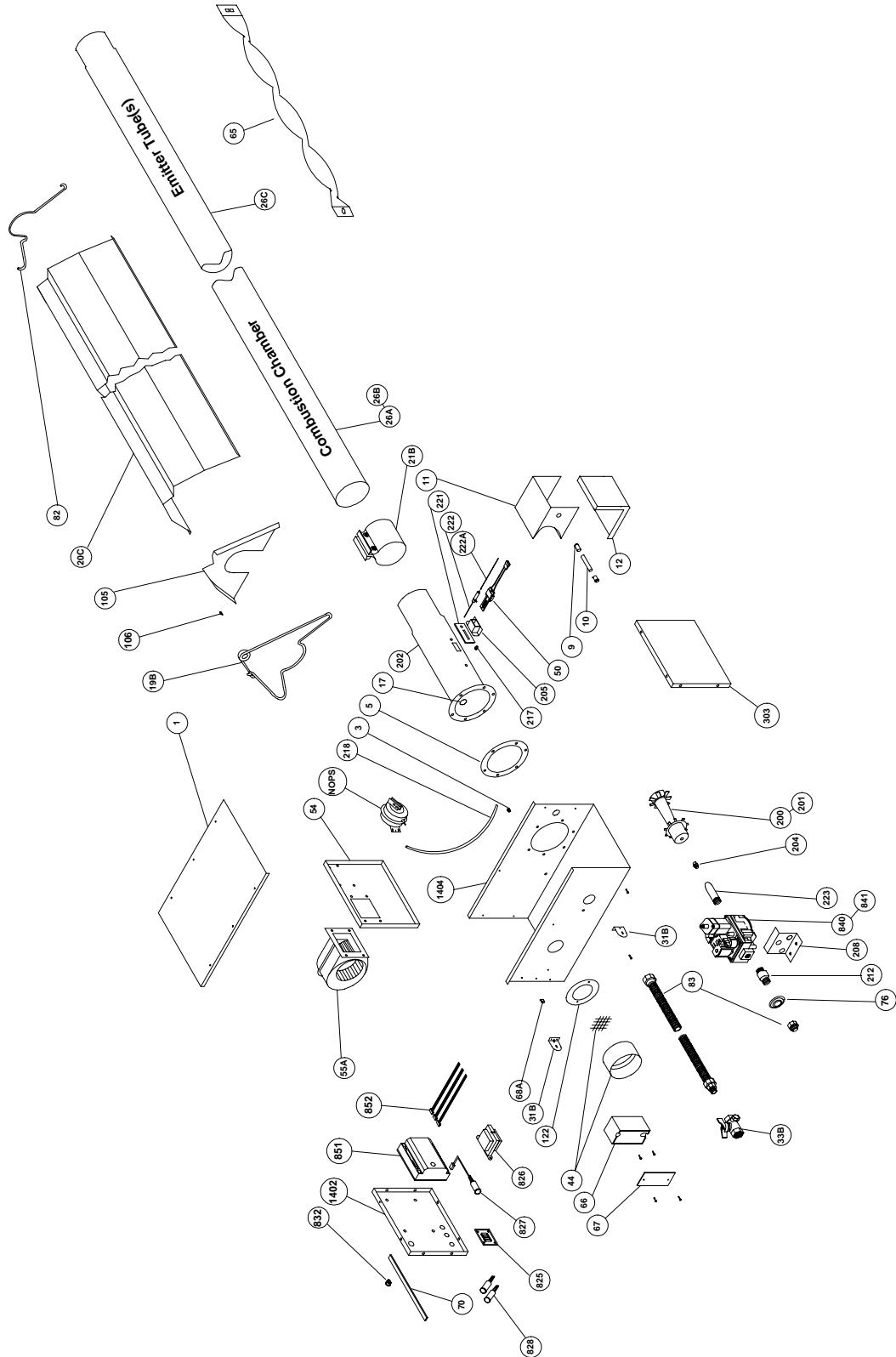



AG-2 SERIES PARTS LISTING

TP#	ITEM	TP#	ITEM
TP-1	CONTROL BOX COVER	TP-200	BURNER (50 TO 100 MBTU/H)
TP-5	FLANGE GASKET	TP-201	BURNER (125 MBTU/H TO 200 MBTU/H)
TP-9	CONDUIT COUPLING	TP-202	16" BURNER TUBE W/ FLANGE
TP-10	CONDUIT 4" X 1/2"	TP-204	GAS ORIFICE - CONSULT FACTORY
TP-11	GLO-BAR IGNITOR BOX	TP-205	GLO-BAR HOLDER
TP-12	GLO-BAR IGNITOR BOX COVER	TP-208	"Z" MOUNTING BRACKET
TP-17	SIGHT GLASS KIT	TP-211	MARK 17X-24 CIRCUIT BOARD
TP-19B	WIRE HANGER	TP-211A	MARK 17U-24 CIRCUIT BOARD (REMOTE SENSE)
TP-20C	120" REFLECTOR	TP-212	1/2" X 3" PIPE NIPPLE
TP-21B	TUBE CLAMP	TP-214	GLO-BAR WIRING HARNESS
TP-26A	10 FT. RADIANT TUBE STRAIGHT	TP-217	PRESSURE BARB FITTING
TP-26B	10 FT. RADIANT TUBE STRAIGHT (AL-TI)	TP-218	EXHAUST PRESSURE TUBE (VINYL)
TP-26C	10 FT. UNCOATED HOT ROLLED STEEL RADIANT TUBE	TP-221	GLO-BAR HOLDER GASKET
TP-31B	CONTROL BOX BRACKET	TP-222	FLAME ROD
TP-33B	1/2" GAS COCK	TP-222A	FLAME ROD WIRE
TP-44	AIR ORIFICE W/SCREEN (CONSULT FACTORY)	TP-223	GAS MANIFOLD
TP-50	GLO-BAR IGNITOR	TP-303	END PANEL - RIGHT
TP-54	BURNER BOX DIVIDER	TP-825	HLRB RELAY BOARD
TP-55A	FAN BLOWER	TP-826	40VA TRANSFORMER (OLD TP219)
TP-65	33" INTERLOCKING HEAT DIFFUSER (BAFFLE)	TP-827	RED LED DISPLAY DIAGNOSTIC LIGHT
TP-66	2" X 4" OUTLET BOX	TP-828	YELLOW OPERATIONAL IND. LIGHT (OLD TP216)
TP-67	2" X 4" OUTLET BOX COVER	TP-832	THERMOSTAT TERMINAL STRIP (OLD TP213)
TP-68A	STRAIN RELIEF BUSHING	TP-840	36E96-224 TWO STAGE GAS VALVE-NAT (OLD TP210)
TP-70	CONTROL BOX COVER GASKET (PER FOOT**)	TP-841	36E96-226 TWO STAGE GAS VALVE-LP (OLD TP210P)
TP-76	RUBBER GROMMET	TP-851	MICRO-60-24 DIAGNOSTIC CIRCUIT BOARD
TP-82	REFLECTOR CENTER SUPPORT	TP-852	WIRE HARNESS SET (3 PCS.) FOR MICRO 60 BOARD
TP-83	STAINLESS STEEL FLEX CONNECTOR	TP-1402	END PANEL - LEFT
TP-105	REFLECTOR END CAP	TP-1404	CONTROL BOX
TP-106	REFLECTOR CLIP	TP-NOPS	NORMALLY OPEN DIFFERENTIAL SWITCH
TP-108	5' AL-TI TUBE, PAINTED W. ONE CLAMP	(TP-61B)	N.O. Differential Pressure Switch (65 TO 75MBTU/H)
TP-111	5' ALUM. TUBE, PAINTED W/1 CLAMP	(TP-61E)	N.O. Differential Pressure Switch (100 TO 125MBTU/H)
TP-112	5' REFLECTOR	(TP-61D)	N.O. Differential Pressure Switch (150MBTU/H)
TP-122	GASKET FOR AIR ORIFICE & AIR COLLAR		



Kit Contents & Product Features

Kit contents for the AG-2 Series are shown below. Reference the proper column for your particular models length.

FILLED BY:		AG-2 SERIES KIT CONTENTS				
TP#	DESCRIPTION	20 FOOT	30 FOOT	40 FOOT	50 FOOT	60 FOOT
TP-19B	4" Hangers	3	4	5	6	7
TP-21B	4" Tube Clamps	2	3	4	5	6
TP-33B	1/2" Gas Cock	1	1	1	1	1
TP-82	4" Refl. Cntr. Sprt.	1	1	1	1	1
TP-83	24" SS Flex Line	1	1	1	1	1
TP-105	Refl. End caps	2	2	2	2	2
TP-106	Refl. End cap Clips	8	8	8	8	8
IOM	Install / Op Manual	1	1	1	1	1



4" Hanger
TP-19B



4" Butt Clamp
TP-21B



Gas Cock
1/2" TP-33B



Bag of Reflector
End Cap Clips.
TP-106



24" SS Flex
Connect TP-83



Reflector End
Caps TP-105

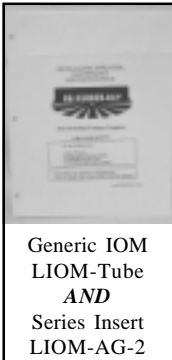

Generic IOM
LIOM-Tube
AND
Series Insert
LIOM-AG-2

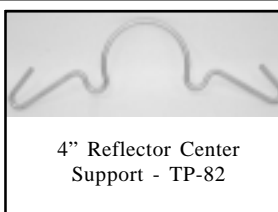

4" Reflector Center
Support - TP-82

Product Features

APPROVALS

- IAS, AGA.
- Indoor approval.
- Commercial approval.

BURNER SIGHT GLASS

- For burner inspection.

COMBUSTION AIR INLET & VENT

- 4" Male duct.

WATERPROOFED CONTROL BOX

- Outside air collar (4") attached.
- Totally enclosed components.

CONTROLS

- 100% safety shut off.
- Dual differential pressure switches.
- Stainless steel flame swirl burner.
- Silicon carbide hot surface igniter.
- Flame rod sensing.
- Pre and post purge controls.
- Microprocessor circuit board provides soft lockout and self-diagnostic features.

EMITTER & COMBUSTION TUBES

- 16ga. 4" O.D. hot rolled steel.
- Slip fit connection.
- Aluminized combustion chamber (50-125 MBTU/H models).
- Titanium combustion chamber (150 MBTU/H models).

GAS CONNECTION

- 1/2" gas cock included.
- 7/8" flare-2' S.S. flex included.

WARRANTY

1 year - Burner box components.
3 years - Combustion and radiant tubes.
5 years - Burner.

*See cover for warranty registration information

OTHER

- One reflector center support per heater.
- Turbulator baffle included.
- Stainless steel upgrades available.
- Made in U.S.A
- Visit www.reverberray.com for parts information.