

# DES Series - 4" Tube Heater Installation, Operation, Maintenance and Parts Manual\*

**▲ WARNING: This heater must be installed and serviced by trained gas installation and service personnel only! Improper installation, adjustment, alteration, service or maintenance can cause property damage, injury or death. Read the installation, operating and maintenance instructions thoroughly before installing or servicing this equipment. Protect yourself and others by observing all safety information. Retain instructions for future reference.**

\*For complete installation instructions, see the General Manual that accompanied this piece. Also available at [www.reverberray.com](http://www.reverberray.com).

## DES Series

Project: \_\_\_\_\_ Date: \_\_\_\_\_  
 Location: \_\_\_\_\_  
 City: \_\_\_\_\_ State: \_\_\_\_\_ Zip: \_\_\_\_\_  
 Contractor: \_\_\_\_\_  
 Engineer: \_\_\_\_\_  
 Local Representative: \_\_\_\_\_  
 Customer Name: \_\_\_\_\_  
 Address: \_\_\_\_\_  
 City: \_\_\_\_\_ State: \_\_\_\_\_ Zip: \_\_\_\_\_  
 Model #: \_\_\_\_\_ Phone#: \_\_\_\_\_  
 Serial #: \_\_\_\_\_ Date of Install: \_\_\_\_\_  
 Notes: \_\_\_\_\_

Table of Contents	
	Page
Models	1
Warnings	2
Clearances to Combustibles	2
Product Summary	3
Product Instructions	3
Heater Requirements	4
Theory of Operation	4
Wiring Diagrams	5-7
Flowchart	8-9
Parts Listing	10-11
Series Kit Contents	12

## Models

Qty.	Model #	Gas Type (circle one)	BTU/H	Straight Length	U-Tube Length	Weight	Typical Mount Height	Combustion Chamber	Radiant Emitter Tube	"Type" Tube Pkg #1	"Type" Tube Pkg. #2	Baffle Pieces
	DES 20-50	N or LP	50,000	21'-7"	13'-0"	120 #	10' - 15'	Aluminized	4" Hot-rolled	20-4 Alum-HRT	N/A	5
	DES 20-60	N or LP	60,000	21'-7"	13'-0"	120 #	11' - 18'	Aluminized	4" Hot-rolled	20-4 Alum-HRT	N/A	5
	DES 20-75	N or LP	75,000	21'-7"	13'-0"	120 #	12' - 20'	Aluminized	4" Hot-rolled	20-4 Alum-HRT	N/A	5
	DES 30-50	N or LP	50,000	31'-3"	*17'-8"	120 #	10' - 15'	Aluminized	4" Hot-rolled	30-4 Alum-HRT	N/A	4
	DES 30-60	N or LP	60,000	31'-3"	*17'-8"	160 #	11' - 18'	Aluminized	4" Hot-rolled	30-4 Alum-HRT	N/A	4
	DES 30-75	N or LP	75,000	31'-3"	*17'-8"	160 #	12' - 20'	Aluminized	4" Hot-rolled	30-4 Alum-HRT	N/A	4
	DES 30-100	N or LP	100,000	31'-3"	*17'-8"	160 #	13' - 23'	Aluminized	4" Hot-rolled	30-4 Alum-HRT	N/A	5
	DES 40-50	N or LP	50,000	40'-11"	22'-8"	190 #	10' - 15'	Aluminized	4" Hot-rolled	40-4 Alum-HRT	N/A	2
	DES 40-60	N or LP	60,000	40'-11"	22'-8"	190 #	11' - 18'	Aluminized	4" Hot-rolled	40-4 Alum-HRT	N/A	2
	DES 40-75	N or LP	75,000	40'-11"	22'-8"	190 #	12' - 20'	Aluminized	4" Hot-rolled	40-4 Alum-HRT	N/A	2
	DES 40-100	N or LP	100,000	40'-11"	22'-8"	190 #	13' - 23'	Aluminized	4" Hot-rolled	40-4 Alum-HRT	N/A	4
	DES 40-125	N or LP	125,000	40'-11"	22'-8"	190 #	15' - 25'	Aluminized	4" Hot-rolled	40-4 Alum-HRT	N/A	4
	DES 40-150	N or LP	150,000	40'-11"	22'-8"	190 #	16' - 30'	Titanium	4" Hot-rolled	40-4 Titan-HRT	N/A	4
	DES 50-100	N or LP	100,000	50'-7"	*27'-4"	235 #	13' - 23'	Aluminized	4" Hot-rolled	40-4 Alum-HRT	10-4-HRT	2
	DES 50-125	N or LP	125,000	50'-7"	*27'-4"	235 #	15' - 25'	Aluminized	4" Hot-rolled	40-4 Alum-HRT	10-4-HRT	4
	DES 50-150	N or LP	150,000	50'-7"	*27'-4"	235 #	16' - 30'	Titanium	4" Hot-rolled	40-4 Titan-HRT	10-4-HRT	4
	DES 50-175	N or LP	175,000	50'-7"	*27'-4"	235 #	17' - 35'	Titanium	4" Hot-rolled	40-4 Titan-HRT	10-4-HRT	2
	DES 60-125	N or LP	125,000	60'-3"	32'-4"	235 #	15' - 25'	Aluminized	4" Hot-rolled	40-4 Alum-HRT	20-4-HRT	2
	DES 60-150	N or LP	150,000	60'-3"	32'-4"	235 #	16' - 30'	Titanium	4" Hot-rolled	40-4 Titan-HRT	20-4-HRT	2
	DES 60-175	N or LP	175,000	60'-3"	32'-4"	235 #	17' - 35'	Titanium	4" Hot-rolled	40-4 Titan-HRT	20-4-HRT	2

\* Model requires 5EA-SUB accessory package.

### Warranty registration options:

1. Register online at [www.reverberray.com/warranty](http://www.reverberray.com/warranty)
2. Complete the information above and fax to Detroit Radiant Products Co.
3. Complete the information above and mail to Detroit Radiant Products Co.



# DES Series

**▲ WARNING!**

**NOT FOR RESIDENTIAL USE!**

Do not use in the home, sleeping quarters, attached garages, etc.

**▲ WARNING!**

This heater must be installed and serviced by trained gas installation and service personnel only. Read and understand these instructions thoroughly before attempting to install, operate or service this heater. Failure to comply could result in personal injury, asphyxiation, death, fire, and/or property damage. Retain these instructions for future reference.

**▲ WARNING!**

This is not an explosion-proof heater. Where there is the possibility of exposure to flammable vapors, consult the local fire marshal, the fire insurance carrier and other authorities for approval of the proposed installation.

**▲ WARNING!**

Failure to comply with the stated clearances to combustibles could result in personal injury, death and/or property damage.

**▲ WARNING!**

In locations used for the storage of combustible materials, signs must be posted to specify the maximum permissible stacking height to maintain the required clearances from the heater to the combustibles. Signs must either be posted adjacent to the heater thermostats or in the absence of such thermostats, in a conspicuous location.

**▲ WARNING!**

This heater should be installed so that the minimum clearances to vehicles, as marked on the heater, will be maintained. If vehicle lifts are present, ensure that these clearances will be maintained from the highest raised vehicle.

**CLEARANCES TO COMBUSTIBLES (IN.)**

MODEL NO.	MOUNTING ANGLE	SIDE		TOP	BELOW
		FRONT	BEHIND		
DES(20,30,40)-50 [N,P]	0°	9	9	6	47
	45°	39	8	10	47
	W/1 side shield	0°	29	8	6
DES(20,30,40)-60 [N,P]	0°	9	9	6	47
	45°	39	8	10	47
	W/1 side shield	0°	29	8	6
DES(20,30,40)-75 [N,P]	0°	9	9	6	60
	45°	39	8	10	60
	W/1 side shield	0°	29	8	6
DES(30,40,50)-100 [N,P]	0°	14	14	6	66
	45°	39	8	10	66
	W/1 side shield	0°	29	8	6
DES(40,50,60)-125 [N,P]	0°	20	20	6	76
	45°	58	8	10	76
	W/1 side shield	0°	42	8	6
DES(40,50,60)-150 [N,P]	0°	24	24	6	81
	45°	58	8	10	81
	W/1 side shield	0°	42	8	6
DES(50,60)-175 [N,P]	0°	34	34	6	92
	45°	63	8	10	92
	W/1 side shield	0°	50	8	6
	0°	30	30	6	92
	0°	11	11	6	44
	0°	11	11	6	44

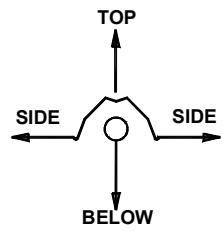

0° MOUNTING ANGLE

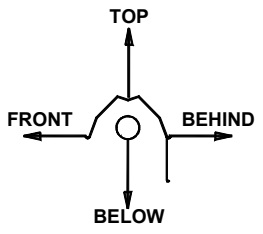

0° W/1 SIDE SHIELD

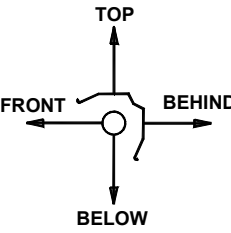

45° MOUNTING ANGLE

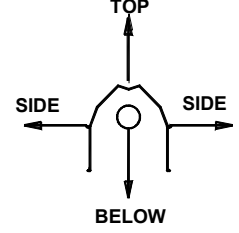

0° W/2 SIDE SHIELDS

# DES Series Mechanical Instructions

This supplement is designed to address the specifics of the DES Series - See page 12 for specific product features.

## Product Summary

DES Series heaters are available from 20 to 60 foot, 50,000 to 175,000 BTU's, natural or LP gas. DES Series are positive pressure, single stage heaters and feature hot-rolled steel for it's radiant pipes. DES Series heaters also feature a direct spark ignition system.

## Specific Mechanical Instructions

Be sure to identify the aluminized (50 - 125 MBTU/H) or titanium (150 -175 MBTU/H) combustion chamber and place as the first tube section.

175,000 BTU/H models must be installed with a stainless steel tube clamp at the second joint of the exchanger between the first and second ten foot radiant tube.

Note baffle quantities for your model and place baffles in the last tubes (farthest from the burner) as shown on pages 13-14 of the general manual.

## Tube Installation Sequence

	Aluminized <small>(50-75 MBTU/H)</small>	Hot Rolled	B = Burner Location		* Baffle Location
B	Combustion Tube	*			
	Aluminized <small>(50-100 MBTU/H)</small>	Hot Rolled	Hot Rolled		
B	Combustion Tube		*		
	Aluminized or Titanium <small>(50-125 MBTU/H) (150 MBTU/H)</small>	Hot Rolled	Hot Rolled	Hot Rolled	
B	Combustion Tube			*	
	Aluminized or Titanium <small>(100-125 MBTU/H) (150-175 MBTU/H)</small>	Hot Rolled	Hot Rolled	Hot Rolled	Hot Rolled
B	Combustion Tube				*
	Aluminized or Titanium <small>(125 MBTU/H) (150-175 MBTU/H)</small>	Hot Rolled	Hot Rolled	Hot Rolled	Hot Rolled
B	Combustion Tube				*



# DES Series

---

## Electrical Requirements

- ◆ 120 Volt - 60 HZ, single phase, 3-wire.
- ◆ 25V thermostat connection.
- ◆ Starting Current 1.7 Amps.
- ◆ Running Current 1.1 Amps.
- ◆ 24V controls.
  
- ◆ Wiring must not run above or below the heater, nor exposed to the radiant output.
- ◆ Heaters must be grounded in accordance with the National Electrical Code ANSI/NFPA70 (latest edition).
- ◆ Observe proper electrical polarity.

It is recommended that the thermostat be installed on the hot side of a fused supply line and have sufficient ampere rating for the heater(s) that it controls.

## Gas Requirements

- ◆ Manifold Pressure
  - Nat. 3.5"   • LP. 10.0"
- ◆ Minimum Inlet Pressure
  - Nat. 5.0"   • LP. 11.0"
- ◆ Maximum Inlet
  - Nat. 14.0"   • LP. 14.0"

## Ventilation Requirements

- ◆ Consult the general manual for venting instructions.
  
- ◆ For unvented operation, there must be a positive air displacement of at least 4.0 CFM per 1000 BTU/H for natural gas or 4.5 CFM per 1000 BTU/H for LP gas. WVE-4 termination cap must also be used.

## Theory of Operation

- **Starting Circuit** (see internal wiring diagrams)

When voltage is applied to L1 and L2, a circuit is completed from L1 via the blower motor to L2. The blower fan is mounted in the control box and rated to supply sufficient air for combustion.

Air pressure generated by the blower will cause the normally open pressure switch to close. Another circuit is completed from L1 to the spark ignition module and back to L2. After a seven (7) second pre-purge, the spark electrode and gas valve are energized simultaneously. The trial for ignition is fifteen seconds.

- **Running Circuit**

After ignition, the flame rod monitors the flame. As long as a flame is present, the valve is held open. If the flame is lost, the control acts to close the valve within one second, and a new trial sequence identical to that at start-up is initiated. If proof of flame is not established within the 15 second trial for ignition, the unit will retry two additional times before entering lockout mode. If lockout occurs, the control can be reset by briefly interrupting the power source.

# Internal Wiring Diagrams

**DES LADDER DIAGRAM**

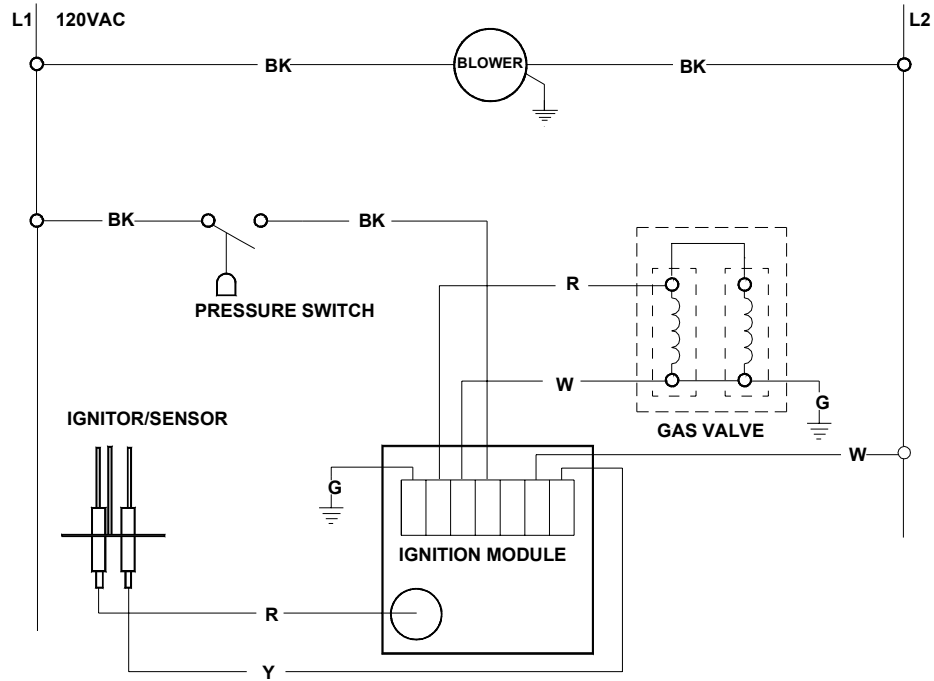

IF ANY OF THE ORIGINAL WIRE AS SUPPLIED WITH THE APPLIANCE MUST BE REPLACED, IT MUST BE REPLACED WITH WIRING MATERIAL HAVING A TEMPERATURE RATING OF AT LEAST 105 C.

**DES BLOCK DIAGRAM**

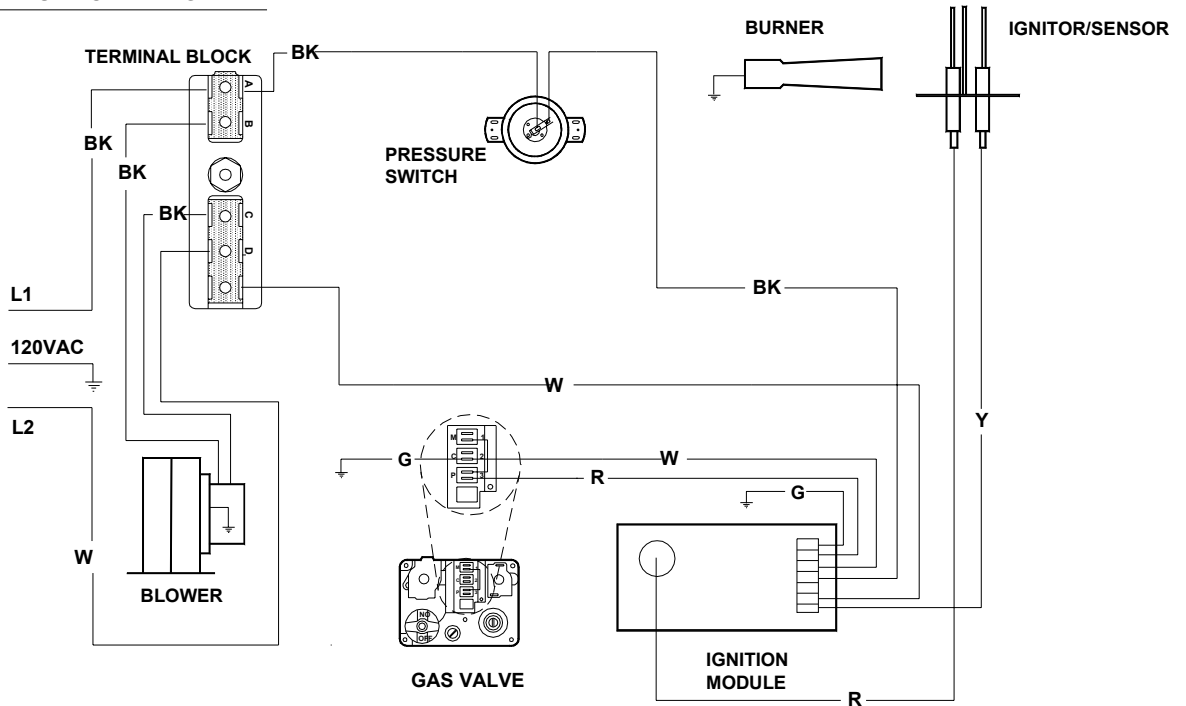

# DES Series

## Field Wiring Diagrams

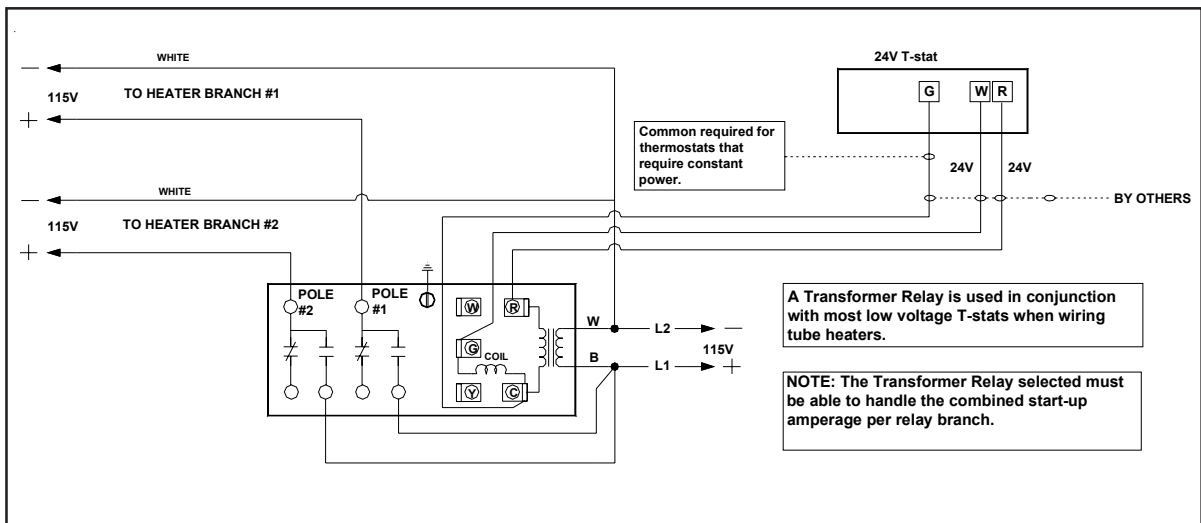

24V T-Stat & Connection(s)

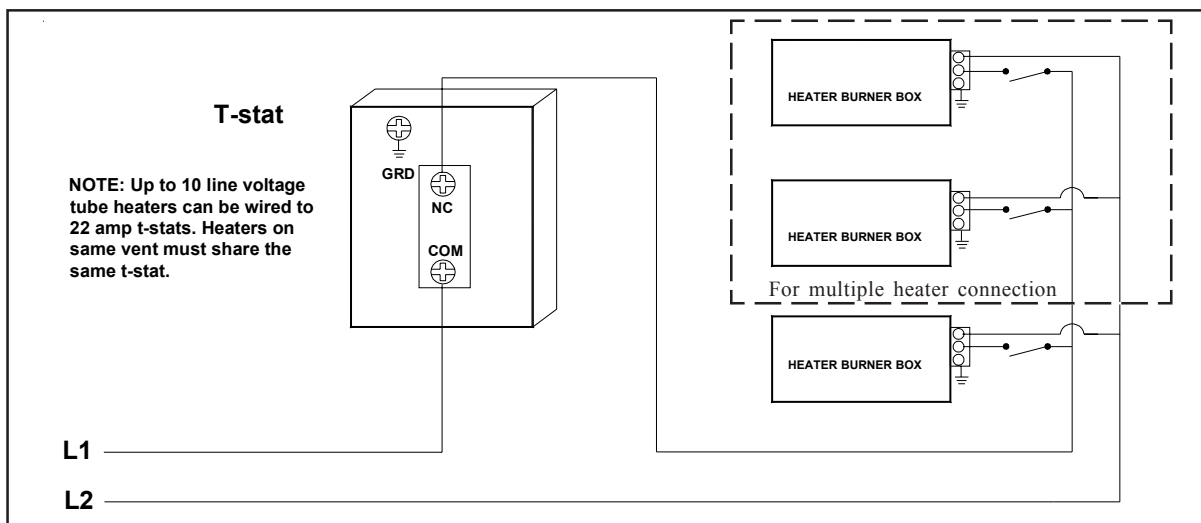

120V Connection(s)

## Alternative Wiring Diagrams

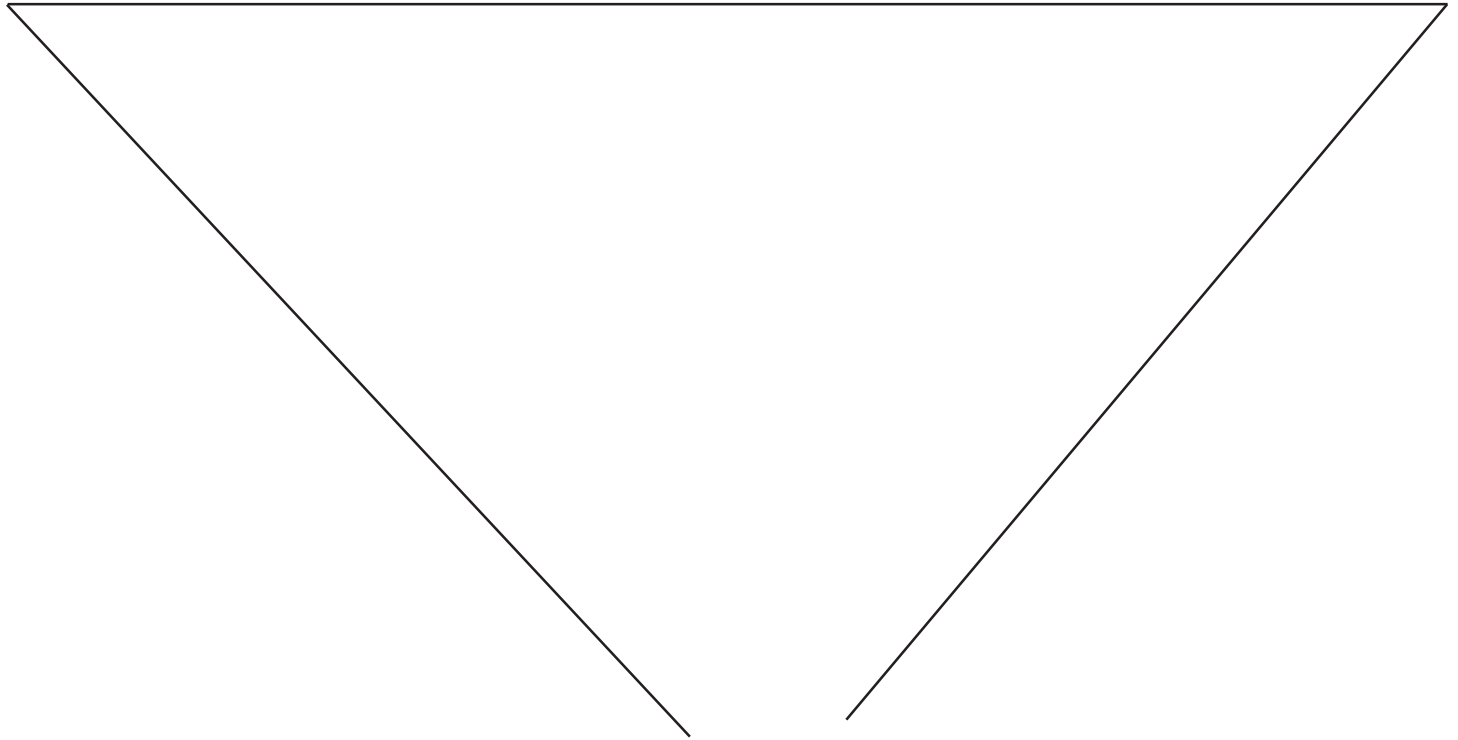

THIS PAGE INTENTIONALLY LEFT BLANK.  
THERE ARE NO ALTERNATIVE WIRING DIAGRAMS FOR THE DES SERIES

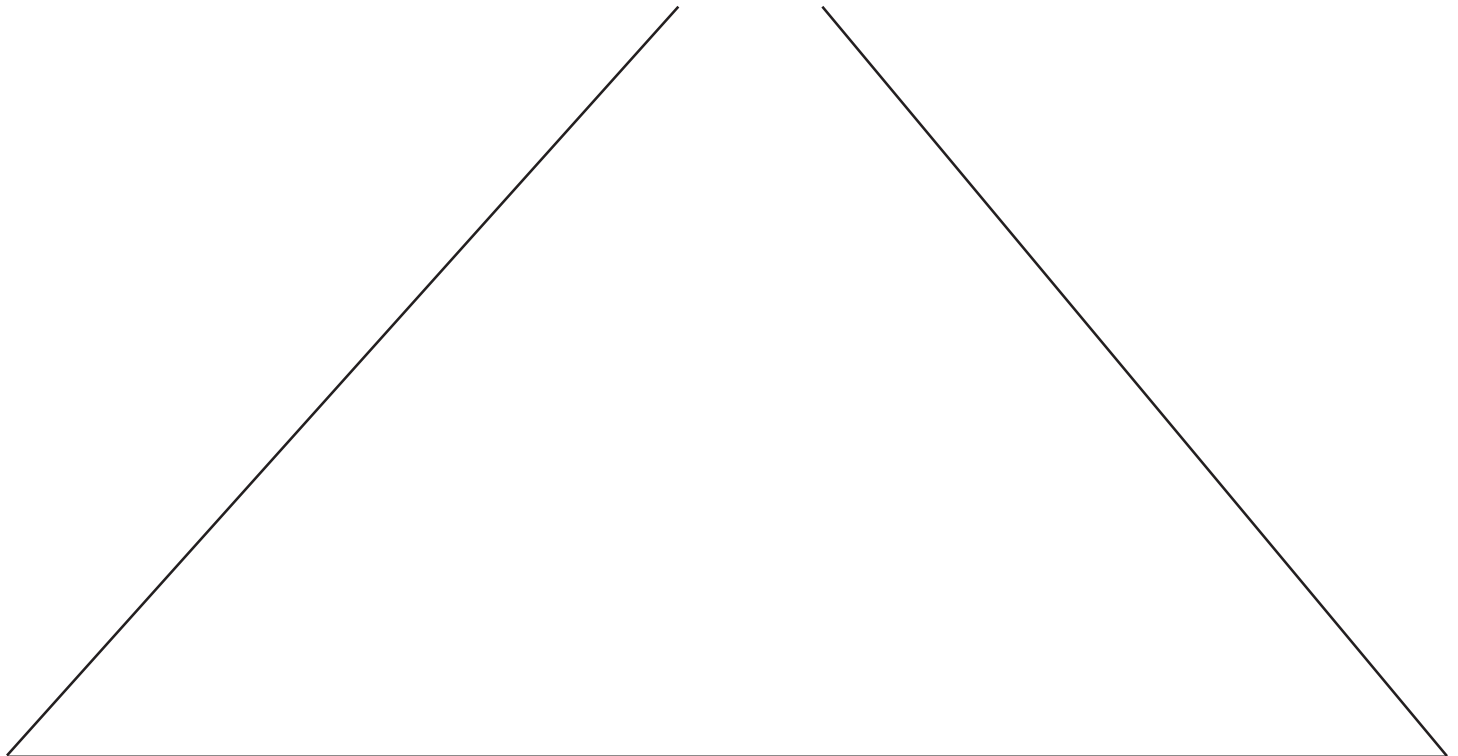

# DES Troubleshooting Flowchart

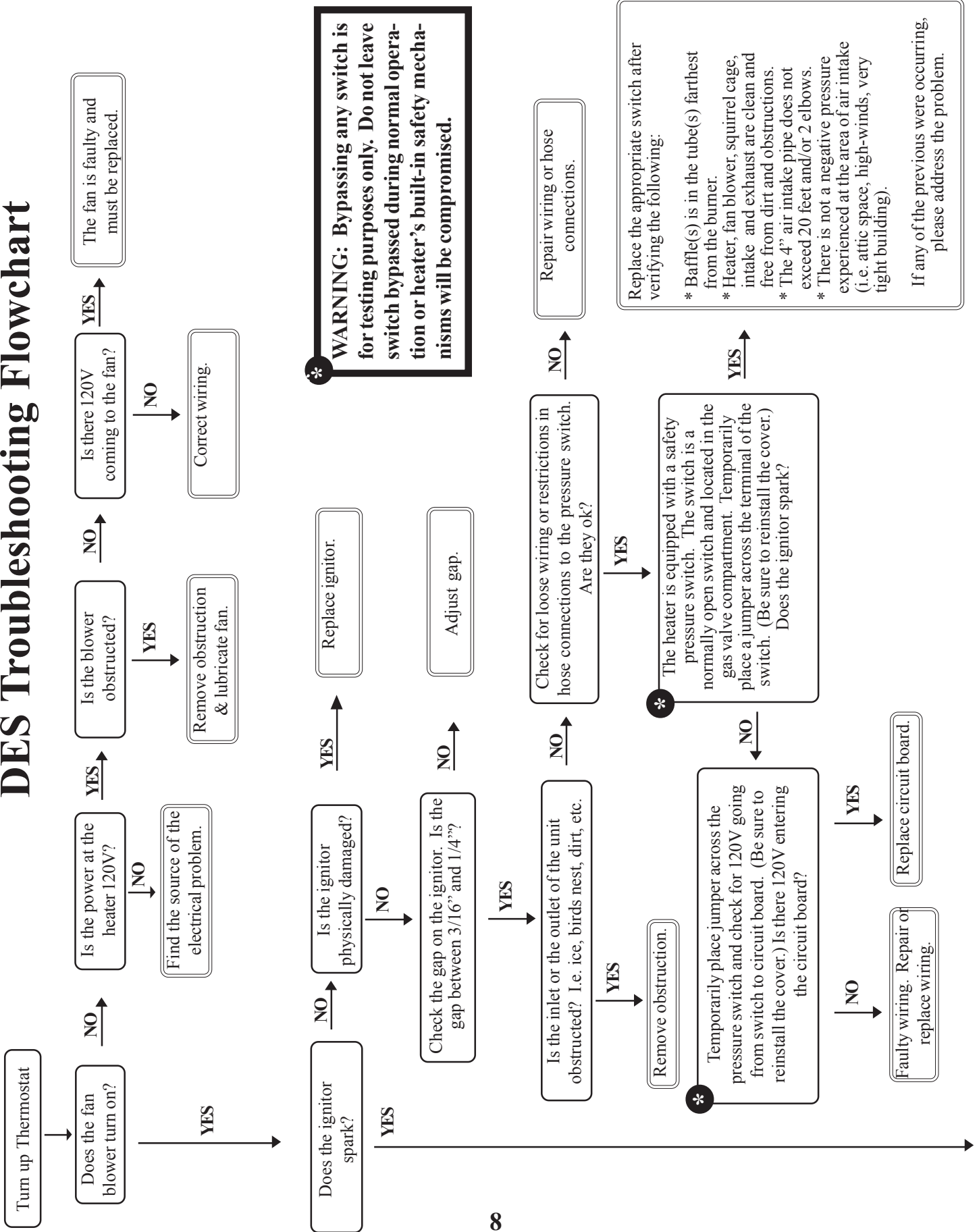

**\*WARNING: Bypassing any switch is for testing purposes only. Do not leave switch bypassed during normal operation or heater's built-in safety mechanisms will be compromised.**

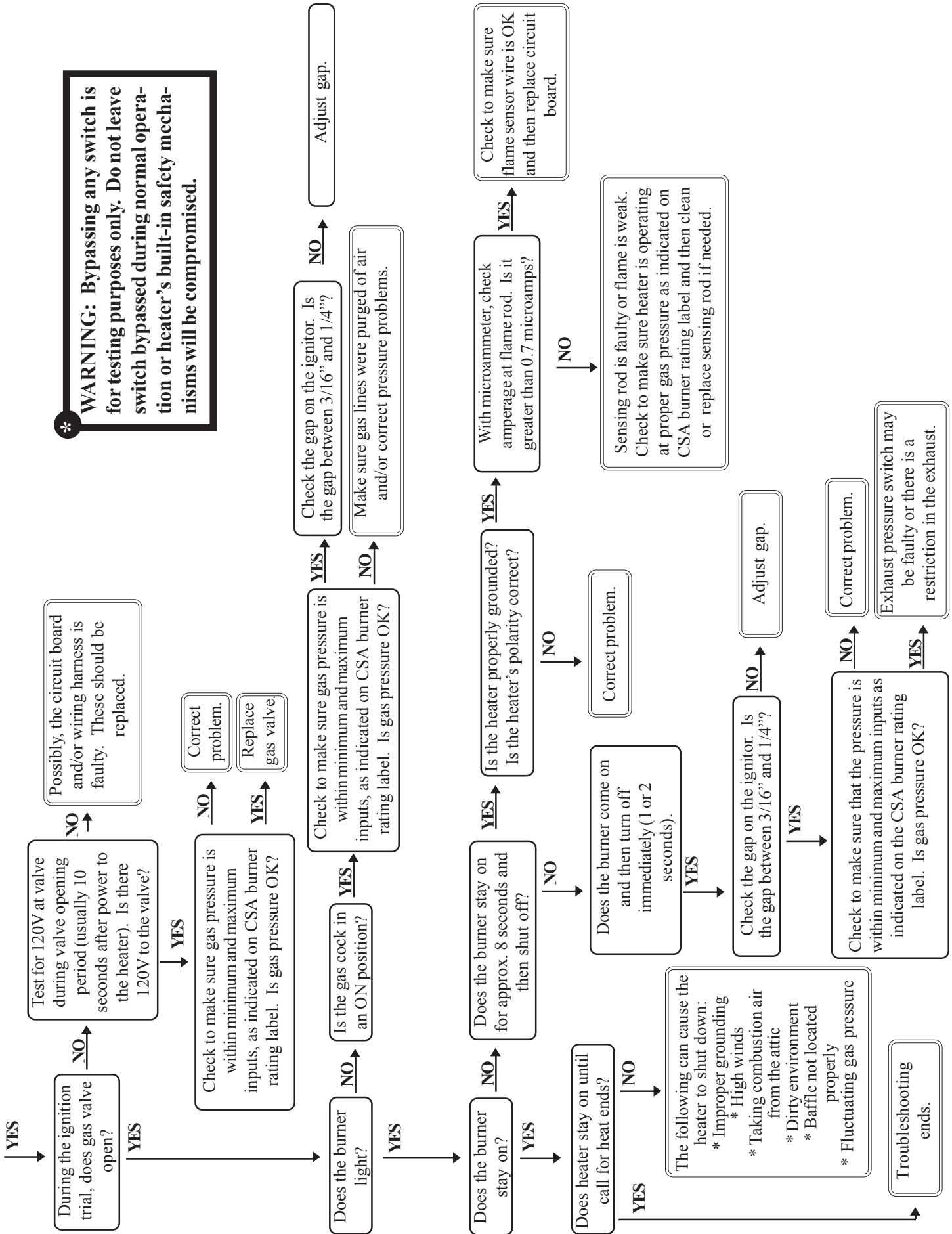

# DES Series

## Parts Breakdown

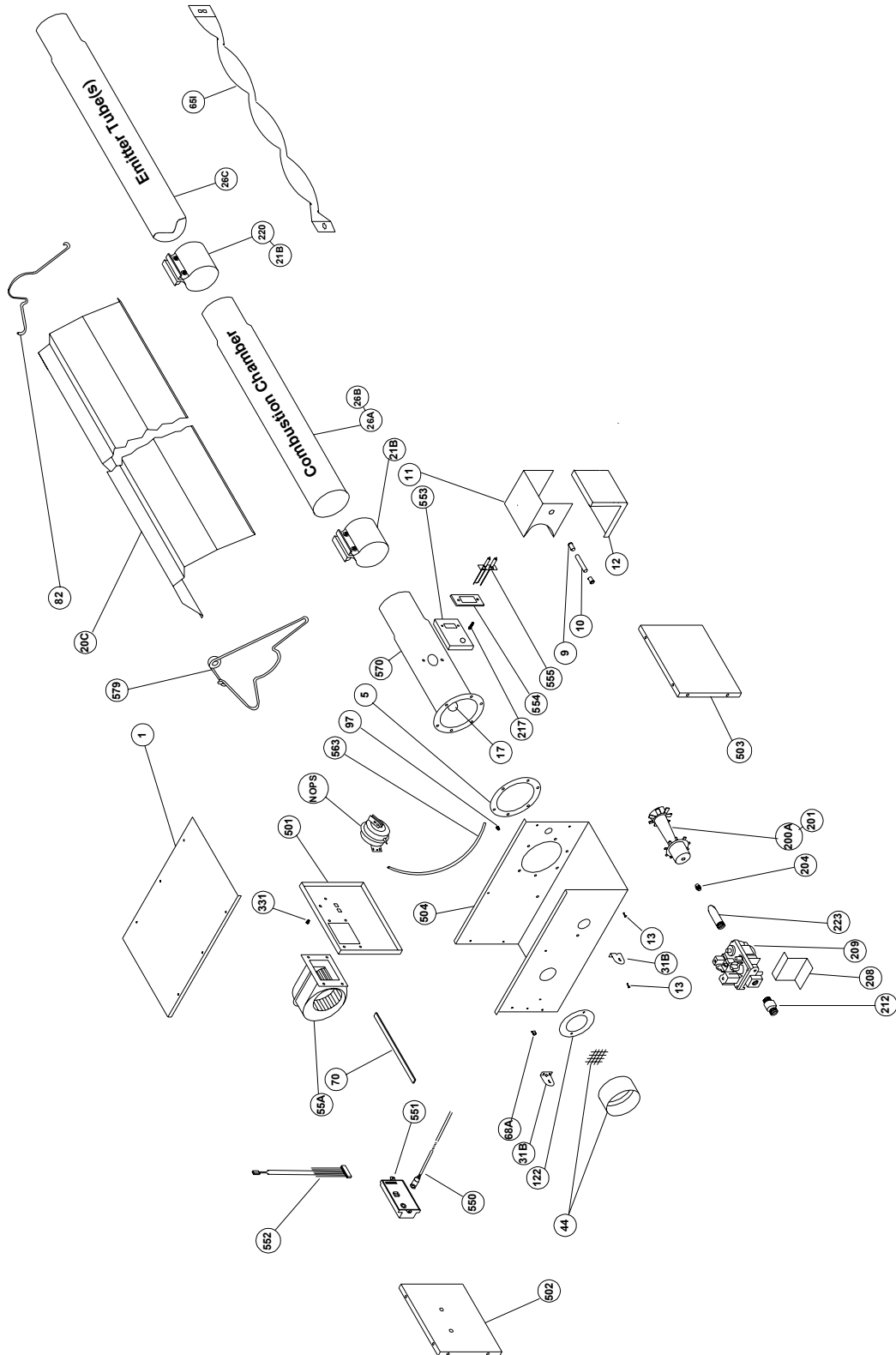

# Basic Parts List

## DES SERIES PARTS LISTING

TP#	ITEM	TP#	ITEM
TP-1	CONTROL BOX COVER	TP-208	"Z" MOUNTING BRACKET
TP-5	FLANGE GASKET	TP-209	36E36A-246 GAS VALVE - NAT GAS ASSY
TP-9	CONDUIT COUPLING	TP-209P	36E36A-240 GAS VALVE - LP GAS ASSY
TP-10	CONDUIT 4" X 1/2"	TP-212	1/2" X 3" PIPE NIPPLE
TP-11	IGNITOR BOX	TP-217	PRESSURE BARB FITTING
TP-12	IGNITOR BOX COVER	TP-222	FLAME ROD
TP-17	SIGHT GLASS KIT	TP-222A	FLAME ROD WIRE
TP-20C	120" ALUMINUM REFLECTOR	TP-223	GAS MANIFOLD
TP-20D	120" STAINLESS STEEL REFLECTOR	TP-330	DIVIDER GROMMET
TP-21B	4" TUBE CLAMP	TP-331	GREEN SELF TAP GROUND SCREW
TP-26A	10 FT. ALUMINIZED COMBUSTION TUBE	TP-501	DIVIDER PANEL
TP-26B	10 FT. TITANIUM COMBUSTION TUBE	TP-502	LEFT END PANEL
TP-26C	10FT. UNCOATED HOT ROLLED RADIANT TUBE	TP-503	RIGHT END PANELS
TP-31B	CONTROL BOX MOUNTING BRACKET	TP-504	CONTROL BOX
TP-44	AIR ORIFICE W/SCREEN - CONSULT FACTORY	TP-550	SPARK TRANSFER WIRE - ORANGE
TP-55A	FAN BLOWER	TP-551	MARK 10DX-117-10 CIRCUIT BOARD W/ PRE-PURGE
TP-65I	INTERLOCKING 33" BAFFLE SECTION	TP-552	WIRING HARNESS
TP-68A	STRAIN RELIEF BUSHING	TP-553	IGNITOR MOUNTING BRACKET
TP-70	CONTROL BOX COVER GASKET (PER FOOT**)	TP-554	SPARK IGNITOR GASKET
TP-82	REFLECTOR CENTER SUPPORT	TP-555	SPARK IGNITOR ELECTRODE
TP-97	1/4" x 1/4" BRASS INT./EXT. ATMOS. BARB FITTING	TP-562	1/4" ATMOSPHERIC TUBE (VINYL)
TP-108	5' AL-TI TUBE, PAINTED WITH ONE CLAMP	TP-563	1/4" PRESSURE TUBE
TP-111	5' ALUM. TUBE, PAINTED WITH ONE CLAMP	TP-570	16" DES BURNER TUBE WITH FLANGE
TP-112	5' REFLECTOR	TP-579	WIRE HANGER W/OUT SPRING CLIP
TP-122	GASKET FOR AIR ORIFICE & AIR COLLAR	<b>TP-NOPS</b>	<b>N.O. Pressure Switch (Select Switch Below, BTU Dependent)</b>
TP-200A	BURNER (50 TO 100 MBTU/H)	(TP-61B)	DIFFERENTIAL PRESSURE SWITCH - 50 TO 100 MBTU/H
TP-201	BURNER (125 TO 150 MBTU/H)	(TP-61E)	DIFFERENTIAL PRESSURE SWITCH - 125 & 150 MBTU/H
TP-204	GAS ORIFICE - CONSULT FACTORY	(TP-61D)	DIFFERENTIAL PRESSURE SWITCH - 175 MBTU/H

\*\* 6" TOTAL NEEDED TO COVER OUTER EDGES OF A BURNER BOX







## Kit Contents & Product Features

Kit contents for the DES Series are shown below. Reference the proper column for your particular models length.

FILLED BY:		DES SERIES KIT CONTENTS				
TP#	DESCRIPTION	20 FOOT	30 FOOT	40 FOOT	50 FOOT	60 FOOT
TP-19B	4" Hangers	3	4	5	6	7
TP-21B	4" Tube Clamps	2	3	4	5*	6*
TP-82	4" Refl. Cntr. Sprt.	1	1	1	1	1
TP-105	Reflector End Caps	2	2	2	2	2
IOM	Install / Op Manual	1	1	1	1	1

 4" Hanger TP-19B	 Generic IOM LIOM-GT <i>AND</i> Series Insert LIOM-DES	 4" Reflector Center Support - TP-82	 4" Butt Clamp TP-21B
<b>Notes:</b> *One 4" stainless steel butt clamp is provided for each 175,000 BTU model. Place as shown in IOM.			

## Product Features

### APPROVALS

- CSA/AGA.
- Commercial approval.

### BURNER SIGHT GLASS

- For burner inspection.

### COMBUSTION AIR INLET & VENT

- 4" Duct.

### CONTROLS

- 100% Safety shut off.
- Differential pressure switch.
- Direct spark ignition.
- Flame rod sensing.
- Pre-purge controls.
- Potted circuit board.

### ENAMELED CONTROL BOX

- Outside air collar (4") attached.
- Totally enclosed components.

### EMITTER & COMBUSTION TUBES

- Aluminized combustion chamber (50-125 MBTU/H models).
- Titanium combustion chamber (150-175 MBTU/H models).
- 16ga. 4" O.D. hot-rolled steel radiant tubes.
- Combustion chamber coated with high temperature, corrosion resistant black coating .95 emissivity. Slip fit connection.

### GAS CONNECTION

- 1/2" Male pipe nipple.

### MOUNTING ANGLE

- 0 to 45 degrees from horizontal.

### MOUNTING HEIGHTS MIN. MAX.

- |               |     |     |
|---------------|-----|-----|
| • 50,000 BTU  | 10' | 15' |
| • 60,000 BTU  | 11' | 18' |
| • 75,000 BTU  | 12' | 20' |
| • 100,000 BTU | 13' | 23' |
| • 125,000 BTU | 15' | 25' |
| • 150,000 BTU | 16' | 30' |
| • 175,000 BTU | 17' | 35' |

### WARRANTY

- 1 year-Burner box components.
- 2 years-Combustion and radiant tubes.
- 3 years-Burner.

### OTHER

- One reflector center support per heater.
- Turbulator baffle provided.
- Made in USA.
- Visit [www.reverberray.com](http://www.reverberray.com)