

RVA-2 Series - 4" Tube Heater Installation, Operation, Maintenance and Parts Manual*

Read carefully before attempting to assemble, install, operate or maintain the product described. Protect yourself and others by observing all safety information. Failure to comply with instructions could result in personal injury and/or property damage! Retain instructions for future reference.

*For complete installation instructions, see Generic IOM this piece was accompanied by.

RVA-2 Series

Project: _____ Date: _____
 Location: _____
 City: _____ State: _____ Zip: _____
 Contractor: _____
 Engineer: _____
 Local Representative: _____
 Customer Name: _____
 Address: _____
 City: _____ State: _____ Zip: _____
 Serial #: _____ Phone#: _____
 Date of Installation: _____
 Notes: _____

Table of Contents	
	Page
Models	1
Warnings	2
Clearances to Combustibles	2
Product Summary	3
Product Instructions	3
Heater Requirements	4
Theory of Operation	4
Wiring Diagrams	5-7
Flowchart	8-9
Parts Listing	10-11
Series Kit Contents	12

Models

Qty.	<input type="checkbox"/>	Model #	Gas Type (circle one)	MBTU's	Length	Weight	Suggested Height Above Animals	Combustion Chamber	Radiant Emitter Tube	"Type" Tube Pkg #1	"Type" Tube Pkg. #2	Baffle Pieces	Cert.
		RVA-2 20-65/50**	N or LP	65 / 50	21'-7"	120 #	6' - 9'	409 Stainless	4" Aluminized	20-4 RVA	N/A	5	CSA
		RVA-2 20-75/50	N or LP	75 / 50	21'-7"	120 #	7' - 10'	409 Stainless	4" Aluminized	20-4 RVA	N/A	5	CSA
		RVA-2 30-75/50	N or LP	75 / 50	31'-3"	160 #	7' - 10'	409 Stainless	4" Aluminized	30-4 RVA	N/A	4	CSA
		RVA-2 30-100/65	N or LP	100 / 65	31'-3"	160 #	8' - 14'	409 Stainless	4" Aluminized	30-4 RVA	N/A	5	CSA
		RVA-2 40-75/50	N or LP	75 / 50	40'-11"	190 #	7' - 10'	409 Stainless	4" Aluminized	40-4 RVA	N/A	2	CSA
		RVA-2 40-100/65	N or LP	100 / 65	40'-11"	190 #	7' - 11'	409 Stainless	4" Aluminized	40-4 RVA	N/A	4	CSA
		RVA-2 40-125/95*	N or LP	125 / 95	40'-11"	190 #	9' - 12'	409 Stainless	4" Aluminized	40-4 RVA	N/A	4	CSA
		RVA-2 40-150/100*	N or LP	150 / 100	40'-11"	190 #	10' - 14'	409 Stainless	4" Aluminized	40-4 RVA	N/A	4	CSA
		RVA-2 50-100/65	N or LP	100 / 65	50'-7"	235 #	8' - 11'	409 Stainless	4" Aluminized	40-4 RVA	10-4 Alum	2	CSA
		RVA-2 50-125/95*	N or LP	125 / 95	50'-7"	235 #	9' - 12'	409 Stainless	4" Aluminized	40-4 RVA	10-4 Alum	4	CSA
		RVA-2 50-150/100*	N or LP	150 / 100	50'-7"	235 #	10' - 14'	409 Stainless	4" Aluminized	40-4 RVA	10-4 Alum	4	CSA

* Not recommended for use in a swine application

** Not recommended for use in a dairy or poultry application.

Warranty registration options:

1. Register online at www.reverberray.com/warranty.
2. Fill out this page and fax to Detroit Radiant Products Co.
3. Fill out this page and mail to Detroit Radiant Products Co.



Printed in U.S.A.
 © Detroit Radiant Products Co.
 21400 Hoover Rd., Warren, MI 48089
 T. (810) 756-0950 F. (810) 756-2626
 Form# LIORVA-2-2M-01/01(MWG)



RVA-2 Series

⚠ WARNING!

NOT FOR RESIDENTIAL USE!

Do not use in the home, sleeping quarters, attached garages, etc.

⚠ WARNING!

This heater must be installed and serviced by trained gas installation and service personnel only. Read and understand these instructions thoroughly before attempting to install, operate or service this heater. Failure to comply could result in personal injury, asphyxiation, death, fire, and/or property damage. Retain these instructions for future reference.

⚠ WARNING!

This is not an explosion-proof heater. Where there is the possibility of exposure to flammable vapors, consult the local fire marshal, the fire insurance carrier and other authorities for approval of the proposed installation.

⚠ WARNING!

Failure to comply with the stated clearances to combustibles could result in personal injury, death and/or property damage.

⚠ WARNING!

This heater should be installed so that the minimum clearances to vehicles, as marked on the heater, will be maintained. If vehicle lifts are present, ensure that these clearances will be maintained from the highest raised vehicle.

CLEARANCES TO COMBUSTIBLES (IN.)

MODEL NO.	MOUNTING ANGLE	SIDE		TOP	BELOW	
		FRONT	BEHIND			
RVA-2 (20) - 65/50 [N,P]	0°	9	9	6	60	
	45°	39	8	10	60	
	W/1 side shield	0°	29	8	6	60
	W/2 side shields	0°	9	9	6	30
RVA-2 (20,30,40) - 75/50 [N,P]	0°	7	7	6	30	
	45°	9	9	6	60	
	45°	39	8	10	60	
	W/1 side shield	0°	29	8	6	60
RVA-2 (30,40,50)- 100/65 [N,P]	0°	9	9	6	30	
	45°	9	9	6	66	
	45°	39	8	10	66	
	W/1 side shield	0°	29	8	6	66
RVA-2 (40,50) - 150/100 [N,P]	0°	16	6	6	66	
	45°	16	6	6	66	
	45°	7	7	6	30	
	W/1 side shield	0°	7	7	6	30
RVA-2 (40,50) - 150/100 [N,P]	0°	14	14	6	66	
	45°	14	14	6	66	
	45°	39	8	10	66	
	W/1 side shield	0°	29	8	6	66
RVA-2 (40,50) - 150/100 [N,P]	0°	24	24	6	81	
	45°	24	24	6	81	
	45°	58	8	10	81	
	W/1 side shield	0°	42	8	6	81
RVA-2 (40,50) - 150/100 [N,P]	0°	23	23	6	81	
	45°	23	23	6	81	
	45°	11	11	6	44	

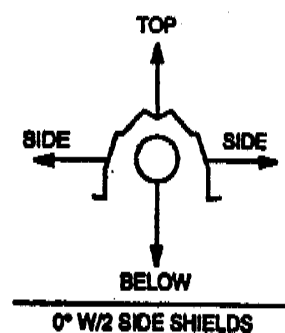
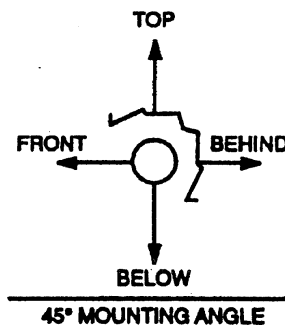
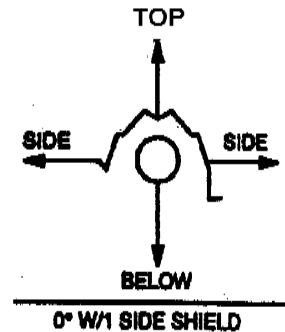
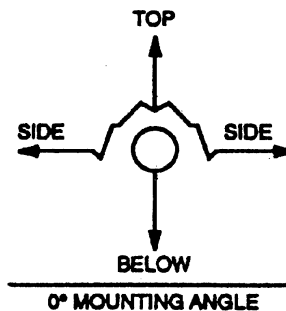

RVA-2 Series Mechanical Instructions















This supplement is designed to address the specifics of the RVA-2 Series. Also see the generic IOM supplied with model.

Product Summary

RVA-2 Series heaters are available from 20 to 50 foot, 50,000 to 150,000 BTU's, natural or LP gas. RVA-2 Series are positive pressure, two-stage heaters and feature aluminized steel for it's radiant pipes.

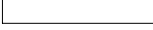
Be sure to identify the stainless steel combustion chamber and place as the first tube section. Also, identify the uncoated aluminized tube and place as the second tube section.

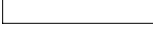
Product Installation

Stainless steel 	Aluminized 			
Stainless steel 	Aluminized 	Black Coated Alum. 		
Stainless steel 	Aluminized 	Black Coated Alum. 	Black Coated Alum. 	
Stainless steel 	Aluminized 	Black Coated Alum. 	Black Coated Alum. 	Black Coated Alum. 

The RVA-2 ALWAYS has a 4" stainless steel combustion chamber (identified by an orange sticker); 4" unpainted aluminized heat exchanger (silver in appearance), following the combustion chamber; and 4" black coated aluminized heat exchanger every tube there after.

Combustion Air

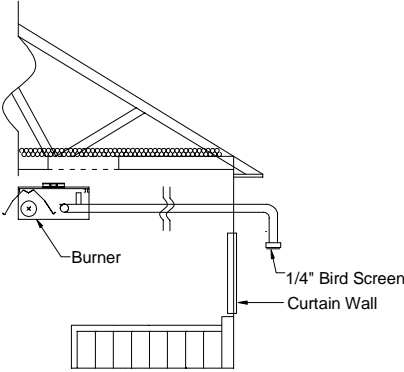

The combustion air intake collar is also a factory-preset air orifice. Non-contaminated air for combustion must be ducted to the heater in all agricultural applications. Do not take combustion air from attic. Locate intake away from any steam source. Use caution when placing intake above curtain walls, as they leak. See adjacent figure. Use light gauge, 4 inch PVC air intake material from curtain sidewall to heater. Do not exceed 25 feet. With elbow, drop below curtain top, one foot in length. Cap with 1/4 inch birdscreen.

Optional Side Shields

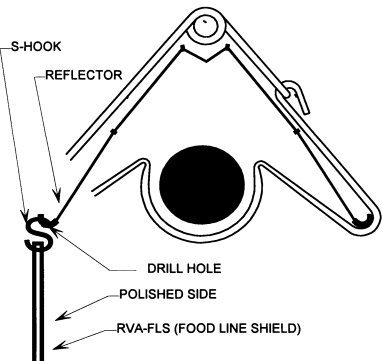

Optional Food Line Shield Installation (FLS)

1. Install optional FLS where needed to protect feeder lines that are within the clearance to combustible zone.
2. It may be necessary to directly shield plastic tubing if it is located within the specified clearance to combustibles zone.



RVA-2 Series

Electrical Requirements

- 120 Volt - 60 Hz GRD, 3-wire.
- 25V thermostat connection.
- Amps Starting - 4.8, Running - 1.1

NOTE: All RVA-2 Series are equipped with a relay board. A 24V supply (from a field supplied 40VA transformer) is necessary. Supply to yellow control cord only. Note 3 wire colors. White - Low Fire, Black - High Fire, Green - Ground.

Black power cord is constant 120V. Observe polarity.

Gas Requirements

- ♦ Manifold Pressure
 - Nat. 3.5" • LP. 10.0"
- ♦ Minimum Inlet Pressure
 - Nat. 5.0" • LP. 11.0"
- ♦ Maximum Inlet
 - Nat. 14.0" • LP. 14.0"

Ventilation Requirements

- ♦ Consult the generic supplement for venting instructions. If desired, sidewall vent only.
- ♦ For unvented operation, there must be a positive air displacement of at least 3.8 CFM per 1000 BTU/H for natural gas or 4.5 CFM per 1000 BTU/H for LP gas. WVE-4 termination cap must also be used.

Combustion Air Requirements

- ♦ Combustion air intake collar is also a factory-preset air orifice. Non-contaminated air for combustion must be ducted to the heater in all agricultural applications. Do not take combustion air from attic. Locate intake away from any steam source. Use caution when placing above curtain walls, as they leak. See figure on page 3.

Theory of Operation

LOW FIRE

♦ Starting Circuit

When the first stage of a two-stage thermostat calls for heat, the fan relay in the circuit control starts the fan. When the fan creates a sufficient positive pressure in the burner control box, the normally open pressure switch closes, initiating the ignitors sequence. The glo-bar is powered and after 45 seconds the main valve opens. Power to the glo-bar is shut off during the last three seconds of the ignition trial.

♦ Running Circuit

After ignition, the flame rod monitors the flame. As long as a flame is present, the valve is held open. If the flame is lost, the control acts to close the valve within one second, and a new trial sequence identical to that at start-up is initiated. If proof of flame is not established within 8.5 seconds, the unit will lock out. If lockout occurs, the control can be reset by briefly interrupting the power source.

HIGH FIRE

The second stage can be energized at any time during the operation causing the heater to operate in the high fire mode. This is accomplished by a solenoid, which pushes down on the regulator increasing the manifold pressure and therefore the BTU/H input of the heater.

Internal Wiring Diagrams

MICRO 60U-24 Single Pressure Switch

WITH HLRB RELAY BOARD

MICRO 60U-24 LADDER DIAGRAM - WITH RELAY BOARD

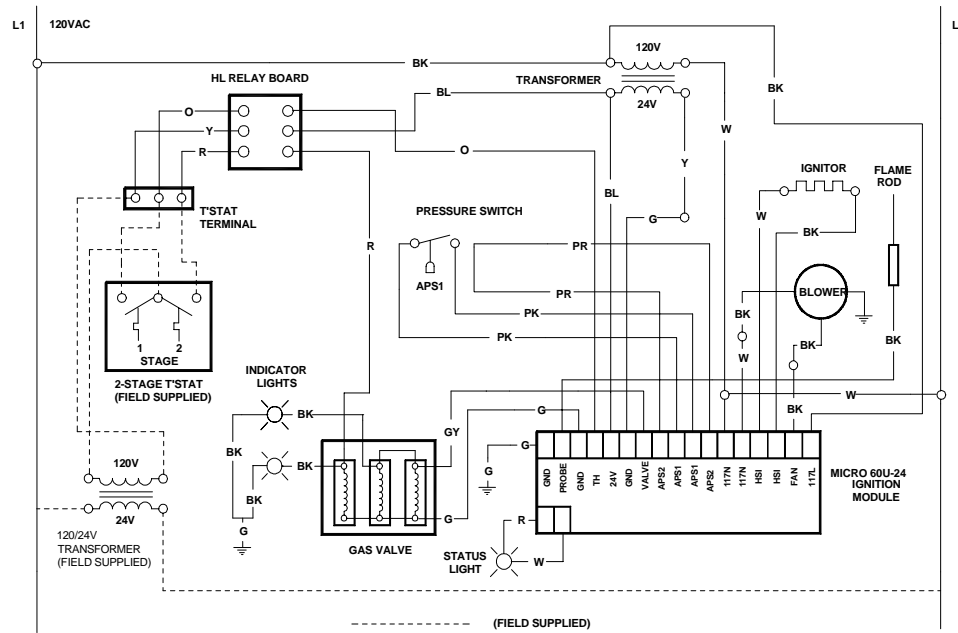

MICRO 60U-24 BLOCK DIAGRAM - WITH RELAY BOARD

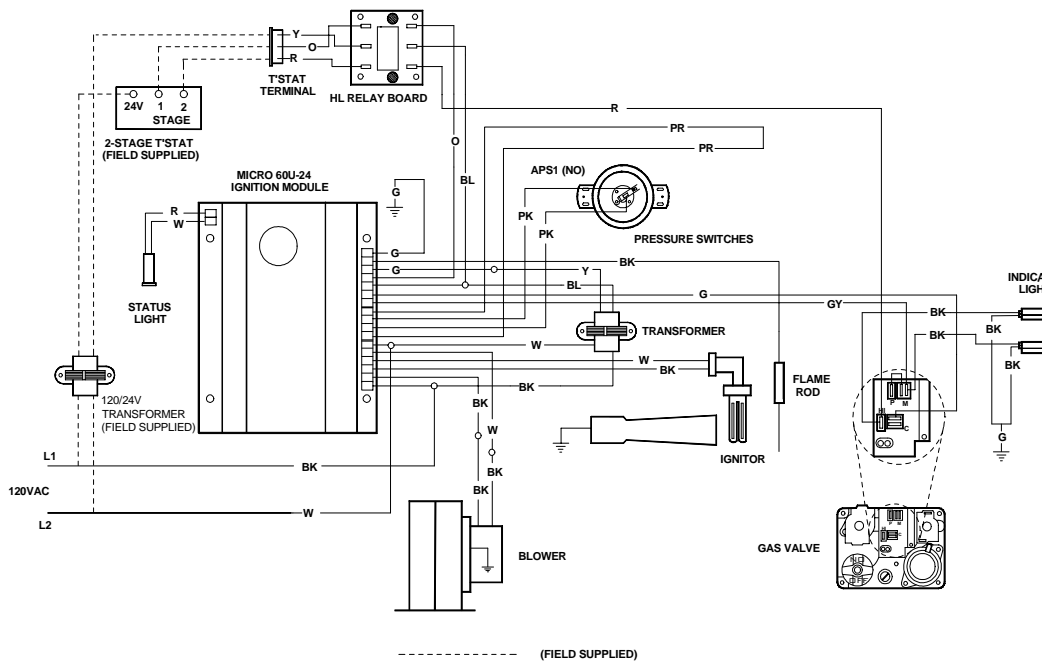

RVA-2 Series

Field Wiring Diagrams

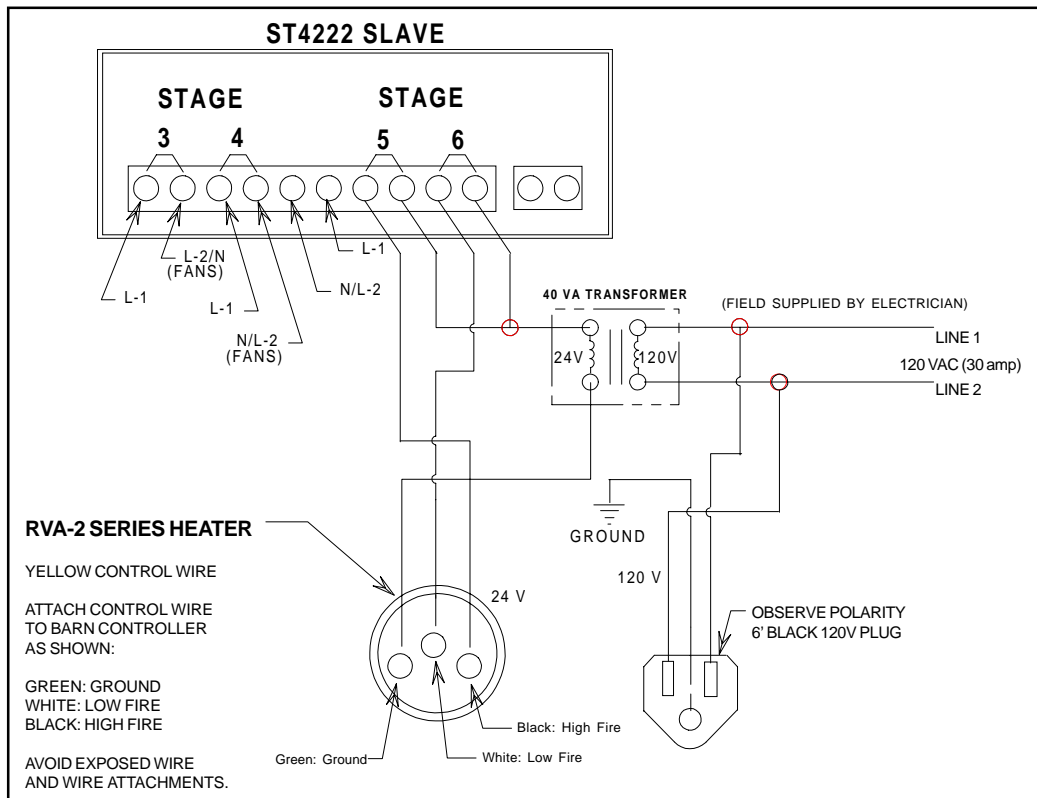

TYPICAL WIRING DIAGRAM TO BARN CONTROLLER

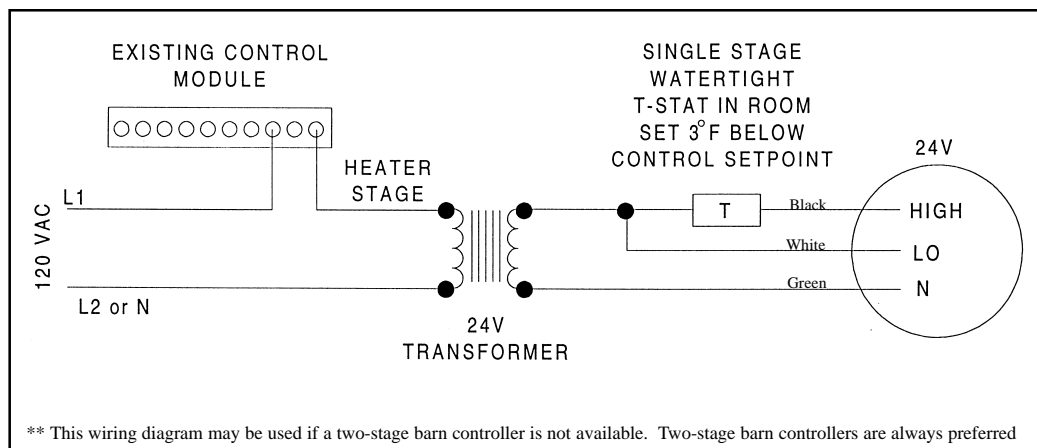

TWO-STAGE CONTROL WIRING WITH SINGLE STAGE BARN CONTROLLER

Electrician: 24V must be field supplied to each unit's yellow cord. Supply 120V to black cord. Observe polarity. Confirm proper two stage electrical wiring by cycling heaters between stages. Proper operation of high fire, low fire and off should be confirmed on all two stage RVA-2 Heaters. RVA-2 model heaters require a 24-volt two-stage thermostat / controller to operate.

Alternative Wiring Diagrams

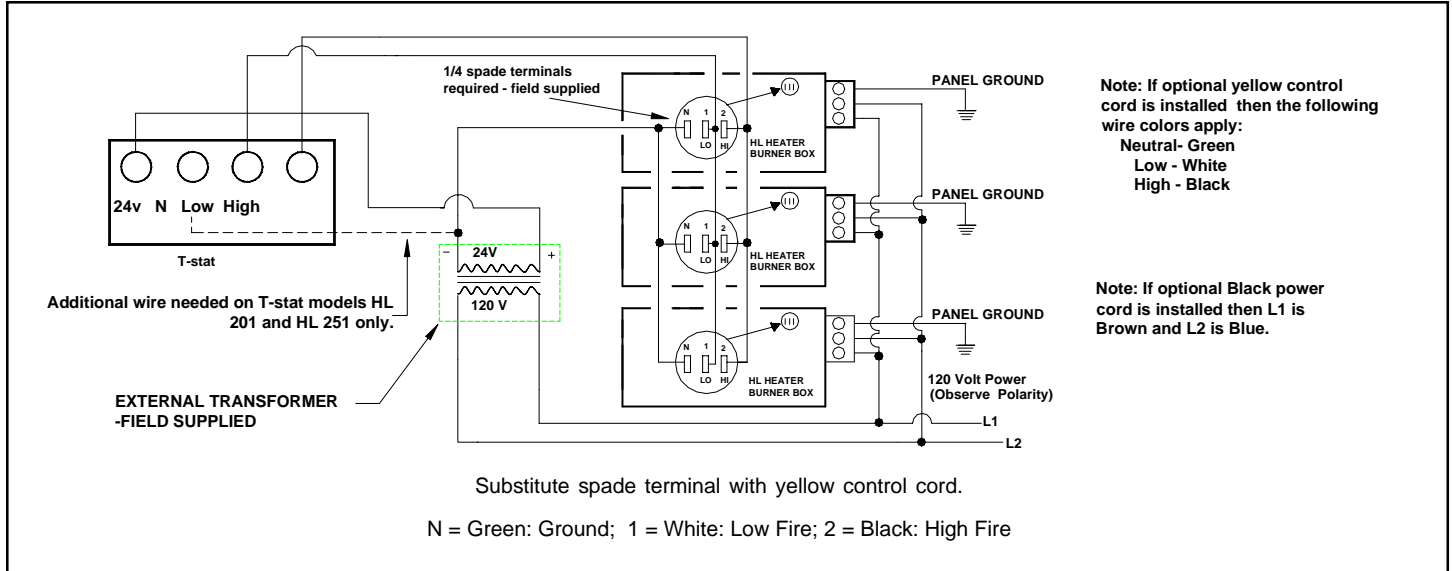

MULTIPLE HEATER CONNECTION

Other

LED CODE	FAULT STATUS	FAULT CODE DELAY
Initial flash on power up, then steady off	Normal operation	Immediate
Steady on	Module failure / Internal fault	Immediate
1 flash	Ignition failure	30-32 minutes
2 flashes	APS 1 failure	10-12 minutes
3 flashes	ASP 2 failure	20-22 minutes
4 flashes	Solenoid valve fault / Leaky valve / Flame amplifier fault	Immediate
No flash on 117V start up	Transformer fault	Immediate

MICRO 60 FAULT CODE DISPLAY CHART



RVA-2 Troubleshooting Flow Chart

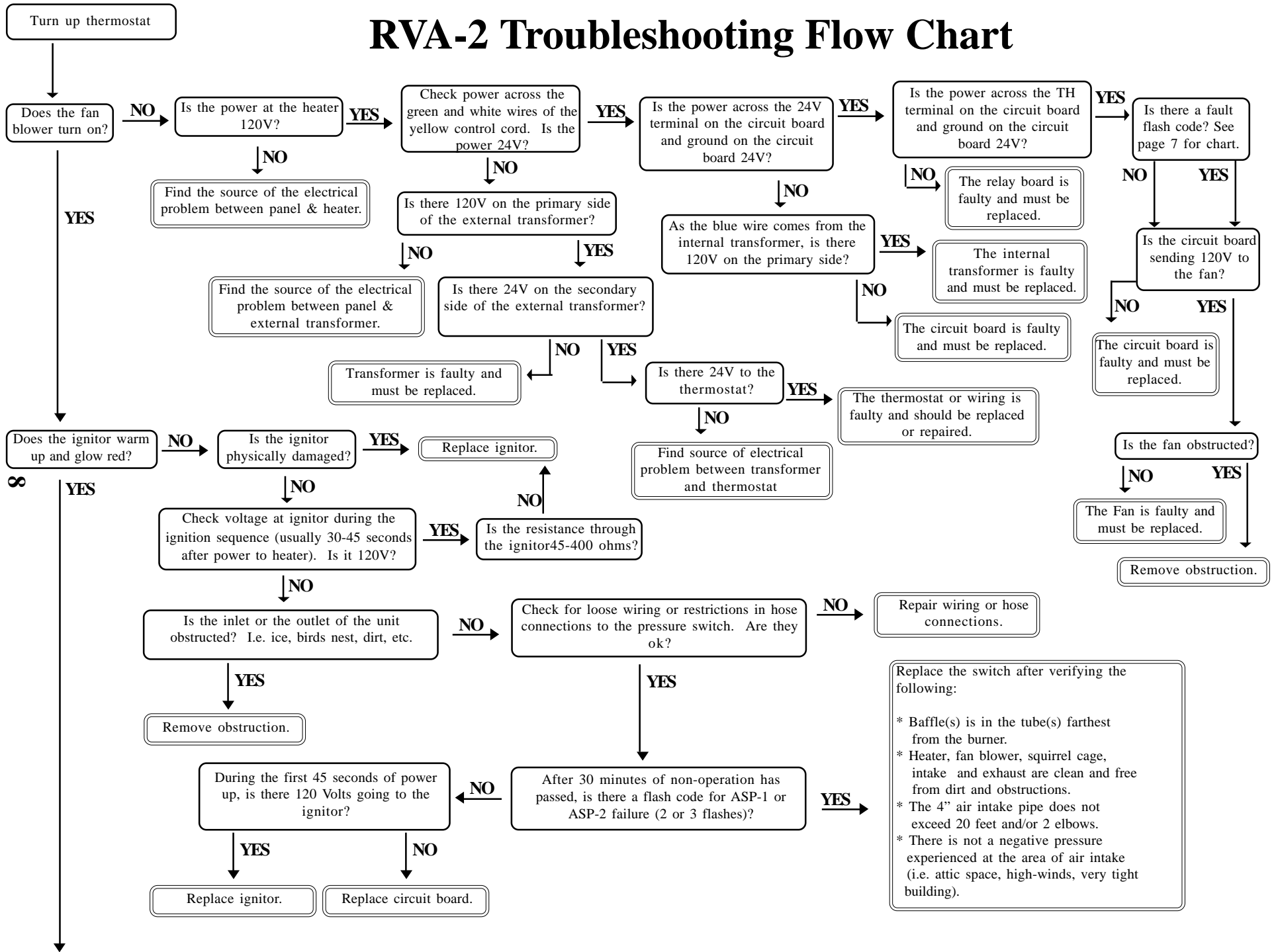

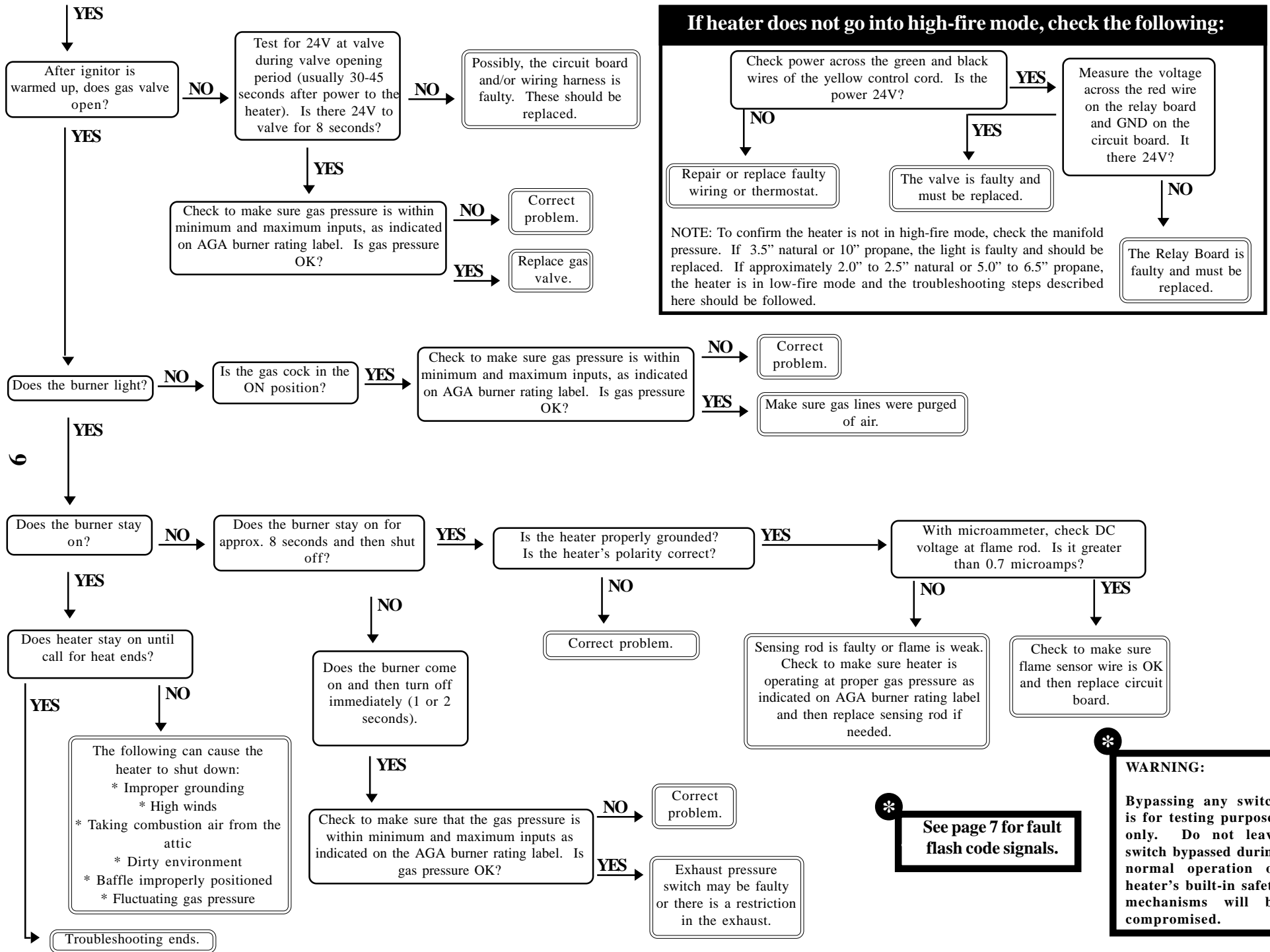

See page 7 for fault flash code signals.

WARNING:
Bypassing any switch is for testing purposes only. Do not leave switch bypassed during normal operation or heater's built-in safety mechanisms will be compromised.

RVA-2 Series

Parts Breakdown

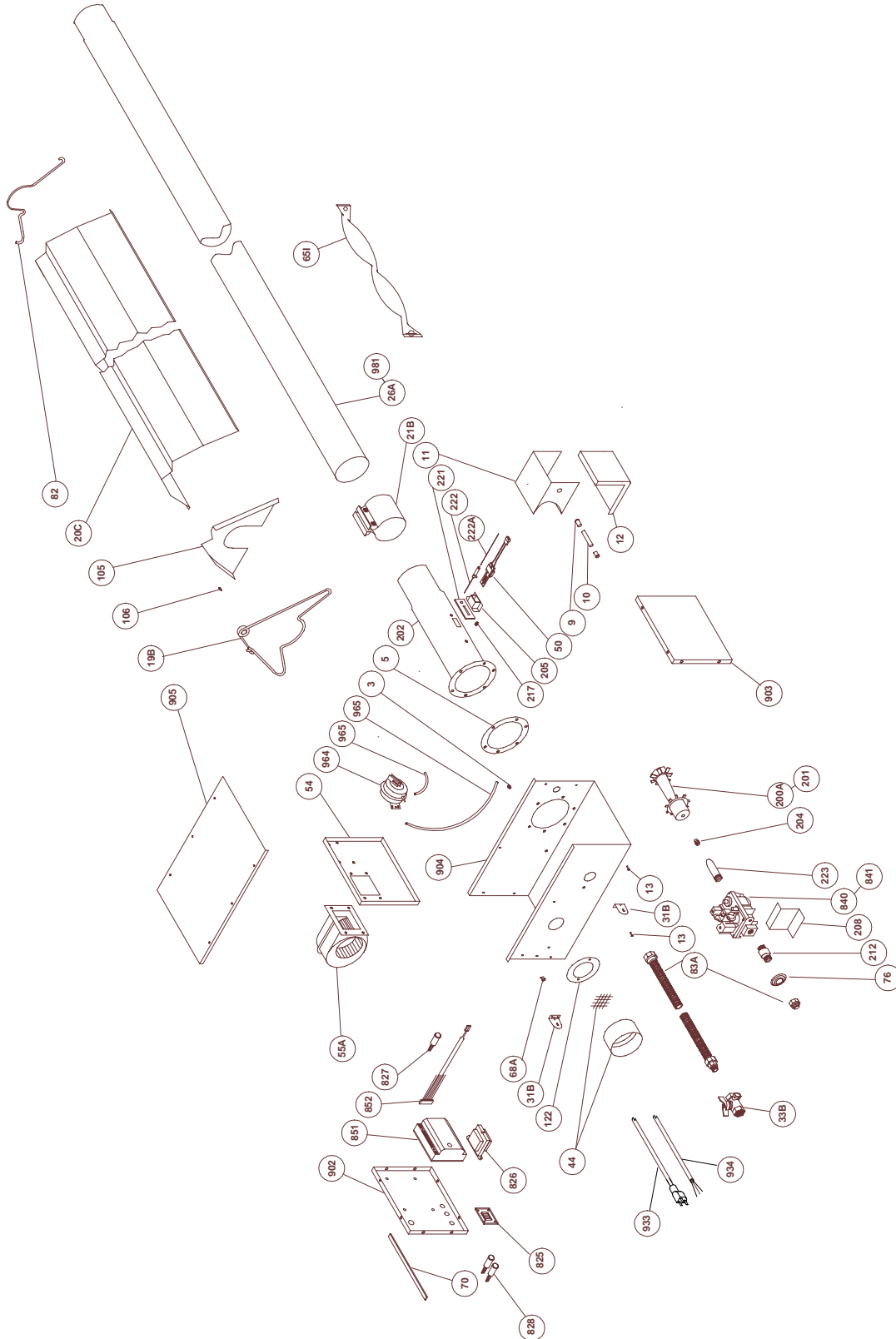



TP#	ITEM	TP#	ITEM
TP-9	CONDUIT COUPLING	TP-200A	SS BURNER (50 TO 100 MBTU/H LP GAS)
TP-10	CONDUIT 4" X 1/2"	TP-201	SS BURNER (150,000 BTU N or LP GAS)
TP-11	IGNITOR BOX	TP-204-SIZE	GAS ORIFICE - CONSULT FACTORY
TP-12	IGNITOR BOX COVER	TP-205	GLO-BAR HOLDER
TP-13	CONTROL BOX SCREWS	TP-208	"Z" MOUNTING BRACKET
TP-14	SIGHT GLASS GASKET	TP-212	1/2" X 3" PIPE NIPPLE
TP-15	SIGHT GLASS	TP-214	GLO-BAR WIRING HARNESS
TP-16	SIGHT GLASS WASHER	TP-217	PRESSURE BARB FITTING
TP-19B	4" TUBE & REFLECTOR HANGER	TP-219	40VA TRANSFORMER
TP-20C	120" REFLECTOR	TP-221	GLO-BAR HOLDER GASKET
TP-21B	4" TUBE CLAMP	TP-222	FLAME ROD
TP-26A	10 FT. RADIANT TUBE STRAIGHT	TP-222A	FLAME ROD WIRE
TP-31B	CONTROL BOX BRACKET	TP-223	GAS MANIFOLD
TP-33B	1/2" GAS COCK	TP-825	HLRB RELAY BOARD
TP-44-SIZE	AIR ORIFICE W/SCREEN (CONSULT FACTORY)	TP-826	40VA TRANSFORMER (OLD TP-219)
TP-50	GLO-BAR IGNITOR	TP-827	RED LED DISPLAY DIAGNOSTIC LIGHT
TP-54	BURNER BOX DIVIDER	TP-828	YELLOW OPERATIONAL IND. LIGHT
TP-55A	FAN BLOWER	TP-840	36E96-224 TWO-STAGE GAS VALVE - NAT (OLD TP-210)
TP-57A	1/4" PRESSURE TUBE	TP-841	36E96-226 TWO-STAGE GAS VALVE - LP (OLD TP-210P)
TP-65I	33" INTERLOCKING BAFFLE	TP-851	MICRO-60-24 DIAGNOSTIC CIRCUIT BOARD
TP-68A	STRAIN RELIEF BUSHING	TP-852	WIRE HARNESS SET (3 PCS.) FOR MICRO 60 BOARD
TP-68B	LARGE STRAIN RELIEF BUSHING (FOR CORDS)	TP-902	END PANEL - LEFT
TP-70	CONTROL BOX COVER GASKET (PER FOOT**)	TP-903	END PANEL - RIGHT
TP-76	RUBBER GROMMET	TP-904	CONTROL BOX
TP-82	4" REFLECTOR CENTER SUPPORT	TP-905	CONTROL BOX COVER
TP-83A-PVC	PVC COATED STAINLESS FLEX CONNECTOR	TP-933	6' BLACK 120V PLUG
TP-105	REFLECTOR END CAP	TP-934	YELLOW 24V CONTROL WIRE
TP-106	REFLECTOR CLIP	TP-964	NORMALLY OPEN DIFFERENTIAL SWITCH
TP-108	5' AL-TI TUBE, PAINTED W/ ONE CLAMP	TP-965	1/4" VINYL ATMOSPHERIC TUBE AND EXHAUST PRESSURE TUBE
TP-111	5' ALUM. TUBE, PAINTED W/ ONE CLAMP	TP-981	409 STAINLESS STEEL RADIANT TUBE
TP-112	5' REFLECTOR		
TP-122	GASKET FOR AIR ORIFICE & AIR COLLAR		
NON RVA-2 PARTS (older RVA model)			
TP-60G	EXHT PRESSURE SWITCH - 50 TO 150 MBTU/H	DB-201NF	4" TO 3" REDUCER FITTING NO FLANGE
TP-61B	BURNER PRESSURE SWITCH - 50 - 100 MBTU/H	DB-204	3" WIRE HANGER
TP-61D	BURNER PRESSURE SWITCH - 150 MBTU/H	DB-205	3" TUBE CLAMP
DB-82A	3" REFLECTOR CENTER SUPPORT	DB-207	10' ALUMINIZED, PAINTED 3" RADIANT TUBE
		TP-211A	MARK 17U-24 CIRCUIT BOARD (REMOTE SENSE)

** 6" NEEDED TO COVER EDGES OF BURNER BOX



Kit Contents & Product Features

Kit contents for the RVA-2 Series are shown below. Reference the proper column for your particular models length.

FILLED BY:		RVA-2 SERIES KIT CONTENTS			
TP#	DESCRIPTION	20 FOOT	30 FOOT	40 FOOT	50 FOOT
TP-19B	4" Hangers	3	4	5	6
TP-21B	4" Tube Clamps	2	3	4	5
TP-33B	1/2" Gas Cock	1	1	1	1
TP-82	4" Refl. Cntr. Sprt.	2	3	4	5
TP-83A	24" SS PVC Flex Line	1	1	1	1
TP-105	Refl. Endcaps	2	2	2	2
TP-106	Refl. Endcap Clips	8	8	8	8
IOM	Install / Op Manual	1	1	1	1

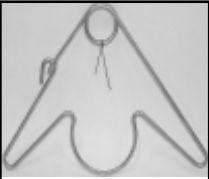

4" Hanger
TP-19B



4" Butt Clamp
TP-21B



Gas Cock
1/2" TP-33B



Bag of Reflector
End Cap Clips.
TP-106



PVC Coated 24" SS Flex
Connect TP-83PVC



Reflector End
Caps TP-105



4" Reflector
Center
Support-
TP-82



Generic IOM
LIOM-Tube
AND
Series Insert
LIOM-RVA-2

Product Features

APPROVALS

- AGA/IAS.
- Commercial approval.
- CSA.

BURNER SIGHT GLASS

- For burner inspection.

COMBUSTION AIR INLET & VENT

- 4" Male duct.

CONTROL BOX

- Outside air collar (4") attached.
- Totally enclosed components.
- 304 stainless steel

CONTROLS

- 100% safety shut off.
- Microprocessor circuit board provides soft lockout and self-diagnostic features.
- Differential pressure switch.
- Silicon carbide hot surface igniter.
- Flame rod sensing.
- Pre and post-purge controls.

EMITTER & COMBUSTION TUBES

- 16ga. 4" O.D. aluminized steel radiant tubes.
- Radiant tubes coated with high temperature, corrosion resistant black coating .95 emissivity. Slip fit connection.
- 409 stainless steel combustion chamber.

GAS CONNECTION

- 1/2" gas cock included.
- Male pipe nipple.
- 1/2" stainless steel PVC flex connector included.

RADIANT SURFACE AREA (SQ. FT.)

- 20' Models – 20.2
- 30' Models – 30.4
- 40' Models – 40.5
- 50' Models – 50.6

WARRANTY

- 1 year - Burner box components.
- 3 years - Combustion and radiant tubes.
- 5 years - Burner.

OTHER

- One reflector center support per tube.
- Turbulator baffle included.
- Made in U.S.A.
- Visit www.reverberray.com for parts information.