



# MP SERIES TUBE HEATERS

## SUBMITTAL DATA – MODULATING LOW INTENSITY GAS-FIRED INFRARED TUBE HEATERS & ACCESSORIES

SUBMITTED BY: \_\_\_\_\_ DATE: \_\_\_\_\_

JOB TITLE: \_\_\_\_\_ CONTRACTOR: \_\_\_\_\_

ADDRESS: \_\_\_\_\_ PHONE #: \_\_\_\_\_

CITY: \_\_\_\_\_ ADDRESS: \_\_\_\_\_

STATE: \_\_\_\_\_ ZIP: \_\_\_\_\_ CITY: \_\_\_\_\_

STATE: \_\_\_\_\_ ZIP: \_\_\_\_\_

ENGINEER: \_\_\_\_\_

LOCAL REPRESENTATIVE: \_\_\_\_\_

NOTES: \_\_\_\_\_

\_\_\_\_\_

\_\_\_\_\_

QTY.	MODEL #	TAG	INDICATE GAS TYPE	BLAST MODE RATE MBH	STANDARD MODULATING RANGE MBH	STRAIGHT LENGTH	U-TUBE LENGTH	STANDARD WEIGHT	TYP. OR RCMD. MOUNTING HEIGHTS <sup>1</sup>
	MP-25-80 <sup>2</sup>		Nat. or Prop.	85	52 - 80	26'- 5"	15'- 3" <sup>3</sup>	145 lbs.	12' to 20'
	MP-30-80 <sup>2</sup>		Nat. or Prop.	85	52 - 80	31'- 5"	17'- 9" <sup>4</sup>	160 lbs.	12' to 20'
	MP-30-115 <sup>2</sup>		Nat. or Prop.	120	75 - 115	31'- 5"	17'- 9" <sup>4</sup>	160 lbs.	14' to 22'
	MP-40-80 <sup>2</sup>		Nat. or Prop.	85	52 - 80	41'- 1"	22'- 9"	190 lbs.	12' to 20'
	MP-40-115 <sup>2</sup>		Nat. or Prop.	120	75 - 115	41'- 1"	22'- 9"	190 lbs.	15' to 25'
	MP-40-150 <sup>2</sup>		Nat. or Prop.	155	97.5 - 150	41'- 1"	22'- 9"	190 lbs.	15' to 28'
	MP-50-115 <sup>2</sup>		Nat. or Prop.	120	75 - 115	50'- 9"	27'- 5" <sup>4</sup>	235 lbs.	15' to 28'
	MP-50-150 <sup>2</sup>		Nat. or Prop.	155	97.5 - 150	50'- 9"	27'- 5" <sup>4</sup>	235 lbs.	17' to 30'
	MP-50-200		Nat. or Prop.	200	130 - 194	50'- 9"	27'- 5" <sup>4</sup>	235 lbs.	19' to 37'
	MP-60-150 <sup>2</sup>		Nat. or Prop.	155	97.5 - 150	60'- 5"	32'- 5"	265 lbs.	17' to 32'
	MP-60-200 <sup>2</sup>		Nat. or Prop.	200	130 - 194	60'- 5"	32'- 5"	265 lbs.	19' to 37'
	MP-70-200 <sup>2</sup>		Nat. or Prop.	200	130 - 194	70' - 1"	37'- 3" <sup>4</sup>	300 lbs.	19' to 42'

<sup>1</sup>Typical or recommended mounting heights are provided as guidelines only. Application, site conditions, desired comfort levels, etc. may require mounting heights outside of these recommendations. Refer to Installation, Operation, and Maintenance Manual for complete installation instructions.

<sup>2</sup>Stainless steel tube upgrade available.

<sup>3</sup>Model requires 2.5EA-SUB accessory package when installing in a 'U' configuration.

<sup>4</sup>Model requires 5EA-SUB accessory package when installing in a 'U' configuration.

### DETROIT RADIANT PRODUCTS CO.

### VISIT OUR WEBSITE FOR:



21400 Hoover Rd.  
Warren, MI 48089-3162

Phone: (586) 756-0950  
Toll Free: 1-800-222-1100  
Fax: (586) 756-2626  
Email: sales@drp-co.com  
Website: www.reverberray.com

- Product Specs
- Parts Support
- Dealer Locator
- Applications
- CAD/Revit Library
- Design Guidelines
- Theory of Infrared
- and More!

# MP SERIES SPECIFICATIONS

## APPROVALS

- CSA Design Certified, ANSI Z83.20b
- Indoor/Outdoor Approval (with OD-Kit)
- Commercial/Industrial Approval

## BURNER CONTROL BOX

- Sight glass for burner inspection
- Totally enclosed components
- Serviceable while in operation
- Coated enameled steel
- Operational indicator lights

## GAS CONNECTION

- 36" x 3/4" S.S. flexible gas connector

## POWER SUPPLY

- 120 VAC, 60 Hz, 3-wire
- 60 in. grounded power cord
- Low voltage thermostat connection
- Ignition current - 4.8 Amps
- Running current - 1.1 Amps

## COMBUSTION AIR INLET & VENTING

- Preset 4" combustion air inlet collar
- Sidewall or roof venting

## GAS PRESSURE (Inches W.C.) Nat Prop

- Manifold @ min. rate 1.65" 4.80"
- Manifold @ max. rate 4.10" 11.0"
- Min. inlet 6.0" 12.0"
- Max. inlet 14.0" 14.0"

## EMITTER & COMBUSTION TUBES

- 16 ga. 4" O.D. aluminized coated steel radiant emitter tubes
- Aluminized (25-115 MBH models) or titanium stabilized combustion chamber (150-200 MBH models)
- All tubes coated with high temperature, corrosion resistant black coating, .95 emissivity
- Slip-fit swaged connection
- Turbulator baffle

## IGNITION/FLAME SENSE

- Hot surface ignition
- Flame rod sense
- Self-diagnostic LED

## INTERNAL CONTROLS

- 100% safety shut-off
- Microprocessor based technology with self-learning control logic

## REFLECTOR

- Highly polished aluminum
- Two end caps included
- Reflector tension springs
- Continuous overlap design
- One reflector center support per reflector

## LIMITED WARRANTY

- 3 Years - Burner box components
- 5 Years - Combustion and radiant tubes
- 10 Years - Internal burner

# CLEARANCES TO COMBUSTIBLES (IN INCHES)

MODEL NO.	MOUNTING ANGLE <sup>5</sup>	SIDE			
		FRONT	BEHIND	TOP	BELOW
MP (25, 30, 40) - 80 [N,P]	0°	14	14	6	66
	45°	39	8	10	66
W/1 side shield	0°	29	8	6	66
W/2 side shields	0°	16	16	6	66
20 ft. from burner	0°	7	7	6	30
MP (30, 40, 50) - 115 [N,P]	0°	20	20	6	76
	45°	58	8	10	76
W/1 side shield	0°	42	8	6	76
W/2 side shields	0°	20	20	6	76
20 ft. from burner	0°	7	7	6	30
MP (40, 50, 60) - 150 [N,P]	0°	24	24	6	83
	45°	58	8	10	83
W/1 side shield	0°	42	8	6	83
W/2 side shields	0°	23	23	6	83
20 ft. from burner	0°	11	11	6	46
MP (50, 60, 70) - 200 [N,P]	0°	41	41	6	100
	45°	63	8	10	100
W/1 side shield	0°	54	8	6	100
W/2 side shields	0°	30	30	6	100
20 ft. from burner	0°	11	11	6	50

<sup>5</sup> Heaters mounted on an angle between 0° and 45° must maintain clearances posted for 0° or 45°, whichever is greater.

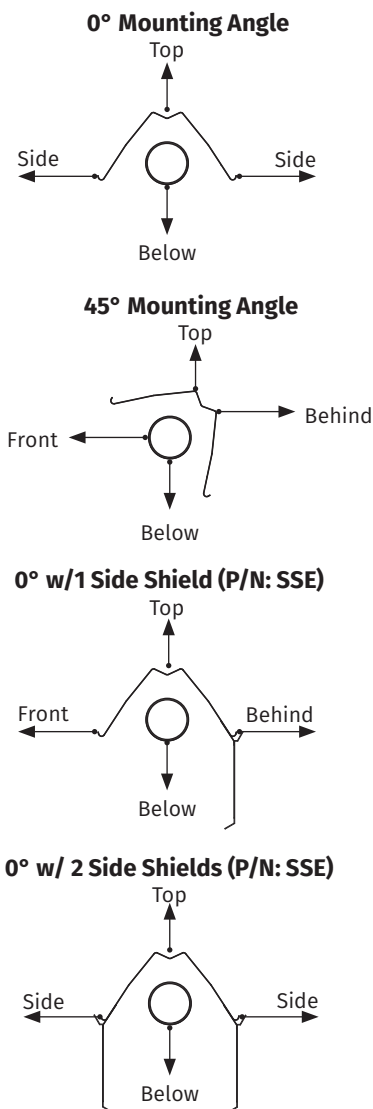

Read and understand the installation, operation, and maintenance manual prior to installing or servicing this unit.

In locations used for the storage of combustible materials, signs must be posted adjacent to the heater's thermostat specifying stacking heights.

# MP SERIES FIELD DATA

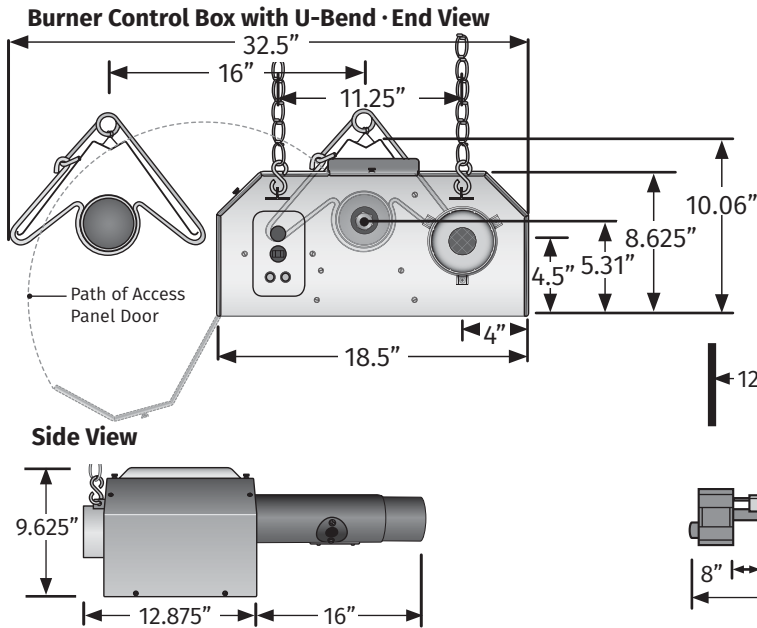

MODEL NUMBER	DIMENSION A STRAIGHT	DIMENSION B U-TUBE
MP-25	26' - 5"	15' - 3" <sup>6</sup>
MP-30	31' - 5"	17' - 9" <sup>7</sup>
MP-40	41' - 1"	22' - 9"
MP-50	50' - 9"	27' - 5" <sup>7</sup>
MP-60	60' - 5"	32' - 5"
MP-70	70' - 1"	37' - 3" <sup>7</sup>

with 2.5EA-SUB<sup>6</sup> or 5EA-SUB<sup>7</sup>

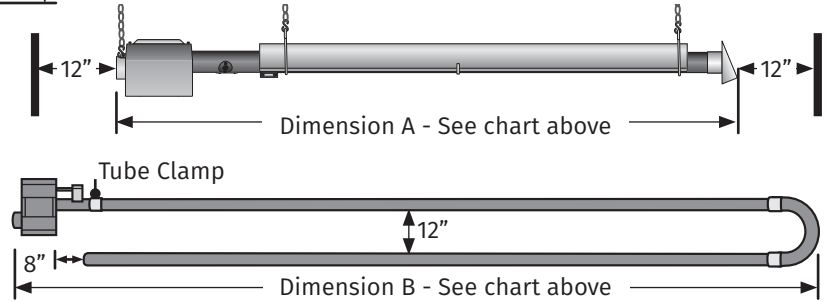

## OPTIONAL ACCESSORIES

QTY.	PART #	DESCRIPTION	NOTES
	2.5EA-SUB	2) 4" Tube & Reflector Halves Substitution	Ideal for making U-shaped heaters from 25 ft. models.
	5EA-SUB	2) 4" Tube & Reflector Halves Substitution	Ideal for making U-shaped heaters from 30, 50, and 70 ft. models.
	10EA	10' x 4" Tube & Reflector Extension	Optional 10 ft. extension package. Maximum of one per unit.
	4-DSK	4" Sidewall Vent Kit	Required for all single sidewall vents. No roof venting.
	6-DSK	6" Sidewall Vent Kit	Required for all common sidewall vents. No roof venting.
	BK	Angle Mounting Bracket 15°-30°-45°	Rotates reflector to preset mounting angles.
	PG	Protective Guard	Protects heat exchanger from contact or objects. Each 5 ft. in length.
	REP	Reflector & Elbow Package	Reflector and accessories used to configure heater in a 'L' shape.
	RTVP-4	4" Rooftop Vent Package	Used to single vent vertically through the roof.
	RTVP-6	6" Rooftop Vent Package	Used to common vent vertically through the roof.
	RUP	Reflector & 'U' Bend Package	Reflector and accessories used to configure heater in a 'U' shape.
	SMB	Single Mount Bracket	Provides units with 'U' bend uniform mounting points. One per 10 ft.
	SSE	Side Shield Extension	Reflector side guard used to lower side clearances. Each 5 ft. in length.
	THCS	Tube Heater Chain Set	5 ft. chain set with two S-hooks used for hanging heater.
	TR60	5' x 4" Tube & Reflector Extension	Optional 5 ft. extension package. Maximum of two per unit.
	WIV-4	4" Combustion Air Intake - Sidewall Cap	Used to duct fresh (cold) air 0-30 ft. to a heater. Sidewall only.
	WVE-GALV	4" Unvented Exhaust Termination Cap	Required on all units when operating unvented.
	Y	4" x 6" x 4" Aluminized Common Vent Fitting	Used for joining two heaters on one vent. Same thermostat required.
	YSM	4" x 6" x 4" Galvanized Common Vent Fitting	Used for joining two heaters on one vent. Same thermostat required.

## CONTROL OPTIONS

QTY.	DESCRIPTION	FEATURES
	<b>Premium User Interface Module (TH-PUI)</b>	Thermostatic control, interactive mode selection, integration with remote sensors.
	<b>Building Management System (BMS)</b>	Used as a control device to allow the heater(s) to be controlled directly by the BMS dictating the heater's firing rate. <sup>8</sup> This control scheme requires the use of the Premium User Interface (TH-PUI) module.
	<b>Single-Stage Thermostat</b>	Used as a control device to allow the user to utilize a desired thermostat that best suits their individual needs. <i>Note: When using a single stage thermostat, it is highly recommended to use the MP-T Remote Temperature Sensor for better performance.</i>
	<b>Thermistor (MP-T)</b>	Recommended for use in conjunction with single stage thermostat to better meet the demands of the space.
	<b>Potentiometer (MP-P)</b>	Used to control the MP series in outdoor or spot heating environments to allow the user to manually control the heater's firing rate based on the dial position.

**NOTE:** Refer to the Tube Heater Accessory List for detailed specifications and limitations on any of the above options.

<sup>8</sup>Device requires heater mode selection by factory or installing contractor.

# WRITTEN SPECIFICATIONS

## PRODUCTS

### 1. TUBULAR INFRARED HEATERS

- A. Basis-of-design product: Subject to compliance with requirements, provide Detroit Radiant Products Company; **Re-Verber-Ray® MP Series.**
- B. Fuel type: Burner shall be designed for [natural] [propane] gas having characteristics same as those of gas available at project site.
- C. Gas and Fan Control: Operation shall allow for full air and gas modulation. Gas modulation shall be CSA Design certified to a minimum turndown of 35% from the maximum operational rate.
  1. The heater controller shall incorporate a forced "Blast Mode" feature (only when used with TH-PUI) to allow the user to temporarily lock the heater into its high input plus an additional 5,000 BTU/h. This feature allows the user to override the normal operation of the heater to address extreme environmental demands for user specified periods of time.
  2. The heater shall have a forced high-fire start-up for faster response to the environmental demand.
  3. The heaters shall operate based on full proportional-integral-derivative (PID) logic to reduce on/off cycles.
  4. Components shall be incorporated to allow the user to select from three performance modes.
    - a. Comfort Mode allows the unit operation to minimize temperature differentials across the length of the heater. It is intended to provide a system that has a greater perceived comfort than the other modes due to more even dissipation of heat.
    - b. Standard Mode allows the unit to operate as a balance between Comfort Mode and Economy Mode. It is intended to provide a system with moderate thermal efficiency while still minimizing the greater temperature differentials associated with Economy Mode.
    - c. Economy Mode allows the unit operation to maximize thermal efficiency. It is designed to provide a system that is more thermally efficient than the other modes due to quicker dissipation of heat.
- D. Combustion Chamber: Shall be 4-inch O.D. 16ga. Titanium stabilized aluminized steel (150-200 MBH to allow for the operating temperature to exceed the 1030°F as set forth in the ANSI Z83.20 standard) or aluminized steel (below 150 MBH), finished with a high emissivity rated, corrosion-resistant, black coating with an emissivity level documented at .92 or higher. A 409 grade stainless steel chamber shall be used when specified for harsher environments.
- E. Emitter Tube: Shall be 4-inch O.D. 16 ga. aluminized steel finished with a high emissivity rated, corrosion-resistant, black coating with an emissivity level documented at .92 or higher. A 304 grade stainless steel emitter tube shall be used when specified for harsher environments.
- F. Appliance Type: Unit shall be a positive pressure power burner with a combustion fan upstream of the burner and exhaust gases for component longevity, maximum combustion efficiency, and energy transfer. Negative pressure (pull through) type appliances will not be allowed.
- G. Combustion Fan: Motor type shall be permanent-split capacitor (PSC) for optimal efficiency and longevity and shall have sealed bearings. Shaded pole motors shall not be permitted.
- H. Fan Enclosure: Combustion fan shall be totally housed inside burner control box and not exposed. Appliances with exposed combustion/exhauster fans shall not be permitted.
- I. Burner: Stainless-steel venturi burner. The flame anchoring screen shall have a minimum temperature rating equivalent to that of 304 grade stainless steel. Non-stainless steel burners shall not be permitted.
- J. Tube Connections: The combustion chamber and radiant emitter tube shall incorporate a 4-inch slip-fit, interlocking connection in which the upstream tube slides into the next tube and is held by a bolted clamp. Connector clamps shall not cover more than 4 inches of exchanger pipe. A butt to butt tube connection system shall not be permitted.
- K. Ignition System: Hot surface silicon carbide (carborundum) capable of temperatures achieving 2400°F. Igniter shall be readily accessible and serviceable without the use of tools. Spark ignition systems shall not be permitted.
- L. Reflectors: Shall be .025 inch polished aluminum with a multi-faceted design which includes reflector end caps. Reflector shall have a polished bright finish with clear visual reflection ability (a sample will be required at time of submittal). Reflector shall have a minimum of seven (7) sheet metal bends in its fabrication to optimize downward radiation. Reflectors shall be rotatable from 0 to 45 degrees when required. The heater's reflector hanging system shall be designed to permit expansion while minimizing noise and/or rattles. Mill finish material shall not be permitted.
- M. Control Box: The exterior control chassis shall be constructed of corrosion resistant enameled steel. A silicone sealed (Sil-Seal) housing shall be used when specified for harsher environments.
  1. The top cover shall be constructed of ABS plastic material.
  2. Air intake: An air intake collar shall be supplied as part of the burner control assembly to accept a 4-inch O.D. supply duct.
  3. The control compartment shall be accessible without the use of tools and serviceable while heater is operating.
  4. Outdoor modifications are required for any application that will be placed in space defined as outdoors. The rating label shall bear the outdoor certification approval.
- N. Heaters shall be equipped with a sight glass allowing a visual inspection of igniter and burner operation from the floor. A sight glass that allows flame viewing only at an appliance level shall not be permitted.
- O. The heaters shall utilize a downstream turbulator baffle for maximum heat transfer.
- P. Heater shall be supplied with a corrugated stainless steel tube (CSST) flexible gas connector.
- Q. Burner Safety Controls:
  1. Heater controls shall include a safety differential pressure switch to monitor combustion air flow, as to provide complete burner shutdown due to insufficient combustion air or flue blockage.
  2. The control system shall be designed to shut off the gas flow to the main burner in the event either a gas supply or power supply interruption occurs.
  3. The blower motor shall be thermally protected and the motor's impeller shall be balanced.
  4. Heater control assembly shall incorporate two indicator lights. One indicator shall validate air flow and the other shall validate gas valve operation.
  5. The air flow control system shall provide a 90 second pre-purge prior to initiating burner operation and a two (2) minute post-purge upon completion, effectively removing all products of combustion from heat exchanger and/or radiant tubes.
  6. No condensation shall form as a result of combustion in the combustion chamber or radiant tubes while at operating temperatures.
- R. Venting: Shall be per the manufacturer's approval and specifications.
- S. Thermostat: Devices and wiring are specified in Division 23 Section "Instrumentation and Control for HVAC." (Select one of the following control schemes)
  1. A smart logic controller that offers the optimal performance out of the modulating heater. It shall modulate the heater(s) with full proportional-integral-derivative (PID) logic considering various inputs and outputs.
  2. A linear 10k ohm potentiometer shall be used as a control device allowing the user to manually control the heater's firing rate based on the dial position. The heater will modulate from the minimum firing rate to the full firing rate.
  3. A single stage programmable thermostat can be used as a control device with the addition of a 10k ohm thermistor thus allowing the heater to modulate based on the temperature rate of changing algorithms.