

# AG2 SERIES TUBE HEATERS

## SUBMITTAL DATA – TWO-STAGE LOW INTENSITY GAS FIRED INFRARED TUBE HEATERS & ACCESSORIES

SUBMITTED BY: \_\_\_\_\_ DATE: \_\_\_\_\_

JOB TITLE: \_\_\_\_\_ CONTRACTOR: \_\_\_\_\_

ADDRESS: \_\_\_\_\_ PHONE #: \_\_\_\_\_

CITY: \_\_\_\_\_ ADDRESS: \_\_\_\_\_

STATE: \_\_\_\_\_ ZIP: \_\_\_\_\_ CITY: \_\_\_\_\_

STATE: \_\_\_\_\_ ZIP: \_\_\_\_\_

ENGINEER: \_\_\_\_\_

LOCAL REPRESENTATIVE: \_\_\_\_\_

NOTES: \_\_\_\_\_

\_\_\_\_\_

\_\_\_\_\_

QTY.	MODEL #	TAG	GAS TYPE (Circle One)	BTU/h High Fire	BTU/h Low Fire	STRAIGHT LENGTH	U-TUBE LENGTH	WEIGHT	RCMD. MOUNTING HEIGHTS <sup>^</sup> Above Animals	FIELD USE ONLY**	
										"TYPE" TUBE PKG #1	"TYPE" TUBE PKG #2
	<b>AG2-20-65</b>		N or LP	65,000	50,000	21' - 7"	13' - 0"	120 lbs.	6' to 9'	20-4 ALUM-HRT-UCC	N/A
	<b>AG2-20-75</b>		N or LP	75,000	50,000	21' - 7"	13' - 0"	120 lbs.	7' to 10'	20-4 ALUM-HRT-UCC	N/A
	<b>AG2-20-80</b>		N or LP	80,000	52,000	21' - 7"	13' - 0"	120 lbs.	8' to 14'	20-4 ALUM-HRT-UCC	N/A
	<b>AG2-30-65</b>		N or LP	65,000	50,000	31' - 3"	*17' - 8"	160 lbs.	6' to 9'	30-4 ALUM-HRT-UCC	N/A
	<b>AG2-30-75</b>		N or LP	75,000	50,000	31' - 3"	*17' - 8"	160 lbs.	7' to 10'	30-4 ALUM-HRT-UCC	N/A
	<b>AG2-30-80</b>		N or LP	80,000	52,000	31' - 3"	*17' - 8"	160 lbs.	8' to 14'	30-4 ALUM-HRT-UCC	N/A
	<b>AG2-30-100</b>		N or LP	100,000	65,000	31' - 3"	*17' - 8"	160 lbs.	8' to 14'	30-4 ALUM-HRT-UCC	N/A
	<b>AG2-40-65</b>		N or LP	65,000	50,000	40' - 11"	22' - 8"	190 lbs.	6' to 9'	40-4 ALUM-HRT-UCC	N/A
	<b>AG2-40-75</b>		N or LP	75,000	50,000	40' - 11"	22' - 8"	190 lbs.	7' to 10'	40-4 ALUM-HRT-UCC	N/A
	<b>AG2-40-80</b>		N or LP	80,000	52,000	40' - 11"	22' - 8"	190 lbs.	8' to 14'	40-4 ALUM-HRT-UCC	N/A
	<b>AG2-40-100</b>		N or LP	100,000	65,000	40' - 11"	22' - 8"	190 lbs.	7' to 11'	40-4 ALUM-HRT-UCC	N/A
	<b>AG2-40-125</b>		N or LP	125,000	95,000	40' - 11"	22' - 8"	190 lbs.	9' to 14'	40-4 ALUM-HRT-UCC	N/A
	<b>AG2-40-150</b>		N or LP	150,000	100,000	40' - 11"	22' - 8"	190 lbs.	10' to 14'	40-4 TITAN-ALUM-HRT-UCC	N/A
	<b>AG2-50-100</b>		N or LP	100,000	65,000	50' - 7"	*27' - 4"	235 lbs.	8' to 11'	40-4 ALUM-HRT-UCC	10-4 HRT
	<b>AG2-50-125</b>		N or LP	125,000	95,000	50' - 7"	*27' - 4"	235 lbs.	9' to 14'	40-4 ALUM-HRT-UCC	10-4 HRT
	<b>AG2-50-150</b>		N or LP	150,000	100,000	50' - 7"	*27' - 4"	235 lbs.	10' to 14'	40-4 TITAN-ALUM-HRT-UCC	10-4 HRT
	<b>AG2-60-150</b>		N or LP	150,000	100,000	60' - 3"	32' - 4"	265 lbs.	10' to 14'	40-4 TITAN-ALUM-HRT-UCC	20-4 HRT

\* Model requires 5EA-SUB accessory package when installing in a 'U' configuration.

\*\* Type packages refer to the tube package that will ship with models (length, diameter, and tube type(s)).

<sup>^</sup> Recommended mounting heights are provided as a guideline. Actual conditions may dictate variations from this data.

**NOTE:** AG2 Series heaters are not recommended for use in swine applications or other harsh environments.

### DETROIT RADIANT PRODUCTS CO.

21400 Hoover Rd.  
Warren, MI 48089-3162  
Phone: (586) 756-0950  
Toll Free: 1-800-222-1100

Fax: (586) 756-2626  
Email: sales@drp-co.com  
Website: www.detroitradiant.com

### VISIT OUR WEBSITE FOR:

- Product Specs
- Parts Support
- Dealer Locator
- Applications
- C.A.D. Library
- Design Guidelines
- Theory of Infrared
- and More!

# AG2 SPECIFICATIONS

## APPROVALS

- CSA Design Certified.
- Indoor/Outdoor Approval.
- Commercial/Industrial Approval.

## WATERTIGHT CONTROL BOX

- Sight glass for burner inspection.
- Totally enclosed components.
- Coated enameled steel.
- Operational indicator lights.

## GAS CONNECTION

- 7/8 in. flare-M FPT connection to 1/2 in. x 24 in. (304) SS PVC coated flex connector provided.
- 1/2" F NPT ball valve & inlet tap included.

## GAS SUPPLY (Inches W.C.)

- Manifold pressure Nat 3.5; LP 10.0
- Min. Inlet pressure Nat 5.0; LP 11.0
- Max. Inlet pressure Nat 14.0; LP 14.0

## POWER SUPPLY

- 120 VAC, 60 Hz GRD, 1 Ph., 3-wire.
- Watertight power cords.
- Ignition current - 4.8 amps.
- Running current - 1.1 amps.

## CONTROLS

- Two-stage gas valve (at 100% and 65%)
- Silicon carbide hot surface ignition.
- Air proving safety switch.
- Pre and post purge controls.
- Flame rod sensing.
- 24V thermostatic control.
- Self-diagnostic - LED "soft lockout".

## REFLECTOR

- Highly polished aluminum.
- Continuous overlap design.
- Two end caps included.
- Anti-rattle tension springs.
- One center support per heater.

## COMBUSTION & RADIANT TUBES

- 16ga. 4" O.D. uncoated titanium stabilized (150 MBH models) or aluminized steel (65-125MBH models) primary combustion chamber.
- 16ga. 4" O.D. uncoated aluminized steel secondary combustion chamber (150 MBH models only).
- 16ga. 4" O.D. uncoated hot-rolled steel radiant emitter tubes.
- Slip-fit swaged tube connection.
- Stainless steel turbulator baffle.

## COMBUSTION AIR INLET & VENTING

- Preset 4 in. combustion air inlet collar.
- Sidewall or roof venting - 4 in. dia. pipe up to 20 ft.

## LIMITED WARRANTY

- 1 year - Burner box components.
- 3 years - Combustion and radiant tubes.
- 5 years - Stainless steel burner.

# CLEARANCES TO COMBUSTIBLES (IN.)

MODEL NO.	MOUNTING ANGLE*	SIDE				
		FRONT	BEHIND	TOP**	BELOW	
AG2 (20, 30, 40) - 65 [N,P]	0°	9	9	6	60	
	45°	39	8	10	60	
	W/1 side shield	0°	29	8	6	60
	W/2 side shields	0°	9	9	6	60
20 ft. from burner	0°	7	7	6	30	
AG2 (20, 30, 40) - 75 [N,P]	0°	9	9	6	60	
	45°	39	8	10	60	
	W/1 side shield	0°	29	8	6	60
	W/2 side shields	0°	9	9	6	60
20 ft. from burner	0°	7	7	6	30	
AG2 (20,30, 40, 50) - (80,100) [N,P]	0°	14	14	6	66	
	45°	39	8	10	66	
	W/1 side shield	0°	29	8	6	66
	W/2 side shields	0°	16	16	6	66
20 ft. from burner	0°	7	7	6	30	
AG2 (40, 50) - 125 [N,P]	0°	20	20	6	76	
	45°	58	8	10	76	
	W/1 side shield	0°	42	8	6	76
	W/2 side shields	0°	20	20	6	76
20 ft. from burner	0°	7	7	6	30	
AG2 (40, 50, 60) - 150 [N,P]	0°	24	24	6	81	
	45°	58	8	10	81	
	W/1 side shield	0°	42	8	6	81
	W/2 side shields	0°	23	23	6	81
20 ft. from burner	0°	11	11	6	44	

\* Heaters mounted on an angle between 0° and 45° must maintain clearances posted for 0° or 45°; whichever is greater.

\*\* Maintain a 10 in. (0° mounting angle) or 12 in. (1-45° mounting angle) clearance from ceilings constructed of tri-ply plastic or plastic fogger lines.

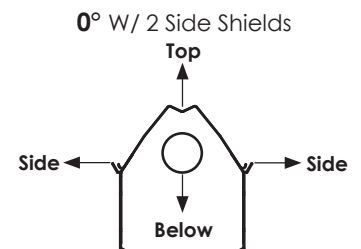
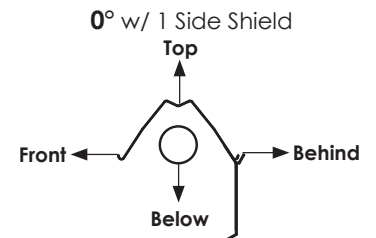
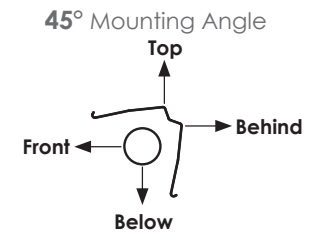
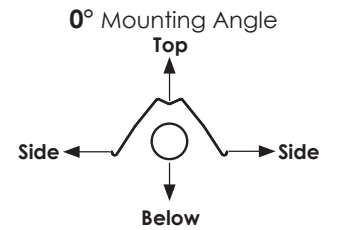

Read and understand the installation, operation and maintenance manual prior to installing or servicing this unit.

In locations used for the storage of combustible materials, signs must be posted adjacent to the heater's thermostat specifying stacking heights.

# FIELD DATA

## Burner Control Box with U-Bend • End View

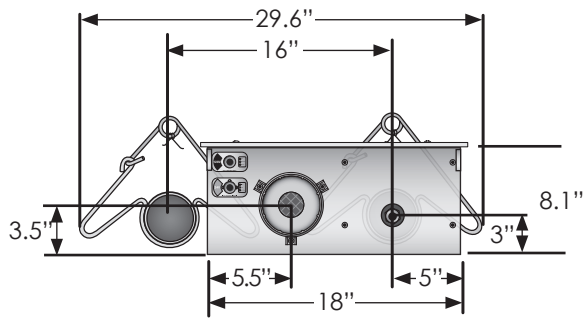

## Side View

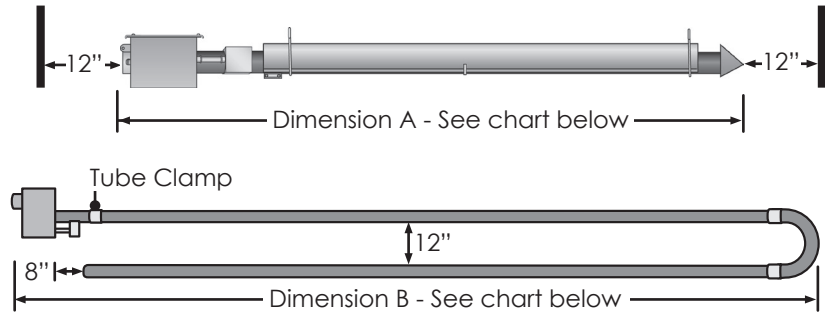
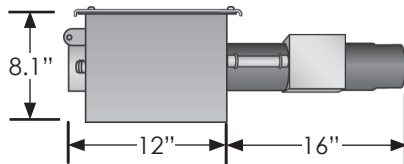

MODEL NUMBER	DIMENSION A STRAIGHT	DIMENSION B U-TUBE
AG2-20	21' - 7"	13' - 0"
AG2-30	31' - 3"	*17' - 8"
AG2-40	40' - 11"	22' - 8"
AG2-50	50' - 7"	*27' - 4"
AG2-60	60' - 3"	32' - 4"

\*with 5EA-SUB

# OPTIONAL ACCESSORIES

QTY.	PART #	DESCRIPTION	NOTES
	10EA	10' X 4" Tube & Reflector Extension	Optional 10 ft. extension package. Maximum of one per unit.
	4-DSK	4" Sidewall Vent Kit	Required for all single sidewall vents. No roof venting.
	6-DSK	6" Sidewall Vent Kit	Required for all common sidewall vents. No roof venting.
	BK	Angle Mounting Bracket 15-30-45 Deg.	Rotates reflector to preset mounting angles.
	E6	90 Degree, 4" Radiant Elbow	Used for making a L-shaped heater. Maximum of two per unit.
	PG	Protective Guard	Protects heat exchanger from contact or objects. Each 5 ft. in length.
	PLQ	Warning Plaque	Hung below heater, restates the clearance to combustibles warning.
	REP	Reflector & Elbow Package	Reflector and accessories used to configure heater in a 'L' shape.
	RTVP-4	4" Rooftop Vent Package	Used to single vent vertically through the roof.
	RTVP-6	6" Rooftop Vent Package	Used to common vent vertically through the roof.
	RUP	Reflector & 'U' Bend Package	Reflector and accessories used to configure heater in a 'U' shape.
	SMB	Single Mount Bracket	Provides units with 'U' bend uniform mounting points. One per 10 ft.
	SSE	Side Shield Extension	Reflector side guard used to lower side clearances. Each 5 ft. in length.
	TF1B	180 Degree, 4" Radiant 'U' Bend	Used for making a U-shaped heater. Maximum of one per unit.
	THCS	Tube Heater Chain Set	5 ft. chain set with two S-hooks used for hanging heater.
	TR60	5'x4" Tube & Reflector Extension	Optional 5 ft. extension package. Maximum of two per unit.
	WIV-4	4" Combustion Air Intake - Sidewall Cap	Used to duct fresh (cold) air 0-30 ft. to a heater. Sidewall only.
	WVE-GALV	4" Unvented Exhaust Termination Cap	Required on all units when operating unvented.
	Y	4"x6"x4" Aluminized Common Vent Fitting	Used for joining two heaters on one vent. Same thermostat required.
	YSM	4"x6"x4" Galvanized Common Vent Fitting	Used for joining two heaters on one vent. Same thermostat required.

## OPTIONAL UPGRADES

- AG-19EAO** Elongated AG wire hanger for wider throw patterns.
- 5EA-SUB** Substitute one 10' radiant tube and reflector for two 5' pieces. Ideal for making "U" heaters from 30', 50' and 70' models. Maximum of one per heater.
- ALUM-AO** Upgrade hot-rolled steel (HRT) radiant tubes to 16 gauge, black coated, aluminized steel for maximum efficiency and longevity. Highly recommended in contaminated or moisture laden environments.
- AGAO-SS** 304 Series stainless steel burner control box.

## STAINLESS STEEL UPGRADES

- SSRAO** 304 stainless steel reflectors.
- SSB-##** Stainless steel mounting brackets. (## = heater length)

## EXTENDED WARRANTIES

- CWO** \_\_\_ year extended controls warranty (max. 4 year).
- EWO** \_\_\_ year extended exchanger warranty (max. 5 year).

**NOTE:** Refer to the Agricultural Series Heater Accessory List for detailed specifications and limitations on any of the above options.

# WRITTEN SPECIFICATIONS

## PRODUCTS

### 1. TUBULAR INFRARED HEATERS

- A. Basis-of-design product: Subject to compliance with requirements, provide Detroit Radiant Products Company; Re-Verber-Ray AG2 Series.
- B. Fuel type: Burner shall be designed for [natural] [propane] gas having characteristics same as those of gas available at project site.
- C. Gas control: Operation shall include a defined input differential. Heater must be CSA Design Certified to operate at an input differential of at least 30% between the low and nominal rated input modes.
  1. The heater's control system shall be designed to shut off the gas flow to the main burner in the event either a gas supply or power supply interruption occurs.
- D. Primary combustion chamber: shall be 4 inch O.D. 16ga. Titanium stabilized aluminized steel (150MBH to allow for the operating temperature to exceed the 1030F as set forth in the ANSI Z83.20 standard) or aluminized steel (below 150 MBH).
- E. Secondary combustion chamber: shall be 4 inch O.D. 16ga. aluminized steel (150MBH models only).
- F. Emitter tube: shall be 4 inch O.D. 16ga. hot rolled steel.
- G. Burner type: Unit shall be a positive pressure power burner with a combustion fan upstream of the burner and exhaust gases for component longevity, maximum combustion efficiency, and energy transfer. Negative pressure (pull through) type appliances will not be allowed.
- H. Fan enclosure: Combustion fan shall be totally housed inside burner control box and not exposed. Appliances with exposed combustion/exhauster fans shall not be permitted.
- I. Burner: Stainless-steel venturi burner. The flame anchoring screen shall have a minimum temperature rating equivalent to 304 grade stainless steel. Non stainless steel burners shall not be permitted.
- J. Tube connections: The heater's combustion chamber and radiant emitter tube shall incorporate a 4 inch slip-fit, interlocking connection in which the upstream tube slides into the next tube and is held by a bolted clamp. A butted tube connection system shall not be permitted.
- K. Ignition system: Hot surface silicon carbide capable of temperatures achieving 2400 F. Igniter shall be readily accessible and serviceable without the use of tools. Spark ignition systems shall not be permitted.
- L. Reflectors: Shall be .025 polished aluminum with a multi-faceted design which includes reflector end caps. Reflector shall have a polished bright finish with clear visual reflection ability. (A sample will be required at time of submittal). Reflector shall have a minimum of 7 sheet metal bends in its fabrication to optimize downward radiation. Reflectors shall be rotatable from 0 to 45 degrees when required. The heater's reflector hanging system shall be designed to permit expansion while minimizing noise and/or rattles.
- M. Control box: Heater's exterior control chassis shall be constructed of corrosion resistant enameled steel and sealed with a high temperature sealant capable of withstanding temperatures up to 500°F.
  1. Air intake: An air intake collar shall be supplied as part of the burner control assembly to accept a 4 inch O.D. supply duct.
  2. The heater's control compartment shall be easily serviceable by removing one (1) panel.
- N. Heaters shall be equipped with a sight glass allowing a visual inspection of igniter and burner operation from the floor. Sight glass visible only at appliance level shall not be permitted.
- O. The heaters shall utilize a downstream turbulator baffle for maximum heat transfer.
- P. Heater shall be supplied with a stainless steel flexible gas connector.
- Q. Burner Safety Controls:
  1. Heater controls shall include a safety differential pressure switch to monitor combustion air flow, as to provide complete burner shutdown due to insufficient combustion air or flue blockage.
  2. The heater's control system shall be designed to shut off the gas flow to the main burner in the event either a gas supply or power supply interruption occurs.
  3. The heater's blower motor shall be thermally protected and the motor's impeller shall be balanced.
  4. Heater control assembly shall include three indicator lights that define the units operating input ranges. One indicator shall validate air flow. Two indicator lights shall indicate low and high stages.
  5. The heater's air flow control system shall provide a 45 second pre-purge prior to initiating burner operation and a 120 second post-purge upon completion, effectively removing all products of combustion from heat exchanger and/or radiant tubes..
  6. No condensation shall form as a result of combustion in the combustion chamber or radiant tubes while at operating temperatures.
  7. Thermostat control shall be two-stage operating on 24 volts.
- R. Venting: shall be per manufacturer approval and specifications.
- S. Thermostat: Devices and wiring are specified in Division 23 Section "Instrumentation and Control for HVAC."
  1. Thermostat: 2-stage, digital programmable wall-mounting type with 50 to 90 deg F (10 to 32 deg C) operating range.
  2. Control Transformer: Integrally mounted.