

DETROIT RADIANT PRODUCTS CO.

Wiring Diagram for Suffix NSP-4 25V and 120V

(Pilot Sensing Element - SPDT Mercury Element)

TYPICAL WIRING SCHEMATIC

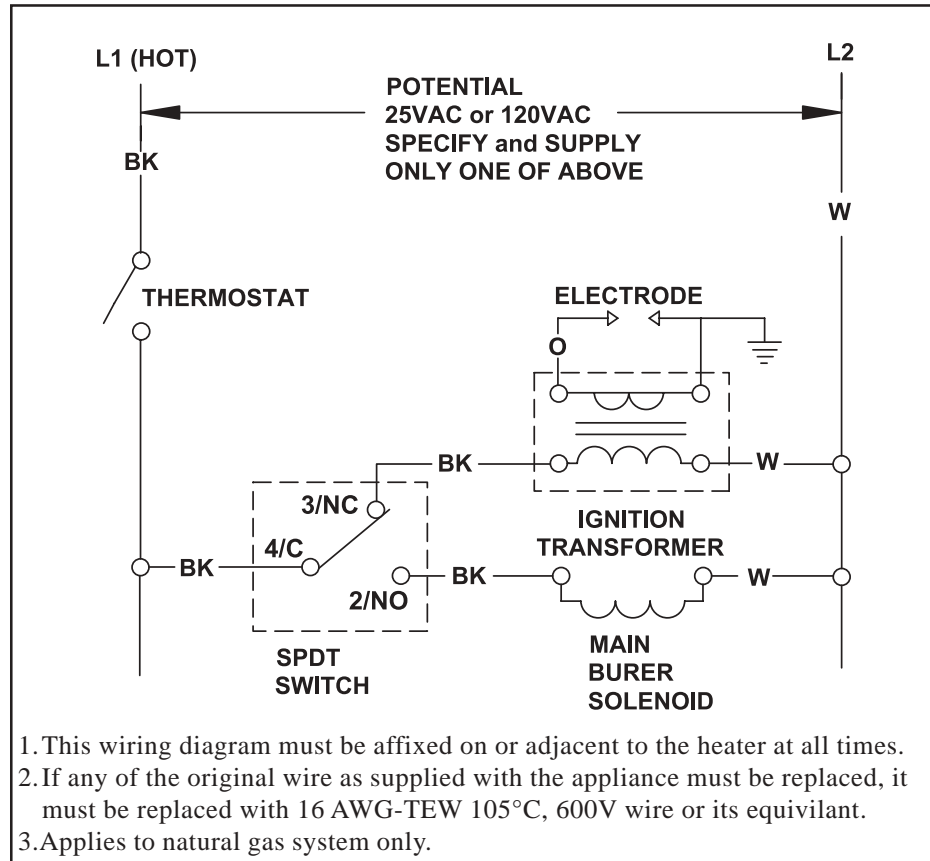

TYPICAL BLOCK DIAGRAM

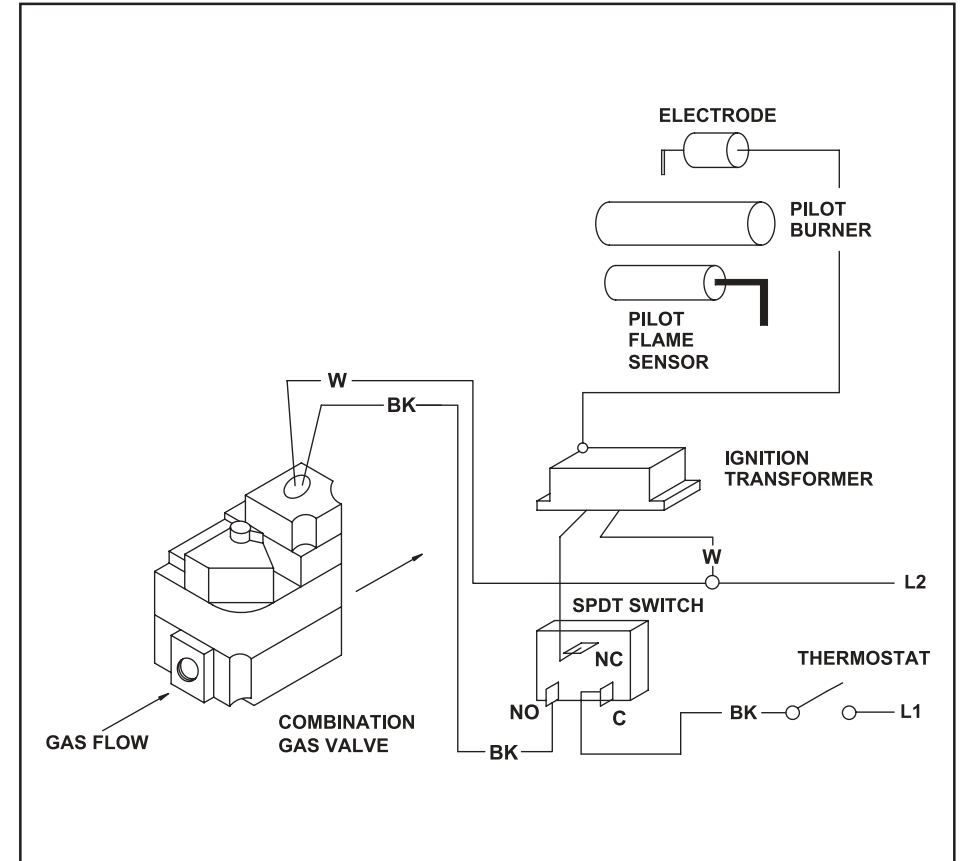

DETROIT RADIANT PRODUCTS CO.

Wiring Diagram for Suffix NSP-4 25V and 120V

(Pilot Sensing Element - SPDT Mercury Element)

Normal Sequence of Operation

Closing of the electrical circuit, upon demand for heat, the following occurs:

1. The systems capacitor discharge ignition transformer is energized, generating a spark at the pilot burner electrode assembly.
2. The pilot burner gas is ignited and a subsequent heating of the pilot sensing element, a mercury single-pole, double-throw pilot switch, occurs.
3. Upon adequate heating, the pilot sensing element switches from its normally closed position - causing the system's capacitor discharge ignition transformer to be de-energized.
4. The heater's main burner solenoid valve is enlarged and opened, resulting in the operation of the heater.



Printed in U.S.A.
© 2006 Detroit Radiant Products Co.
21400 Hoover Rd., Warren, MI 48089
T. (586) 756-0950 F. (586) 756-2626
www.detroitradiant.com
Form# A10-58C-12/05 (DRP)

Production Period
1976-1993