



# DES3 SERIES TUBE HEATERS

## SUBMITTAL DATA – SINGLE STAGE LOW INTENSITY GAS-FIRED INFRARED TUBE HEATERS & ACCESSORIES

SUBMITTED BY: \_\_\_\_\_ DATE: \_\_\_\_\_

JOB TITLE: \_\_\_\_\_ CONTRACTOR: \_\_\_\_\_

ADDRESS: \_\_\_\_\_ PHONE #: \_\_\_\_\_

CITY: \_\_\_\_\_ ADDRESS: \_\_\_\_\_

STATE: \_\_\_\_\_ ZIP: \_\_\_\_\_ CITY: \_\_\_\_\_

STATE: \_\_\_\_\_ ZIP: \_\_\_\_\_

ENGINEER: \_\_\_\_\_

LOCAL REPRESENTATIVE: \_\_\_\_\_

NOTES: \_\_\_\_\_

\_\_\_\_\_

\_\_\_\_\_

QTY.	MODEL #	TAG	INDICATE GAS TYPE	BTU/h INPUT	STRAIGHT LENGTH	U-TUBE LENGTH	STANDARD WEIGHT	TYP. or RCMD. MOUNTING HEIGHTS <sup>1</sup>
	DES3-20-50		N or P	50,000	21'- 9"	13'- 1"	120 lbs.	9' to 14'
	DES3-20-60		N or P	60,000	21'- 9"	13'- 1"	120 lbs.	10' to 15'
	DES3-20-75		N or P	75,000	21'- 9"	13'- 1"	120 lbs.	11' to 18'
	DES3-30-50		N or P	50,000	31'- 5"	17'-9" <sup>2</sup>	160 lbs.	10' to 15'
	DES3-30-60		N or P	60,000	31'- 5"	17'-9" <sup>2</sup>	160 lbs.	11' to 18'
	DES3-30-75		N or P	75,000	31'- 5"	17'-9" <sup>2</sup>	160 lbs.	12' to 20'
	DES3-30-100		N or P	100,000	31'- 5"	17'-9" <sup>2</sup>	160 lbs.	13' to 23'
	DES3-30-125		N or P	125,000	31'- 5"	17'-9" <sup>2</sup>	160 lbs.	14' to 25'
	DES3-40-50		N or P	50,000	41'- 1"	22'- 9"	190 lbs.	11' to 18'
	DES3-40-60		N or P	60,000	41'- 1"	22'- 9"	190 lbs.	11' to 18'
	DES3-40-75		N or P	75,000	41'- 1"	22'- 9"	190 lbs.	12' to 20'
	DES3-40-100		N or P	100,000	41'- 1"	22'- 9"	190 lbs.	13' to 23'
	DES3-40-125		N or P	125,000	41'- 1"	22'- 9"	190 lbs.	14' to 25'
	DES3-40-150		N or P	150,000	41'- 1"	22'- 9"	190 lbs.	15' to 27'
	DES3-40-175		N or P	175,000	41'- 1"	22'- 9"	190 lbs.	17' to 35'
	DES3-50-100		N or P	100,000	50'- 9"	27'- 5" <sup>2</sup>	235 lbs.	15' to 27'
	DES3-50-125		N or P	125,000	50'- 9"	27'- 5" <sup>2</sup>	235 lbs.	15' to 27'
	DES3-50-150		N or P	150,000	50'- 9"	27'- 5" <sup>2</sup>	235 lbs.	16' to 30'
	DES3-50-175		N or P	175,000	50'- 9"	27'- 5" <sup>2</sup>	235 lbs.	17' to 35'
	DES3-50-200		N or P	200,000	50'- 9"	27'- 5" <sup>2</sup>	235 lbs.	18' to 40'
	DES3-60-125		N or P	125,000	60'- 5"	32'- 5"	265 lbs.	16' to 30'
	DES3-60-150		N or P	150,000	60'- 5"	32'- 5"	265 lbs.	17' to 35'
	DES3-60-175		N or P	175,000	60'- 5"	32'- 5"	265 lbs.	17' to 35'
	DES3-60-200		N or P	200,000	60'- 5"	32'- 5"	265 lbs.	18' to 40'
	DES3-70-175		N or P	175,000	70'-1"	37'-3" <sup>2</sup>	300 lbs.	19' to 42'
	DES3-70-200		N or P	200,000	70'-1"	37'-3" <sup>2</sup>	300 lbs.	19' to 42'
	DES3-80-200		N or P	200,000	79'-9"	42'-1"	330 lbs.	20' to 45'

<sup>1</sup> Typical or recommended mounting heights are provided as a guideline. Actual conditions may dictate variations from this data.  
<sup>2</sup> Model requires 5EA-SUB accessory package when installing heater in a U-shaped configuration.

<b>DETROIT RADIANT PRODUCTS CO.</b>		<b>VISIT OUR WEBSITE FOR:</b>	
	21400 Hoover Rd. Warren, MI 48089-3162	Phone: (586) 756-0950 Toll Free: (800) 222-1100 Fax: (586) 756-2626 Email: sales@drp-co.com Website: www.reverberray.com	<ul style="list-style-type: none"> <li style="width: 50%;">• Product Specs</li> <li style="width: 50%;">• CAD/Revit Library</li> <li style="width: 50%;">• Parts Support</li> <li style="width: 50%;">• Design Guidelines</li> <li style="width: 50%;">• Dealer Locator</li> <li style="width: 50%;">• Theory of Infrared</li> <li style="width: 50%;">• Applications</li> <li style="width: 50%;">• and More!</li> </ul>

# DES3 SPECIFICATIONS

## APPROVALS

- CSA Design Certified
- Commercial/Industrial Approval

## BURNER CONTROL BOX

- Sight glass for burner inspection
- Totally enclosed components
- Serviceable while in operation
- Coated enameled steel

## GAS CONNECTION

- 7/8 in. flare-M FPT connection to 1/2 in. x 24 in (304) SS flex connector provided

## GAS SUPPLY (Inches W.C.)

- Manifold pressure: Nat 3.5; Prop 10.0
- Min. inlet pressure: Nat 5.0; Prop 11.0
- Max. inlet pressure: Nat 14.0; Prop 14.0

## POWER SUPPLY

- 120 VAC, 60 Hz GRD, 1 Ph., 3-wire
- 60 in. grounded power cord
- Ignition current - 1.7 amps
- Running current - 1.1 amps

## CONTROLS

- Air proving safety switch
- Direct spark ignition
- Pre-purge controls
- Flame rod sensing
- 120 V thermostatic control
- Moisture and corrosion resistant ignition module

## REFLECTOR

- Highly polished aluminum
- Continuous overlap design
- One reflector center support per heater

## COMBUSTION & RADIANT TUBES

- 16 gauge, 4 in. O.D. hot-rolled steel radiant emitter tube(s)
- Coated aluminized or Titanium treated primary combustion chamber (150-200 MBH models)
- Coated aluminized secondary combustion chamber (150-200 MBH models)
- Slip-fit swaged tube connection
- Turbulator baffle

## COMBUSTION AIR INLET & VENTING

- Preset 4 in. combustion air inlet collar
- Sidewall or roof venting

## LIMITED WARRANTY

- 1 year - Burner box components
- 3 years - Combustion and radiant tubes
- 5 years - Burner

# DES3 CLEARANCES TO COMBUSTIBLES (IN INCHES)

MODEL NO.	MOUNTING ANGLE <sup>3</sup>	SIDE			
		FRONT	BEHIND	TOP	BELOW
DES3 (20, 30, 40) - 50, 60 [N,P]	0°	9	9	6	47
	45°	39	8	10	47
w/1 side shield	0°	29	8	6	47
w/2 side shields	0°	9	9	6	47
20 ft. from burner	0°	7	7	6	30
DES3 (20, 30, 40) - 75 [N,P]	0°	9	9	6	60
	45°	39	8	10	60
w/1 side shield	0°	29	8	6	60
w/2 side shields	0°	9	9	6	60
20 ft. from burner	0°	7	7	6	30
DES3 (30, 40, 50) - 100 [N,P]	0°	14	14	6	66
	45°	39	8	10	66
w/1 side shield	0°	29	8	6	66
w/2 side shields	0°	16	16	6	66
20 ft. from burner	0°	7	7	6	30
DES3 (30, 40, 50, 60) - 125 [N,P]	0°	20	20	6	76
	45°	58	8	10	76
w/1 side shield	0°	42	8	6	76
w/2 side shields	0°	20	20	6	76
20 ft. from burner	0°	7	7	6	30
DES3 (40, 50, 60) - 150 [N,P]	0°	24	24	6	81
	45°	58	8	10	81
w/1 side shield	0°	42	8	6	81
w/2 side shields	0°	23	23	6	81
20 ft. from burner	0°	11	11	6	44
DES3 (40, 50, 60, 70) - 175 [N,P]	0°	34	34	6	92
	45°	63	8	10	92
w/1 side shield	0°	50	8	6	92
w/2 side shields	0°	30	30	6	92
20 ft. from burner	0°	11	11	6	44
DES3 (50, 60, 70, 80) - 200 [N,P]	0°	41	41	6	94
	45°	63	8	10	94
w/1 side shield	0°	54	8	6	94
w/2 side shields	0°	30	30	6	94
20 ft. from burner	0°	11	11	6	44

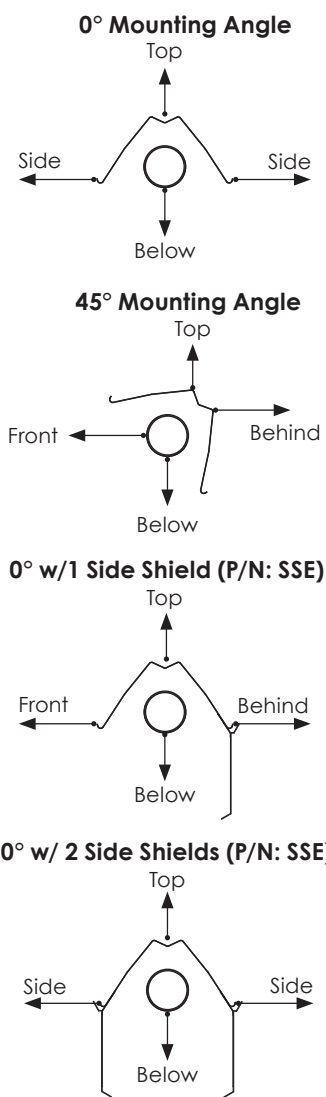

<sup>3</sup> Heaters mounted on an angle between 0° and 45° must maintain clearances posted for 0° or 45°, whichever is greater.



Read and understand the installation, operation, and maintenance manual prior to installing or servicing this unit.

In locations used for the storage of combustible materials, signs must be posted adjacent to the heater's thermostat specifying stacking heights.

# DES3 SERIES FIELD DATA

Burner Control Box with U-Bend - End View

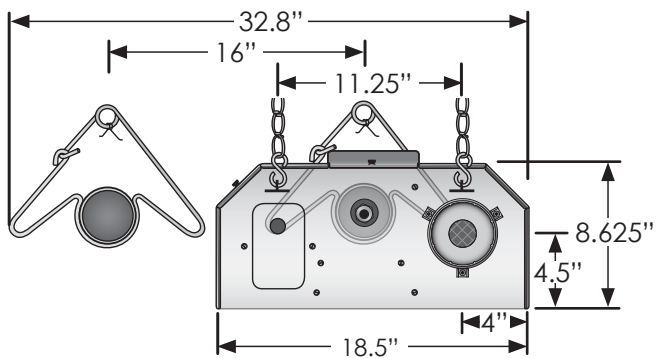

Side View

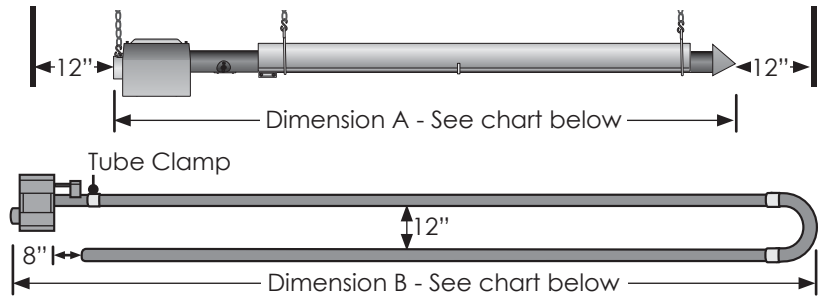
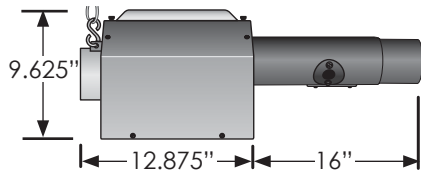

MODEL NUMBER	DIMENSION A STRAIGHT	DIMENSION B U-TUBE
DES3-20	21'-9"	13'-1"
DES3-30	31'-5"	17'-9" <sup>4</sup>
DES3-40	41'-1"	22'-9"
DES3-50	50'-9"	27'-5" <sup>4</sup>
DES3-60	60'-5"	32'-5"
DES3-70	70'-1"	37'-3" <sup>4</sup>
DES3-80	79'-9"	42'-1"

<sup>4</sup>with 5EA-SUB

## OPTIONAL ACCESSORIES

QTY.	PART #	DESCRIPTION	NOTES
	10EA	10' X 4" Tube & Reflector Extension	Optional 10 ft. extension package. Maximum of one per unit.
	4-DSK	4" Sidewall Vent Kit	Required for all single sidewall vents. No roof venting.
	6-DSK	6" Sidewall Vent Kit	Required for all common sidewall vents. No roof venting.
	BK	Angle Mounting Bracket 15-30-45 Deg.	Rotates reflector to preset mounting angles.
	E6	90 Degree, 4" Radiant Elbow	Used for making a L-shaped heater. Maximum of two per unit.
	PG	Protective Guard	Protects heat exchanger from contact or objects. Each 5 ft. in length.
	PLQ	Warning Plaque	Hung below heater, restates the clearance to combustible warning.
	REP	Reflector & Elbow Package	Reflector and accessories used to configure heater in a 'L' shape.
	RTVP-4	4" Rooftop Vent Package	Used to single vent vertically through the roof.
	RTVP-6	6" Rooftop Vent Package	Used to common vent vertically through the roof.
	RUP	Reflector & 'U' Bend Package	Reflector and accessories used to configure heater in a 'U' shape.
	SMB	Single Mount Bracket	Provides units with 'U' bend uniform mounting points. One per 10 ft.
	SSE	Side Shield Extension	Reflector side guard used to lower side clearances. Each 5 ft. in length.
	TF1B	180 Degree, 4" Radiant 'U' Bend	Used for making a U-shaped heater. Maximum of one per unit.
	THCS	Tube Heater Chain Set	5 ft. chain set with two S-hooks used for hanging heater.
	HRE-60	5' x 4" Tube & Reflector Extension	Optional 5 ft. extension package. Maximum of two per unit.
	WIV-4	4" Combustion Air Intake - Sidewall Cap	Used to duct fresh (cold) air 0-30 ft. to a heater. Sidewall only.
	WVE-GALV	4" Unvented Exhaust Termination Cap	Required on all units when operating unvented.
	Y	4" x 6" x 4" Aluminized Common Vent	Used for joining two heaters on one vent. Same thermostat required.
	YSM	4" x 6" x 4" Galvanized Common Vent	Used for joining two heaters on one vent. Same thermostat required.
	GC-50	1/2" x 1/2" FTP ball valve with 1/8" NPT side inlet pressure tap. 2 PSI maximum pressure.	Used on gas piping upstream of flex connector.

### OPTIONAL UPGRADES

- SILSEAL** Protects internal burner box components against contaminants.
- 5EA-SUB** Substitute one 10 ft. radiant tube and reflector for two 5 ft. pieces. This is ideal for making U-shaped heaters from 30 ft. and 50 ft. models. Maximum of one per heater.
- ALUM-AO** Upgrade hot-rolled steel tubes to black coated 16 ga. aluminized steel tubes.
- 24VAO** Adds internal relay and terminal strip to allow the heater to utilize 24 V controls instead of the standard 120 V.
- IND-LT** Indicator lights for burner, exhaust and valve operation.

### STAINLESS STEEL UPGRADES

- SSRAO** 10 ft. Reflector Section.
- SSC-##** Tube Clamps (## = heater length).
- SSB-##** Mounting Brackets (## = heater length).
- SSE-SS** Side Shield Extension.

**NOTE:** Refer to the Tube Heater Packing List (F/N: LPKTH) for detailed specifications and limitations on any of the above options.

# DES3 WRITTEN SPECIFICATIONS

## PRODUCTS

### 1. TUBULAR INFRARED HEATERS

- A. Basis-of-design product: Subject to compliance with requirements, provide Detroit Radiant Products Company; **Re-Verber-Ray® DES3 Series**.
- B. Fuel type: Burner shall be designed for [natural] [propane] gas having characteristics same as those of gas available for project site.
- C. Combustion chamber: Shall be 4 inch O.D., 16 gauge, titanium-stabilized aluminized steel (150 to 200 MBH to allow for the operating temperature to exceed the 1030°F as set forth in the ANSI Z83.20 Standard) or aluminized steel (below 150 MBH), finished with a high emissivity rated, corrosion-resistant, black coating with an emissivity level documented at .92 or higher.
- D. Emitter tube: Shall be 4 inch O.D., 16 gauge, hot-rolled steel.
- E. Burner type: Unit shall be a positive pressure power burner with a combustion fan upstream of the burner and exhaust gases for component longevity, maximum combustion efficiency, and energy transfer. Negative pressure (pull through) type appliances shall not be permitted.
- F. Fan enclosure: Combustion fan shall be totally housed inside burner control box and not exposed. Appliances with exposed combustion/exhauster fans shall not be permitted.
- G. Burner: Stainless steel venturi burner. The flame anchoring screen shall have a minimum temperature rating equivalent to 304 grade stainless steel. Non stainless steel burners shall not be permitted.
- H. Tube connections: The heater's combustion chamber and radiant emitter tube shall incorporate a 4 inch slip-fit, interlocking connection in which the upstream tube slides into the next tube and is held by a bolted clamp. A butted tube connection system shall not be permitted.
- I. Ignition system: Direct spark igniter with flame rod sensing capabilities.
- J. Reflectors: Shall be .025 polished aluminum with a multi-faceted design which includes reflector end caps. Reflector shall have a polished bright finish with clear visual reflection ability. (A sample will be required at time of submittal). Reflector shall have a minimum of 7 sheet metal bends in its fabrication to optimize downward radiation. Reflectors shall be rotatable from 0° to 45° when required. The heater's reflector hanging system shall be designed to permit expansion while minimizing noise and/or rattles.
- K. Control box: Heater's exterior control chassis shall be constructed of corrosion resistant enameled steel.
  1. Air intake: An air intake collar shall be supplied as part of the burner control assembly to accept a 4 inch O.D. supply duct.
  2. The heater's control compartment shall be easily serviceable by removing one (1) panel.
- L. Heaters shall be equipped with a sight glass allowing a visual inspection of igniter and burner operation from the floor. Sight glass visible only at appliance level shall not be permitted.
- M. The heaters shall utilize a downstream turbulator baffle for maximum heat transfer.
- N. Heater shall be supplied with a stainless steel flexible gas connector.
- O. Burner Safety Controls:
  1. Heater controls shall include a safety differential pressure switch to monitor combustion air flow, as to provide complete burner shutdown due to insufficient combustion air or flue blockage.
  2. The heater's control system shall be designed to shut off the gas flow to the main burner in the event either a gas supply or power supply interruption occurs.
  3. The heater's blower motor shall be thermally protected and the motor's impeller shall be balanced.
  4. The heater's air flow control system shall provide a 7 second pre-purge prior to initiating burner operation.
  5. No condensation shall form as a result of combustion in the combustion chamber or radiant tubes while at operating temperatures.
- P. Venting: Shall be per manufacturer approval and specifications.
- Q. Thermostat: Devices and wiring are specified in Division 23 Section "Instrumentation and Control for HVAC."
  1. Thermostat: Single stage, digital programmable wall-mounting type with 45° to 90°F (7° to 32°C) operating range.