

DSC Series Installation Manual



⚠ WARNING



Improper installation, adjustment, alteration, service, or maintenance can cause property damage, injury, or death. Read and understand the installation, operating, and maintenance instructions thoroughly before installing or servicing this equipment.

This heater must be installed and serviced by trained gas installation and service personnel only. Inspect the heater annually. Failure to comply could result in personal injury, asphyxiation, death, fire, and/or property damage.



Storage of gasoline and other flammable vapors and liquids in the vicinity of this or any other appliance may result in fire or explosion. Do not store or use gasoline or other flammable vapors and liquids in the vicinity of this or any other appliance. A propane cylinder not connected for use shall not be stored in the vicinity of this or any other appliance. Maintain all clearances to combustibles at all times.



For outdoor use only. This heater is not approved for use in any indoor residential application. This includes, but is not limited to, attached garages, solariums, living quarters, etcetera. Installation in residential indoor spaces may result in property damage, asphyxiation, serious injury, or death.

⚠ DANGER

If you smell gas:

1. Shut off gas to the appliance.
2. Extinguish any flame.
3. If odor continues, keep away from the appliance and immediately call your gas supplier or fire department.

INSTALLER: Present this manual to the end user.

Keep these instructions in a clean and dry place for future reference.

Model#: _____ Serial #: _____
(located on rating label)

LIODSCS-Rev. 32513
Print: LIODSCS-1M-06/26 (CDS)
Replaces: LIODSCS-1M-04/24 (CDS)

Contents

1.0 Safety	3
Safety Symbols	3
Applications	3
Clearances to Combustibles	4
Standards, Certifications, and Government Regulations	6
Safety Labels and Their Locations	8
2.0 Installation	9
Design	9
Heater Mounting	10
Recommended Mounting Heights	11
Gas Supply	13
Gas Connection	14
Leak Testing	16
Electrical Requirements	17
Wiring Diagrams	18
Ventilation	20
3.0 Operation	21
Sequence of Operation	21
4.0 Maintenance	22
Periodic Maintenance	22
Service Access Panel Removal	23
Troubleshooting Guide	24
Maintenance Log	25
5.0 Parts	26
6.0 Limited Warranty	28

WARNING

California Proposition 65

This product can expose you to chemicals including lead and carbon monoxide, which are known to the State of California to cause birth defects or other reproductive harm.

For more information, go to www.P65Warnings.ca.gov.

1.0 Safety

⚠ WARNING



Improper installation, adjustment, alteration, service, or maintenance can cause property damage, serious injury, or death. Read and understand the installation, operating, and maintenance instructions thoroughly before installing or servicing this equipment. Only trained, qualified gas installation and service personnel may install or service this equipment.

Safety Symbols

Safety is the most important consideration during installation, operation, and maintenance of the infrared heater. You will see the following symbols and signal words when there is a hazard related to safety or property damage.

⚠ DANGER

Danger indicates a hazardous situation which, if not avoided, will result in death or serious injury.

⚠ WARNING

Warning indicates a potentially hazardous situation which, if not avoided, could result in death or injury.

⚠ CAUTION

Caution indicates a potentially hazardous situation which, if not avoided, could result in minor or moderate injury.

NOTICE

Notice indicates a potentially hazardous situation which, if not avoided, could result in property damage.

Applications

This is not an explosion proof heater. Consult your local fire marshal, insurance carrier, and other authorities for approval of the proposed installation.

Commercial / Industrial

This patio heater is specifically designed to provide heated comfort in an outdoor environment. When properly integrated into a patio design, the heaters generally increase comfort levels.

Outdoor Residential

This heater may only be used in outdoor residential applications and is NOT approved for use in any indoor residential application. This includes, but is not limited to, attached garages, living quarters, solariums, etcetera. Consult the local fire marshal and/or insurance provider if unsure of your application.

⚠ WARNING



Not For Indoor Residential Use. Installation of an infrared heater system in residential indoor spaces may result in property damage, serious injury, or death. In residential applications this heater may only be used outdoors.

Clearances to Combustibles

⚠ WARNING



Placement of explosive objects, flammable objects, liquids, and/or vapors close to the heater may result in explosion, fire, property damage, serious injury, or death. Do not store, or use, explosive objects, liquids, and/or vapors in the vicinity of the heater.

Failure to comply with the published clearances to combustibles could result in personal injury, death, and/or property damage.

A critical safety factor to consider before installation is the clearances to combustibles. **Clearance to combustibles** is defined as *the minimum distance you must have between the infrared surface, or reflector, and the combustible item*. Considerations must also be made for moving objects around the infrared heater. The following is a partial list of items to maintain clearances from:

Combustible items:

- Wood
- Paper
- Fabric
- Chemicals
- Wall or roof insulation
- Plastics

Moving Objects:

- Overhead doors
- Vehicle lifts
- Cranes
- Hoists
- Car wash equipment

Hazards:

For maximum safety the building must be evaluated for hazards before installing the heater system. Examples include, but are not limited to:

- Gas and electrical lines
- Combustible and explosive materials
- Chemical storage areas
- Areas of high chemical fume concentrations
- Provisions for accessibility to the heater
- Adequate clearances around air openings
- Combustion and ventilating air supply
- Vehicle parking areas
- Vehicles with lifts or cranes
- Storage areas with stacked materials
- Lights
- Sprinkler heads
- Overhead doors and tracks
- Dirty, contaminated environment

⚠ CAUTION



In locations used for the storage of combustible materials, signs must be posted to specify the maximum permissible stacking height to maintain the required clearances from the heater to the combustibles. Signs must either be posted adjacent to the heater thermostats or, in the absence of such thermostats, in a conspicuous location.

Children and adults should be alerted to the hazards for high surface temperatures and should stay away to avoid burns or clothing ignition.

Young children should be carefully supervised when they are in the same space as the heater.

Clothing or other flammable materials should not be hung from the heater, or placed on or near the heater.

Any guard or other protective device removed for servicing the heater must be replaced prior to operating the heater.

Installation and repair should be done by a qualified service person. The heater should be inspected before use and at least annually by a qualified service person. More frequent cleaning may be required as necessary. It is imperative that the control compartment, air passageways, and burner of the heater are kept clean.

When installing the infrared heater system, the minimum clearances to combustibles must be maintained. These distances are shown in Chart 1.1 and on the heater. If you are unsure of the potential hazards, consult your local fire marshal, fire insurance carrier, or other qualified authorities on the installation of gas fired infrared heaters for approval of the proposed installation.

Chart 1.1 • Clearances to Combustibles in Inches (see Figure 1.1)

Model No.	BTU/h	Voltage	Mounting Angle*	Sides	Back	Top	Below	Ends	Front
DSC-31	31,000	24 VAC	0°	18	N/A	13	48	12	N/A
			30°	N/A	18	18	40	12	36
DSC-34	34,000	24 VAC	0°	18	N/A	13	48	12	N/A
			30°	N/A	18	18	40	12	36

* Heaters mounted on an angle between 0° and 30° must maintain clearances posted for 0° or 30°, whichever is greater.

Important! If the heater is mounted beneath a non-combustible surface an 8 in. minimum top clearance must be maintained from the top of the heater to prevent overheating the controls.

Clearances to combustibles distances represent a surface temperature of 90°F (50°C) above ambient temperature. Ensure that building materials with a low heat tolerance (i.e, awnings, fabrics, plastics, sprinklers, insulation) are protected against degradation. This may require the heater to be mounted at a distance in excess of the published clearances to combustibles. Contact the factory or the building material manufacturer for additional information.

Figure 1.1 • Clearances to Combustibles

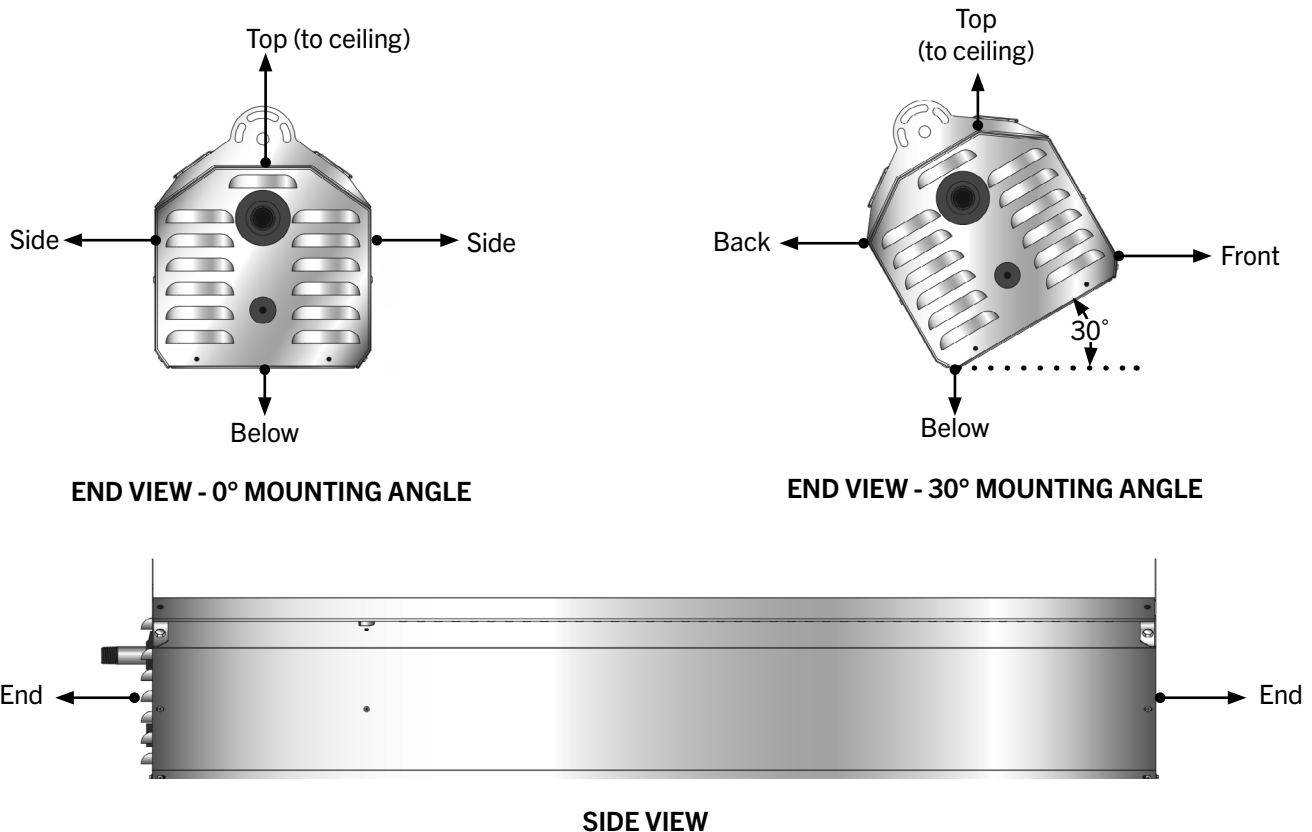

Standards, Certifications, and Governmental Regulations

The installation of this heater must comply with all applicable local, state, and national specifications, regulations, and building codes (contact the local building inspector and/or fire marshal for guidance) before installing the heater system.

In the absence of local codes, the installation must conform to the latest edition of the National Fuel Code ANSI Z223.1 (NFPA 54).

Refer to the following standards and codes for application specific guidelines:

Public Garages:

The installation of this heater in public garages must conform with the Standard for Parking Structures, ANSI/NFPA 88A (latest edition), and must be at least 8 ft. above the floor.

Aircraft Hangars:

The installation of this heater in aircraft hangars must conform with the Standard for Aircraft Hangars, ANSI/NFPA 409 (latest edition). The heater must be installed at least 10 ft. above the upper wing surfaces and engine enclosures of the highest aircraft which might be stored in the hangar. In areas adjoining the aircraft storage area, the heaters must be installed at least 8 ft. above the floor. The heaters must be located in areas where they will not be subject to damage by aircraft, cranes, moveable scaffolding or other objects.

High Altitude:

The installation of this heater is approved, without modifications, for elevations up to 2,000 ft. above MSL (sea level). Contact Detroit Radiant Products Company for installations above these elevations. Installation of this appliance at altitudes above 2000 ft. (610 m) shall be in accordance with local codes or, in the absence of local codes, ANSI Z223.1/NFPA 54 or CSA B149.1.

Gas Connection:

WARNING

An approved connector, suitable for the environment of equipment usage, is required. Visible or excessive swaying, flexing, and vibration of the gas connections must be avoided to prevent failure. Neither the gas pipe nor the connector shall be placed in the flue discharge area or in direct contact with infrared rays. In no case shall the gas supply support or bear weight of the heater.

To ensure your safety, and to comply with the terms of the warranty, all units must be installed in accordance with these instructions. Under no circumstance should the gas supply line provide support to the heater.

The gas supply to the infrared patio heater must be connected and tested in accordance with national, state, provincial, and local codes along with the guidelines in the manual. In the United States, refer to the latest edition of the ANSI Z223.1 (NFPA 54) Standard and in Canada, refer to the latest edition of the CAN/CGA B149.1 Standard.

Supply gas piping to the unit should conform to the local and national requirements for type and volume of gas handled and pressure drop allowed in the line. Avoid pipe sizes smaller than 1/2".

Electrical:

The heater, when installed, must be electrically grounded in accordance with the National Electrical Code ANSI/NFPA 70 (latest edition). Under no circumstances is the electrical supply line to provide any assistance in the suspension of the heater.

Ventilation:

This heater must be installed in accordance with the requirements set forth in this manual and with the NFPA 54/ANSI Z223.1 National Fuel Gas Code (latest edition). See ventilation requirements on page 19.

Re-Verber-Ray® units comply or are certified by one or more of the following organizations or standards:

- CSA International Requirement (CSA 2.37).
- American National Standards Institute (ANSI Z83.26).
- Intertek (ETL)
- Occupational Safety and Health Act (OSHA).
- NFPA 54/ANSI Z223.1 - National Fuel Gas Code.
- NFPA 70/ANSI - National Electrical Code.
- IRSC - Infrared Heater Safety.

Sprinkler Heads:

Fire sprinkler heads must be located at an appropriate distance from the heater to avoid accidental discharge of the fire suppression system. This distance may exceed the published clearances to combustibles (see Chart 1.1 on page 5). Certain applications will require the use of a higher classification of sprinkler heads or relocation of the heaters. Chart 1.2 is derived from NFPA 13 Table 3-2.5.1. Some manufacturers may supply sprinklers with temperature ratings that vary from the chart below. Consult the manufacturer of the sprinkler heads and NFPA 13 for more information.

Chart 1.2 • Sprinkler System Temperature Ratings

Classification	Max. Ceiling Temperature	Sprinkler Activation Temperature	Glass Bulb Color	Fusible Link Color
Ordinary	100°F	135°F - 170°F	Orange (135°F) Red (155°F)	Black or No Color
Intermediate	150°F	175°F - 225°F	Yellow (175°F) Green (200°F)	White
High	225°F	250°F - 300°F	Blue	Blue
Extra High	300°F	325°F - 375°F	Purple	Red
Very Extra High	375°F	400°F - 475°F	Black	Green
Ultra High	475°F	500°F - 575°F	Black	Orange
Ultra High	625°F	650°F	Black	Orange

Safety Labels and Their Locations

It is important to provide warnings to alert individuals to potential hazards and safety actions. Safety warning labels must be maintained on the infrared heater. Illustrations of the safety labels and their locations are pictured below. In locations used for the storage of combustible materials, signs must be posted to specify the maximum permissible stacking height to maintain the required clearances from the heater to combustibles. Signs must either be posted adjacent to the heater device or, in the absence of such control(s), in a prominent location.

Figure 1.2 • Heater Safety Label Locations

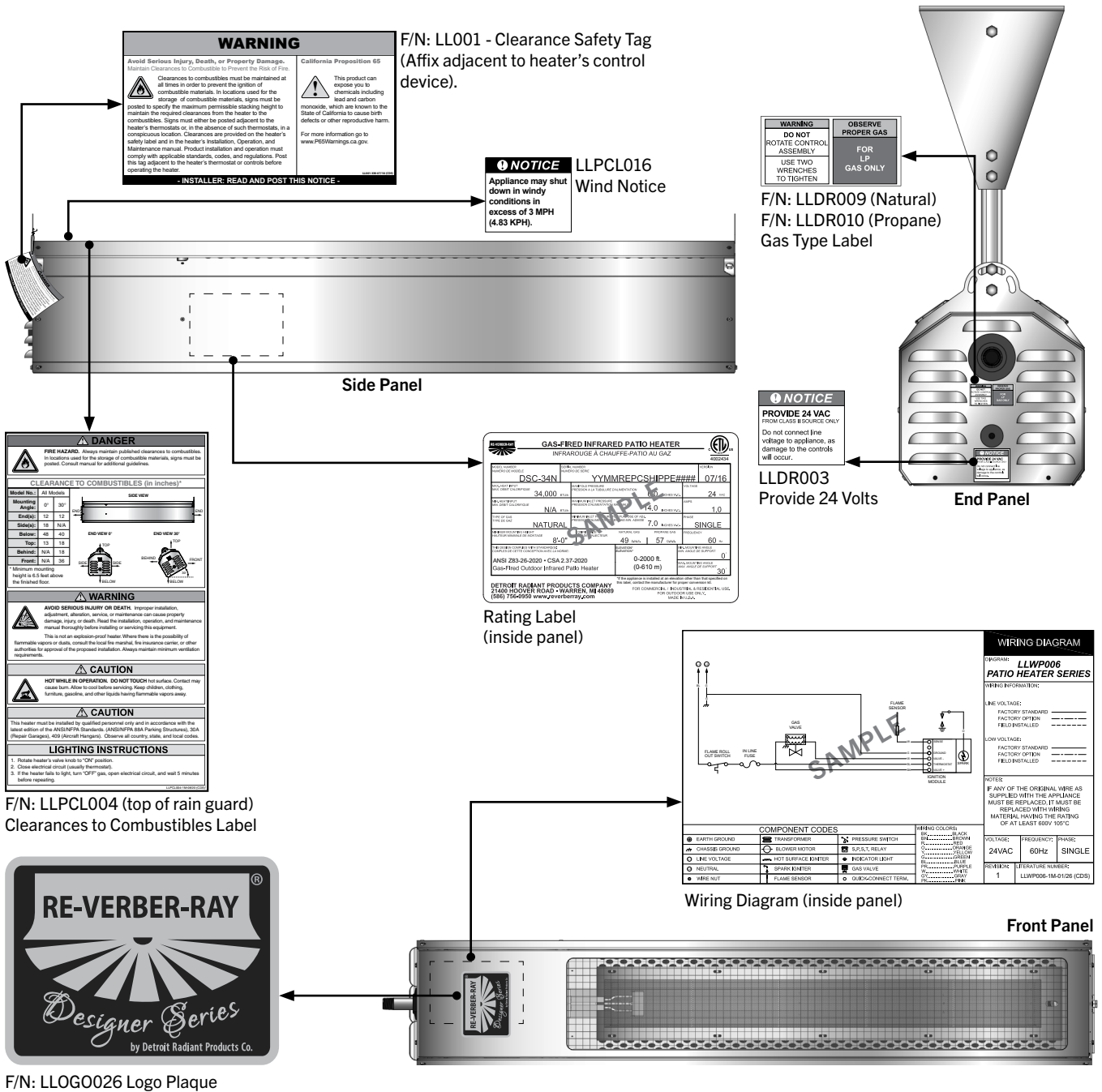

2.0 Installation

Design

Re-Verber-Ray® Patio Heaters are designed specifically for comfort heating in an outdoor environment. Examples of suitable applications include patios, porches, outdoor shopping areas, and outdoor pathways. When used properly, the heater will increase the comfort levels of its application. However, the effectiveness of the heating will depend on many variables such as air temperature, wind velocity, wind barriers, mounting heights, and distance between heaters. To ensure a safe, properly designed heating system, all of these variables should be considered prior to developing a layout for the infrared heaters.

NOTE: It is important to understand that the effectiveness of the heater may be diminished in environments with wind velocities above 3 MPH. Wind barriers can be extremely beneficial in maintaining the effectiveness of the heater and reducing the operational costs. However, if wind barriers are used, they must be designed in such a way that allows for the necessary fresh air and ventilation for the proper heater operation. In addition, all clearances to combustibles must be maintained at all times (See Chart 1.1 on page 5).

The heater must always be operated in a location that allows uniform air pressure around the heater. If one part of the heater is located outside of a wind protected zone, the heater may not properly function or damage to the heater may occur. Consideration should be taken on how the wind will affect the heaters after installation.

Patio heaters are installed in applications that have varying environmental conditions. The DSC series has passed basic wind and rain tests required to obtain certification. However, the successful completion of these tests does not guarantee that the heater will not be damaged or exhibit unsatisfactory performance due to certain environmental conditions, including rain and high wind. Ensure that heaters are inspected annually prior to the start of each heating season, and that necessary repairs are conducted before placing the heaters into operation (see page 22 for maintenance information).

The infrared patio heaters may be laid out in a number of configurations depending on the structure's constraints of the application, heating requirements, and therefore, the basic recommendations of installation. The minimum mounting height for all Re-Verber-Ray® Patio Heaters is 6.5 feet above the finished floor.

IMPORTANT: Fire sprinkler heads must be located at an appropriate distance from the heater to avoid accidental discharge of the fire suppression system. This distance may exceed the published clearances to combustibles (see Chart 1.1 on pg. 5). Certain applications will require the use of high temperature sprinkler heads or relocation of the heaters. Refer to Chart 1.2 on pg. 7 and NFPA 13.

NOTICE

Radiant heat is capable of damaging or destroying certain materials or items. Do not store materials or items underneath the heater. Always maintain clearances to combustibles.

⚠ CAUTION

Fire sprinkler systems containing propylene glycol, antifreeze, or other potentially flammable substances shall not be used in conjunction with this heater without careful consideration for and avoidance of inadvertent discharge hazards. For further information consult NFPA 13. Always observe applicable state and local codes.

Heater Mounting

⚠ WARNING



Improper suspension of the infrared heater may result in collapse and persons being crushed. Always suspend from a permanent part of the building structure that can support the total force and weight of the heater.



Failure to maintain minimum clearances to combustibles may result in fire and/or explosion, property damage, serious injury, or death. Always maintain minimum clearances and post signs or provided tags (F/N: LL001) where needed. Signs should state the hazards for the particular application and be legible for the building occupants. Consult the factory or a factory representative for additional information on signage compliance.

The heater shall be mounted in a fixed position attached from a structure that can evenly support the total force and weight of the heater. The mounting means shall be independent of the gas and electrical supply line. All hangers and bracket material shall be of noncombustible construction. Examples of suitable material include, but are not limited to, steel channel, steel tubing, threaded rod, or field fabricated hangers that are adequate to bear the load. In some cases, the heater may need to be isolated from vibration with the use of vibration isolating devices.

The heater must be level from side to side and can be set at an angle between 0° and 30° from horizontal.

Figure 2.1 • Heater Dimensions

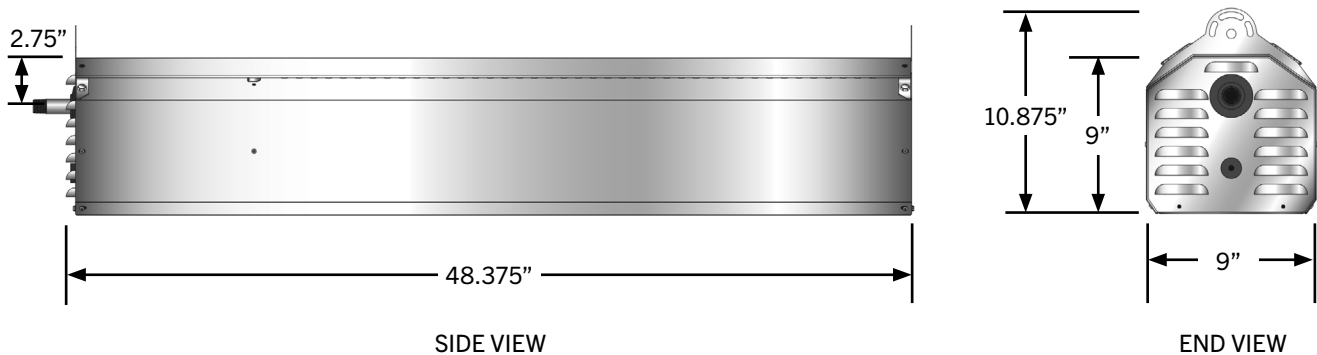

Optional Mounting Kit

Optional adjustable mounting kits and brackets are available for the patio heater. Refer to the insert that is included with the mounting brackets for complete installation instructions.

Recommended Mounting Heights

⚠ WARNING

Heater must be installed at least 6.5 feet above the finished floor.

Chart 2.1 • Recommended Mounting Heights

BTU/h	Recommended Mounting Height	Approximate Coverage Area	Approx. Coverage (sq. ft.)
31,000	8'-0" to 12'-0"	8' x 8'	64 sq. ft.
34,000	8'-6" to 13'-0"	9' x 9'	81 sq. ft.

NOTE: This chart is provided as a guideline. Actual conditions dictate variances from this data.

Figure 2.2 • Heater Orientation

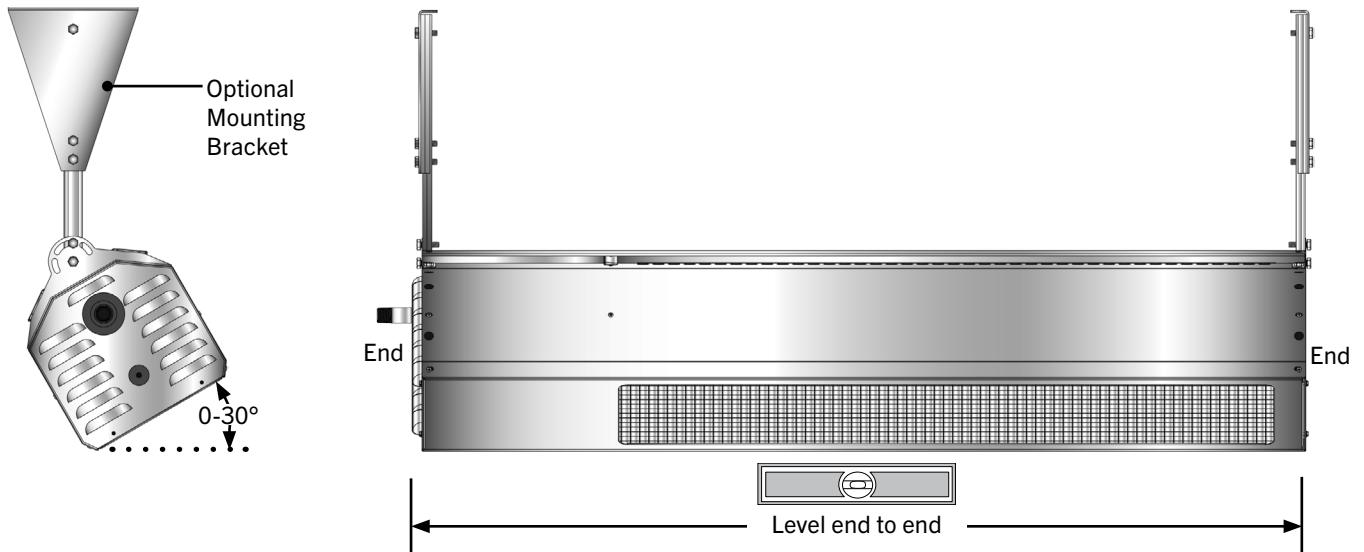
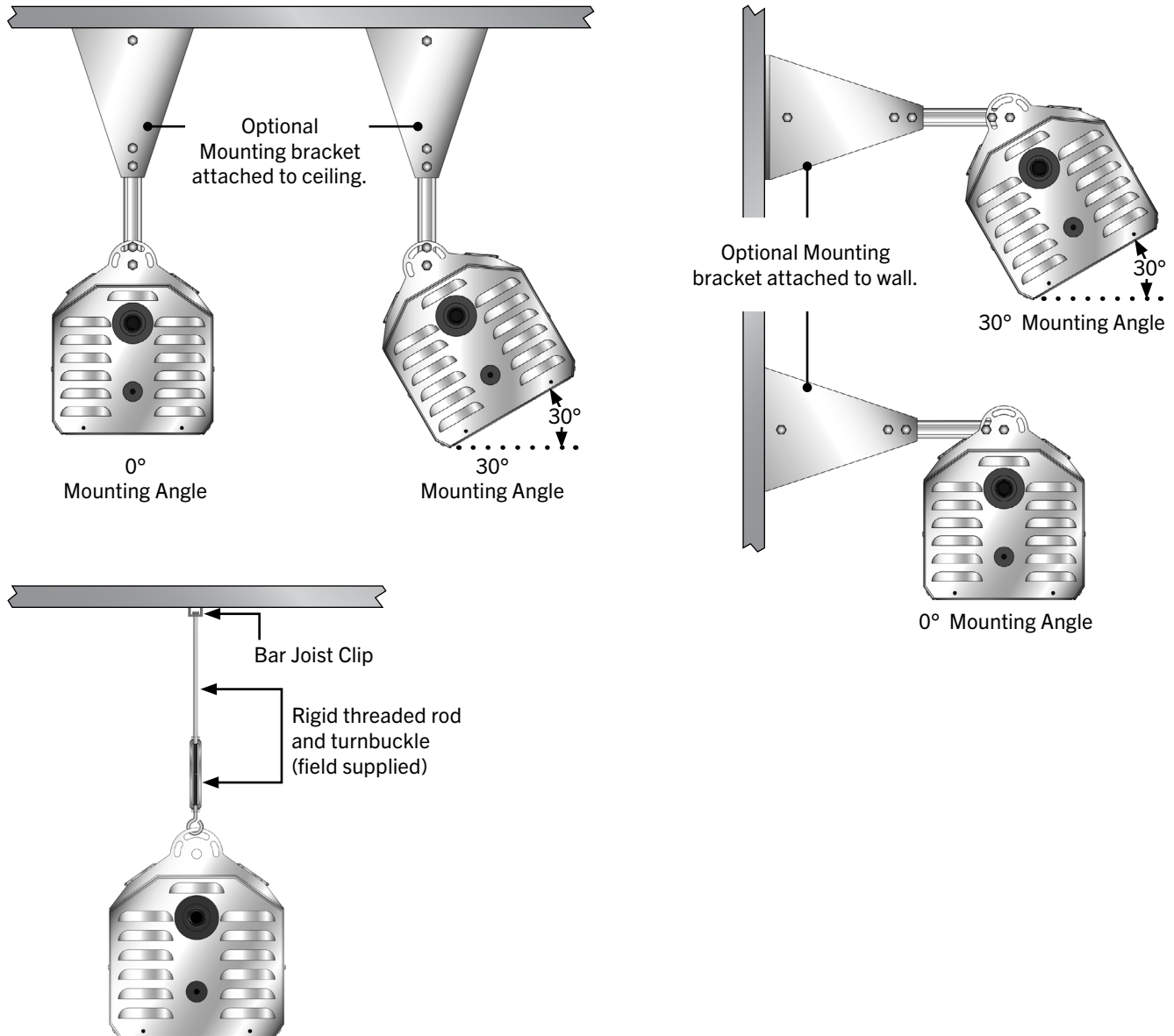

Figure 2.3 shows different types of mounting configurations. Depending on the type of mounting you use, be sure to:

- ❶ Prepare mounting surface. If necessary, weld blocks to mounting structure, drill holes, etc.
- ❷ Fasten beam clamp, screw hook, or other type of suspension anchor to hanging point.
- ❸ Attach threaded rod and turnbuckle to anchor. Check that it is securely attached.
- ❹ Attach heater to turnbuckle. Adjust turnbuckle until the heater is level and equal weight distribution is achieved. Threaded rod must be straight up and down, do not install threaded rod at an angle.

Figure 2.3 • Heater Mounting



Gas Supply

The gas supply to the infrared patio heater must be connected and tested in accordance with national, state, provincial, and local codes along with the guidelines in this manual. In the United States, refer to the latest edition of the ANSI Z223.1 (NFPA 54) standard and in Canada, refer to the latest edition of the CAN/ CGA B149.1 Standard.

⚠ WARNING



Improperly connected gas lines may result in fire, explosion, poisonous fumes, toxic gases, asphyxiation, and/or death. Connect gas lines in accordance to national, state, provincial, and local codes.

Supply gas piping to the unit should conform to the local and national requirements for type and volume of gas handled and pressure drop allowed in the line. Avoid pipe sizes smaller than 1/2".

NOTICE

The total input to the appliance must fall within +/- 5% of the rated input as indicated on the rating plate. Otherwise the burner may prematurely fail.

IMPORTANT! Before connecting the gas supply to the heater:

- Verify that the heater's gas type (as listed on the rating plate) matches that of your application and the installation complies with national and local codes and requirements of the local gas company.
- Unless otherwise noted on the rating plate, the infrared heater is designed and orificed to operate on standard BTU gas. Contact the factory if utilizing non-standard BTU gas.
- Check that the gas piping and service has the capacity to handle the total gas consumption of all the heaters being installed, as well as any other gas appliances being connected to the supply line.
- Check that the main gas supply line is of proper diameter to supply the required fuel pressures.
- If utilizing used pipe, verify that its condition is clean and comparable to a new pipe. Test all gas supply lines in accordance with local codes.

The gas outlet must be in the same space as the appliance installation, and must be accessible. It may not be concealed within or run through any wall, floor, or partition. When installing the heater in a corrosive environment or near corrosive substances, use a gas connector suitable for the environment. Do not use the gas piping to electrically ground the heater.

This heater is equipped to connect to 1/2" NPT gas pipe. All piping must be installed in accordance with the requirements outlined in the National Fuel Gas Code ANSI/Z223.1 (latest edition) or CSA B149.1 and B149.2. Support all gas piping with pipe hangers, metal strapping, or other suitable material. Do not rely on the heater to support the gas pipe.

When connecting gas piping to the unit, the use of a thread joint compound is required. The thread compound (pipe dope) shall be resistant to the action of propane gas or any other chemical constituents of the gas to be conducted through the piping. Use of Teflon® tape is not permitted.

Install a ground joint union with a brass seat and a manual shut-off valve adjacent to the unit for emergency shut-off and easy servicing of the controls. A 1/8" NPT plugged tap that is accessible for a test gauge connection is also recommended as illustrated in Figures 2.4 and 2.5.

A sediment trap must be installed in the supply line in the lowest spot prior to connecting to the heater. The trap length shall be at least three inches long. Ideally, the trap will be installed as close as possible to the shut-off.

Chart 2.2 • Gas Consumption and Manifold Pressure (Inches W.C.)

Model No.	Input	Manifold Pressure	Minimum Inlet Pressure	Maximum Inlet Pressure	Gas Consumption (CFH)	Gallons per Hour	Orifice Size
DSC-31N	31,000	6.0" W.C.	7.0" W.C.	14.0" W.C.	29.5	0.43	2.35 mm
DSC-31P	31,000	10.0" W.C.	11.0" W.C.	14.0" W.C.	12.4	0.34	1.65 mm
DSC-34N	34,000	6.0" W.C.	7.0" W.C.	14.0" W.C.	32.4	0.47	41 DMS

Pressure Equivalents: 1 inch W.C. equals .058 oz./sq. in. equals 2.49 Mbar.

⚠ WARNING



Improperly connected gas lines may result in serious injury or death, explosion, poisonous fumes, toxic gases, and asphyxiation. Connect gas lines in accordance with national, state, provincial, and local codes. Failure to disconnect the electricity before disconnecting the gas supply may result in explosion, fire, property damage, injury, or death.

⚠ WARNING



Conditions such as wind drafts or other variables can cause movement of the heater and may require it to be rigidly mounted. Avoid excessive movement and/or vibration of the gas connection by rigidly mounting the heater.

To connect the gas:

- ❶ Install a sediment trap / drip leg in the supply line at the lowest spot prior to the gas ball valve. The trap length shall be at least three inches long. Ideally, the trap would be installed as close as possible to the shut off. **NOTE:** For high pressure gas above 14" W.C., a high pressure regulator and ball valve must be utilized and located upstream of the flex connector.
- ❷ Install manual shut off ball valve with optional 1/8" NPT Test connection towards the supply line. The manual shut off ball valve must be located within 6 feet of the appliance's service access door.
- ❸ Install the 5/8" flare to 1/2" NPT adapter piece downstream of the gas valve as shown in Figure 2.4. This piece is typically included with the flexible gas connector, loosely installed on one of the flare nuts. **NOTE:** Keep flare surfaces clean and free of sealing compounds. Only the pipe threads require sealing compounds.
- ❹ Form the 1/2" x 24" stainless steel flexible gas connector into a smooth C-shape, allowing approximately 12 inches between the flexible connector's end nuts (see Figure 2.4). The connector must reach from the gas supply to the appliance without stretching, kinking, or twisting.
- ❺ Attach the flexible connector to the 5/8" flare adapter on the gas line and the other end to the 5/8" flare on the heaters inlet pipe. **DO NOT** connect the connector flare nuts directly to pipe threads. Use only the adapters provided. **DO NOT** kink, twist, or over-torque the connector when installing.

Figure 2.4 • Gas Connection (Flexible Gas Connection shown)

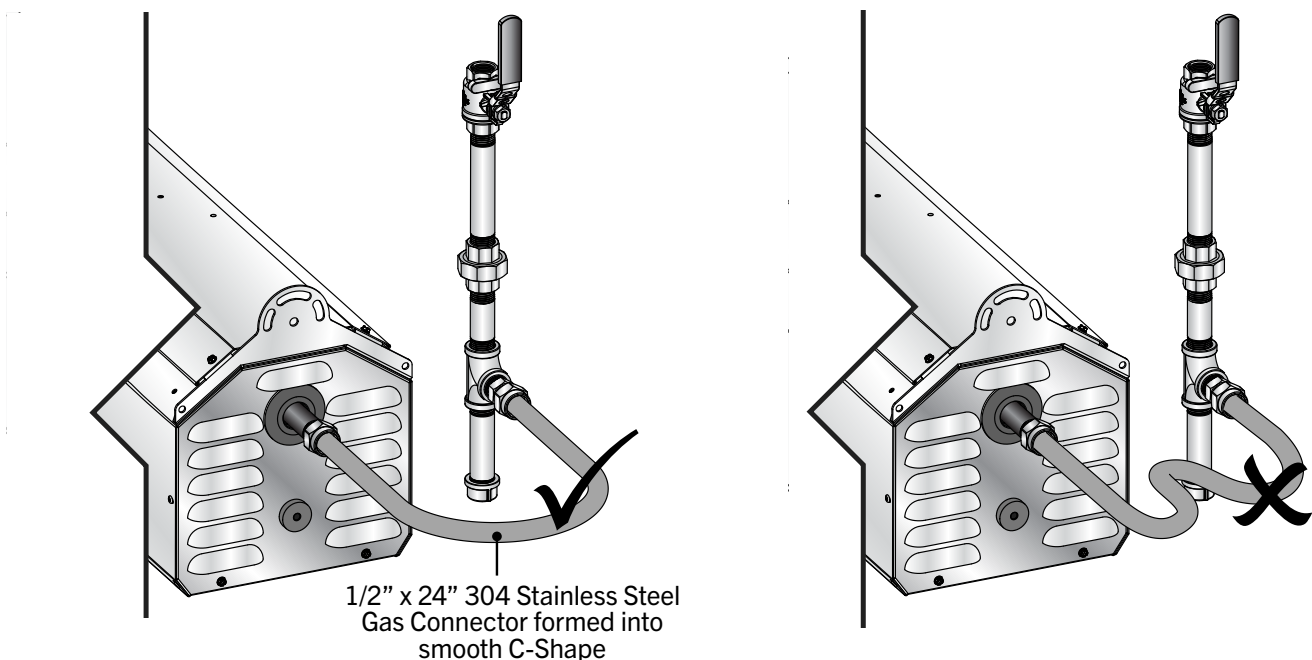

To disconnect the gas:

- ❶ Disconnect the power to the heater.
- ❷ Turn off the gas supply to the heater and "bleed" the gas line.
- ❸ Using two wrenches, slowly loosen the fittings. Excessive torque on the manifold may misalign the orifice.
- ❹ Inspect the gas pipe. Replace if necessary.
- ❺ Always cap off and leak check any open gas lines that are not in use.

Leak Testing

Use a soap solution or equivalent for leak testing. Leak testing solution must be non-corrosive, and be rinsed off immediately after the leak test. Never test for leaks with an open flame. Failure to comply could result in personal injury, property damage, or death.

Always leak test the final gas assembly for gas leaks according to the procedures outlined in NFPA 54 and all local codes/or standards.

⚠ WARNING



Failure to install, operate, or service this appliance in the approved manner may result in property damage, injury, or death. This heater must be installed and serviced by trained gas installations and service personnel only.

The installation of this heater must conform with local building codes or, in the absence of such codes, the National Fuel Code (NFPA 54).

⚠ WARNING



Testing for gas leaks with an open flame or other sources of ignition may lead to a fire or explosion and cause serious injury or death. Test in accordance with NFPA or local codes.

For leak testing on pressures below ½ PSI

Before leak testing, close the field installed manual shut off valve shown in Figure 2.4 (pg. 15) on the supply line to isolate the gas valve from the pressure. **NOTE:** All factory installed gas connections have passed an approved leak test.

For leak testing on pressures above ½ PSI

When leak testing with pressures above ½ PSI (14 inches W.C.) the unit's gas controls must be isolated from the supply pipe. Close the field installed manual shut off valve, disconnect the supply line to the unit, and temporarily cap the supply line for testing purposes.

⚠ WARNING



Gas pressures to the appliance controls must never exceed 14 inches W.C. (½ PSI). Supply pressures greater than 14 inches W.C. can damage the controls, resulting in personal injury, property damage, or death.

Electrical Requirements

⚠ WARNING



Incorrect or improper wiring may result in shock, injury, or death. Field wiring to the heater must be connected and grounded in accordance with national, state, provincial, and local codes, and to the guidelines in this manual. Refer to the most current revisions to the ANSI/NFPA 70 Standard.

All field wiring to the patio heater must be done in accordance with the national, state, provincial, and local codes, and to the guidelines in this manual. In the United States, refer to the most current revisions to the Electrical Code ANSI/NFPA 70 and in Canada, refer to the most current revisions of the Canadian Electrical Code CSA C22.1 Part 1. The unit must be electrically grounded according to these codes. This patio heater system is designed to operate on an external 24 VAC electrical system. Provide only 24 VAC with a NEC Class 2 transformer to the control wires inside the controls compartment. Use at least 18 AWG solid core thermostat type wire that has an adequate capacity and temperature rating for the total load. Never locate the transformer inside the controls compartment.

NOTICE

The power supply to the heater must be within +/-5% of the voltage rating as indicated on the rating plate of the appliance. If input power does not meet these specifications, contact your utility company.

Installing the control wire

Each heater includes a rubber grommet to allow for control wire to be brought into the unit with a water resistant seal. Feed the control wire through the grommet, piercing the rubber with the wire. Ensure enough wire length is available to make the proper connections. Tie the control wire into a loose knot, as shown in Figure 2.5. Ensure knot is loose enough to not cause any damage to the wire. This will allow for a strain relief for the connections to the heater.

Wiring: From the control wire, connect the 24 VAC to the blue wire (labeled “24 VAC”) inside the control compartment. Then connect the Common from the control wire to the green wire (labeled “Common”). For two stage units, there is a third wire. Connect this wire to the red wire labeled “High Fire.” See Fig 2.8, page 19.

Controls Operation

This patio heater was designed for use in an outdoor environment. Therefore, controlling the heater by use of a thermostat may not be the best means of temperature control. In an outdoor application, the air temperature may not increase and never satisfy the thermostat. The preferred control device when operating this heater in an outdoor area is a switching or timer device. In an application where there are several wind breaks or a partially enclosed area, a thermostat can be used.

Figure 2.5 • Control Wire Installation

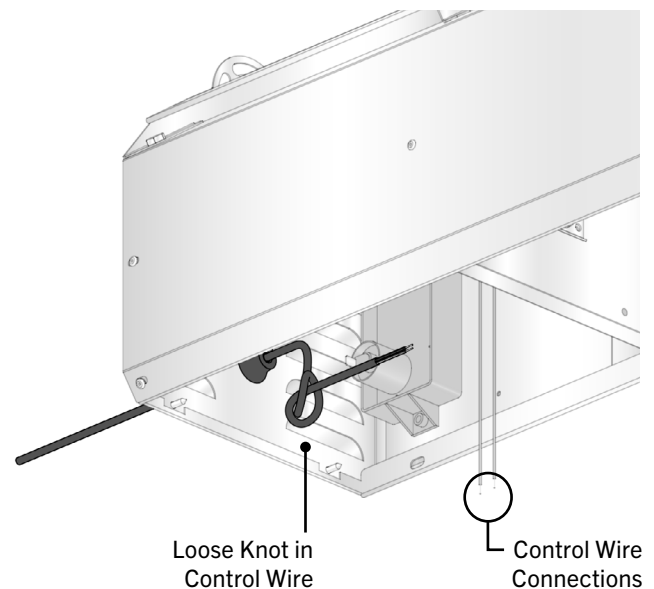
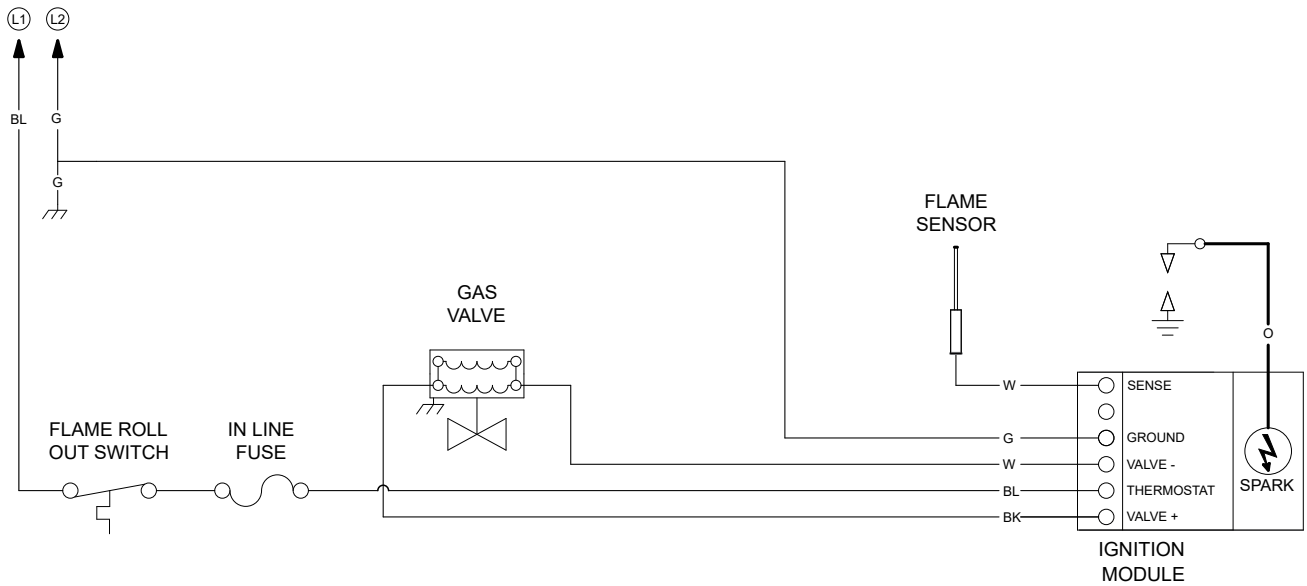

Figure 2.6 • Internal Wiring Diagram - Single Stage



WIRING INFORMATION:

LINE VOLTAGE:

FACTORY STANDARD 
 FACTORY OPTION 
 FIELD INSTALLED 

LOW VOLTAGE:

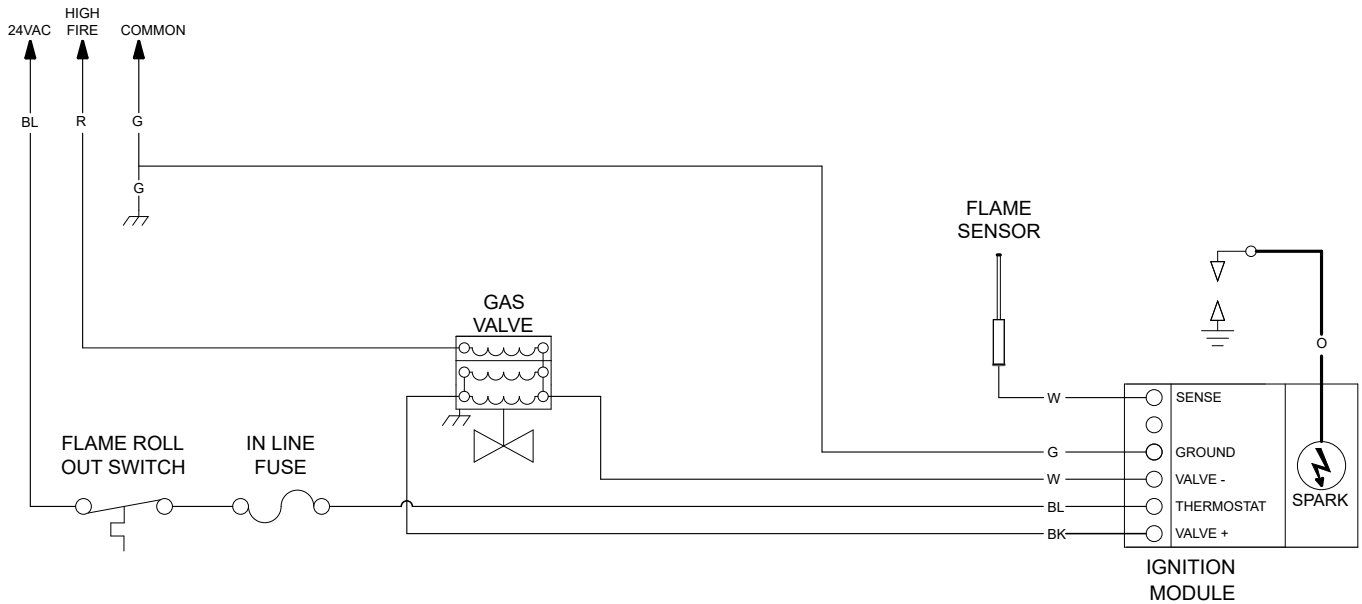

FACTORY STANDARD 
 FACTORY OPTION 
 FIELD INSTALLED 

Figure 2.7 • Internal Wiring Diagram - Two Stage



WIRING INFORMATION:

LINE VOLTAGE:

FACTORY STANDARD 
 FACTORY OPTION 
 FIELD INSTALLED 

LOW VOLTAGE:

FACTORY STANDARD 
 FACTORY OPTION 
 FIELD INSTALLED 

Figure 2.8 • Field Wiring Diagram

Single Stage Starting Amp Draw: 0.65 Amp
 Single Stage Running Amp Draw: 0.48 Amp

Two Stage Starting Amp Draw: 0.61 Amp
 Two Stage Running Amp Draw: 0.55 Amp

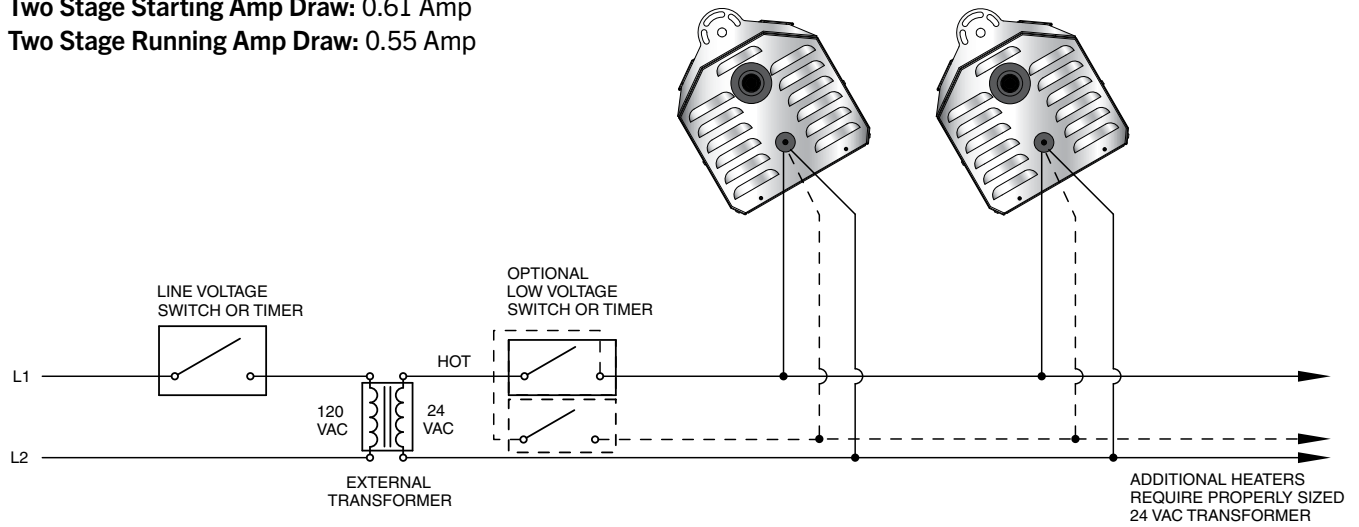

Field Wiring:

- ❶ 24 VAC/20 VA (.8 Amp) per heater is required (supplied by installer).
- ❷ Maintain electrical polarity when hooking up multiple heaters.
- ❸ Allow heaters to be switched by zones for heating flexibility.
- ❹ Do not attempt to install transformer inside of heater.

Ventilation

⚠ WARNING



Improper or insufficient ventilation may result in explosion, fire, health problems, carbon monoxide poisoning, or death. Vent enclosed spaces and buildings according to national, state, provincial, and local codes.

This infrared heater must be vented in accordance with national, state, provincial, and local codes, and to the guidelines in this manual. Refer to the latest edition of the ANSI Z223.1 (NFPA 54) Standard.

It is required that the upper levels of the space to be heated are properly ventilated to supply combustion air to the heaters and to sufficiently dilute the products of combustion. It is also important to keep the flue discharge area clear of gas piping and electrical wiring (see Figure 2.9).

Provisions must also be made to provide sufficient fresh air intake area and exhaust air outlet area. Natural or mechanical means shall be provided to supply and exhaust at least 4 CFM/1,000 BTU/h of total gas input of heaters installed. Exhaust openings for the removal of flue products must be above the level of the heater(s).

Where insufficient air movement exists, induced air displacement is required. A balanced system is essential to avoid negative building pressure which causes excessive infiltration, unfavorable drafts, and affects combustion efficiency.

Air displacement may be accomplished by either gravity or mechanical means. Mechanical exhausters are preferred and typically mounted at high points on the roof over where stagnant air accumulates inside. For a flat roof, considerations of prevailing winds, high and low pressure areas, and distribution of air movement must be taken into consideration when locating exhausters.

Best air distribution is accomplished by using a number of small exhausters versus one large exhauster. Provide a minimum of one square inch of inlet area per 1,000 BTU/h for combustion air supply. Inlet opening in the building should be well distributed, located high on the wall, and should direct incoming air upward to dilute products of combustion while preventing drafts at lower levels. Inlets are typically 1 to 3 square feet.

In certain applications, local codes may require that mechanical exhaust systems be interlocked with the heaters to enable both to function simultaneously or allow control of exhausters with a ceiling mounted humidistat.

Figure 2.9 • Hot Flue Discharge



Discharge released from side air channels. Keep area clear of gas piping and electrical wiring.

3.0 Operation

⚠ WARNING



Improper operation of the heater may result in explosion, fire, shock, and carbon monoxide poisoning. Follow all guidelines and warnings in this manual and national, state, provincial, and local codes. Always conduct safety checks before operating the heater. Do not operate the heater in unsafe conditions.

Important! Before operating the heater, conduct the following safety procedures:

- Check for any possible gas leaks.
- Alert all persons about the hazards of high surface temperatures and to keep a safe distance away in order to avoid burns and possible clothing ignition.
- Provide supervision when young children are in the area of the heater.
- Check to make sure clothing isn't hung from the heater and that flammable materials are not placed on or near the heater.
- Check that all guards or protective devices are in place and secure.
- Check control compartment, burners, and circulating air passages for debris. If necessary, clean the debris.

Sequence of Operation

Starting Circuit:

When voltage is applied to the controls connection, the ignition module sends power to the gas valve while simultaneously sending spark to the igniter. The ignition time is 15 seconds. Once the flame on the burner is established, the ignition module will continuously monitor the flame. The heater will continue to run as long as there is 24 VAC present in the call for heat. If the heater does not light on the first trial, the heater will attempt two more ignitions prior to going into a lockout mode.

Running Circuit:

After ignition, the flame rod monitors the flame. As long as a flame is present, the valve is held open. If the flame is lost, the control acts to close the valve within one second, and a new trial sequence identical to that at start-up is initiated. If proof of flame is not established within the 15 second trial for ignition, the unit will retry two additional times before entering lockout mode. If lockout occurs, the control can be reset by briefly interrupting the power source.

Two Stage Running Circuit:

The second stage on the gas valve is powered directly from the second stage of the control. In order for two stage to flow to a higher output, single stage must be energized as well. The control determines which stage to maintain for the desired temperature.

4.0 Maintenance

⚠ WARNING



Always wear clothing that protects the body and use protective glasses when servicing the heater.

Electrical shock or explosion may occur when conducting maintenance while the heater is connected to the power source and gas supply. Disconnect power and gas supply to heater before servicing.

Burner malfunction may result in explosion or fire. Never operate the heater if there are any signs of malfunction, excessive wear, or damage. Call a professional for assistance.

Before each use:

- Check the gas supply line for any possible leaks or damage.
- Check heater elements for debris. Visually check burner flames.
- Keep the heated area clear and free of combustible materials, gasoline, and flammable vapors and liquids. Ensure there is no obstruction of the flow of combustion and ventilation.

Periodic maintenance:

- Clean the heater with cleaning agents suitable for the unit's construction material (i.e., stainless steel cleaner).
- Inspect the gas supply piping system for signs of corrosion or failure. Replace if necessary.

Before conducting maintenance on the heater disconnect the power and gas supply. When pressure testing the gas supply piping system follow these guidelines:

- At a test pressure in excess of 1/2 psi (3.5 kPa), the heater and ball shutoff valve must be disconnected from the gas supply piping system during any pressure testing of the system.
- At a test pressure equal to or less than 1/2 psi (3.5 kPa), the heater must be isolated from the gas supply piping system by closing its individual manual shutoff valve during any pressure testing of the gas supply piping system.

Cleaning the main burner:

NOTICE

Cleaning the heater elements with high pressure air may cause damage to the elements and equipment failure. Do not blow out heating elements with high pressure air.

- 1 Use an air hose to blow any accumulated dust and/or dirt off the heater. Air hose pressure should not exceed 30 psi.
- 2 Pass the air hose over the entire exposed area of the ceramic. A distance of 2' to 4' from the unit is recommended.
- 3 Place the air hose outlet into the venturi tube and allow the air to flow for approximately one minute.

During long periods of non-usage, remove or cover heater with a polyethylene bag and shut off gas supply. If further service to the heater is desired, contact your representative or the factory.

Service Access Panel Removal and Installation

Allow the unit to cool completely before servicing. To remove the service access panel a ¼" nut driver will be needed. **Note: Use caution when handling the service access panel as the egg crate may contain sharp edges.** The use of protective gloves is highly recommended.

- 1 Remove the two ¼" screws on the control end of the unit first while holding the panel in place (see Figure 4.1).
- 2 The service access panel is supported at the opposite end by two pins. Carefully pull the control end of the panel down while pulling the panel towards the control end of the heater to disconnect from pins.
- 3 To reinstall, insert the non-control end of the service panel onto the pins. Carefully lift and slide the panel into place. While keeping the panel supported, insert the two ¼" screws on the control end.

Failure to support the service access panel during removal can result in damage to the piece and or uncontrolled dropping of the panel possibly causing injury.

⚠ WARNING



Detroit Radiant Products Company makes every possible effort to remove sharp edges, however, caution should be taken to avoid contact with potentially sharp edges on the heater housing. Sharp edges may cut, resulting in personal injury.

Figure 4.1 • Service Access Panel Removal

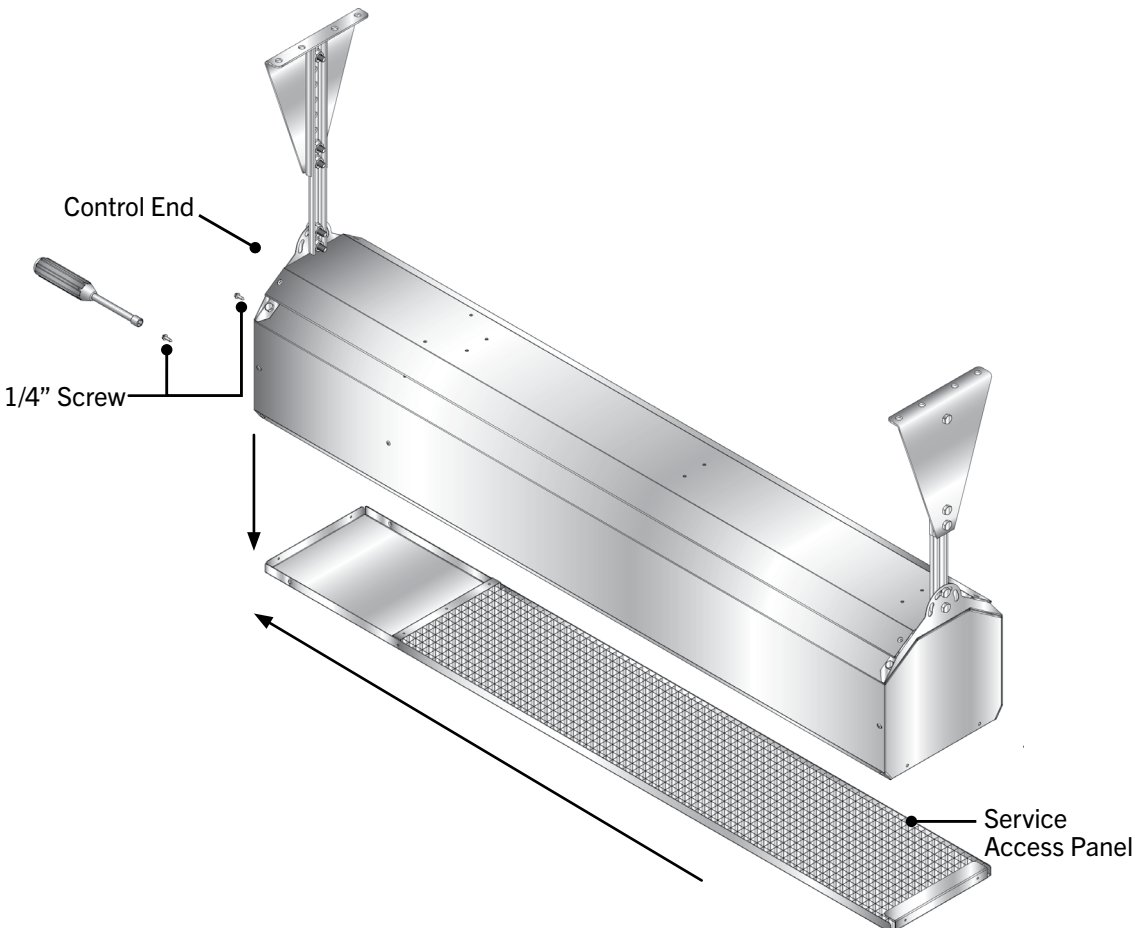

Chart 4.1 • Troubleshooting Guide

Symptom	Possible Cause	Corrective Action
Burning of gas-air mixture inside plenum (flashback). Rumbling noise present.	<ul style="list-style-type: none"> • Heater mounted at incorrect angle. • Excessive drafts. • Gas leaking at orifice. • Separation of ceramic grids. • Ceramic grids cracked. 	<ul style="list-style-type: none"> • Mount at a 0° - 30° angle from horizontal. • Relocate heater or shield from draft. • Check with leak detector solution. • Replace burner. • Replace burner.
Delayed ignition.	<ul style="list-style-type: none"> • Electrode out of specification. • Low gas pressure. • Partially blocked orifice. • Improper orifice size. • Incorrect gas. 	<ul style="list-style-type: none"> • Adjust or replace. • See Section 2.0, Gas Supply. • Clean or replace gas orifice. • Consult distributor. • See unit rating plate.
Low ceramic surface temperature or excessive rollout.	<ul style="list-style-type: none"> • Dirty or plugged burner ceramics. • Partially blocked orifice. • Low inlet gas pressure. • High or low manifold gas pressure. • Foreign matter in venturi tube. • Excessive dark spots on burner. • Gas supply piping too small. • Incorrect gas. 	<ul style="list-style-type: none"> • See periodic maintenance instructions. • Remove and clean. • See Section 2.0, Gas Supply. • Adjust main valve regulator as specified. • See periodic maintenance instructions. • See periodic maintenance instructions. • Increase inlet pressure or replace piping. • See unit nameplate.
Control system overheating.	<ul style="list-style-type: none"> • Heater not mounted correctly. • Heater mounted too close to ceiling. 	<ul style="list-style-type: none"> • Mounting angle 0°- 30°. Level left to right. • Observe clearance to combustibles.
Gas odor.	<ul style="list-style-type: none"> • Loose pipe connection. 	<ul style="list-style-type: none"> • Check connections. Tighten as necessary.
Heater cycles repeatedly.	<ul style="list-style-type: none"> • Heater located in drafty area. • Low gas pressure. • Thermostat located in drafty area. • Defective flame electrode or circuit board. 	<ul style="list-style-type: none"> • Relocate or shield from draft. • See Section 2.0, Gas Supply. • Relocate thermostat. • Replace electrode and/or circuit board.
No spark; no ignition.	<ul style="list-style-type: none"> • Lack of 24V incoming voltage. • Open high voltage wire. • Improper electrode gap. • Loose or open wire connection. • Poor or no equipment ground. • Unit in “safety lockout” mode. • Defective control module. 	<ul style="list-style-type: none"> • Check power supply. • Isolate and check resistance, replace if open. • See Ignition System specifications. • Check all wires, tighten or replace. • Check all connections, provide positive earth ground. • Interrupt power source, repeat trial for ignition. • Replace circuit board.
Heater lights, and “locks out” after approximately 10 seconds.	<ul style="list-style-type: none"> • Poor or no equipment ground. • Polarity is reversed. • Low gas pressure. • Electrode not sensing. • Heater mounted at incorrect angle. • Defective control module. 	<ul style="list-style-type: none"> • Check all connections, provide positive earth ground. • Correct wiring. • See Section 2.0, Gas Supply. • Relocate or replace if electrode is defective. • Mounting angle 0° - 30°. • Replace circuit board.
Spark is present. No main gas operation. Unit “locks out”.	<ul style="list-style-type: none"> • Gas valve in “OFF” position. • Defective gas valve. • Defective control module. 	<ul style="list-style-type: none"> • Turn to “ON” position. • Isolate and check for resistance, replace if reading open. • Replace circuit board.
Heater will not shut off.	<ul style="list-style-type: none"> • Defective thermostat or wiring. • Gas valve stuck or open. • High gas pressure. 	<ul style="list-style-type: none"> • Replace thermostat or repair wiring. • Replace gas valve. • See Section 2.0, Gas Supply.

5.0 Parts

Figure 5.1 • Heater Components

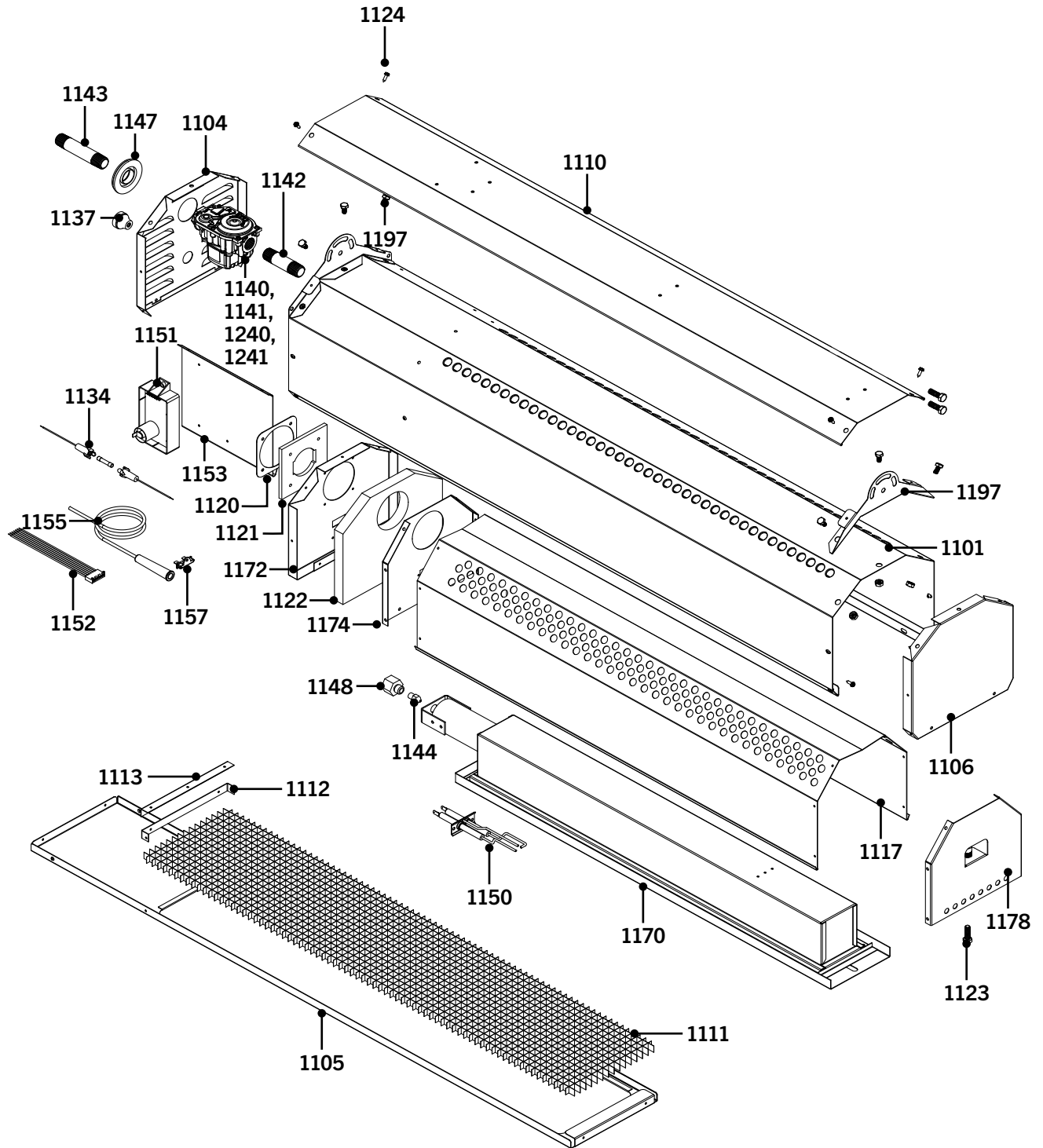

Chart 5.1 • Parts List

Part No.	Description
PH-1101 ¹	Exterior Casing
PH-1104 ¹	Control End Panel - A
PH-1105 ¹	Service Access Panel
PH-1106 ¹	End Panel
PH-1110 ¹	Rain Guard
PH-1111	Egg Crate
PH-1112	Egg Crate Locator
PH-1117	Reflector
PH-1120	Venturi Gasket Holder
PH-1121	Venturi Gasket
PH-1122	Insulation
PH-1123	5/16"-18x3/4" S.S. Hex Head Screw
PH-1124	1/4" x 1/2" Shoulder Sheet Metal Screw
PH-1134	In-Line Fuse
PH-1137	Thermostat Wire Grommet
PH-1140	Single Stage Gas Valve (Natural Gas)
PH-1141	Single Stage Gas Valve (Propane Gas)
PH-1142	3" Gas Pipe
PH-1143	4" Gas Pipe
PH-1144	Gas Orifice (Specify Model)
PH-1147	Rubber Inlet Grommet
PH-1148	1/2" to 1/8" NPT Adapter
PH-1150	Electrode
PH-1151	Circuit Board
PH-1152	Circuit Board Wiring Harness
PH-1153	Component Panel
PH-1155	High Voltage Wire w/ Boot
PH-1157	Thermal Fuse
PH-1170	Burner Assembly
PH-1172	Divider Panel
PH-1174	Reflector End - Ignition Side
PH-1178	Reflector End - Burner Support w/ Nutsert
PH-1197 ¹	Hanging Bracket Qty. 2
PH-1240	Two Stage Gas Valve (Natural Gas)
PH-1241	Two Stage Gas Valve (Propane Gas)

¹ Specify [B] Black or [S] Stainless Steel finish.

To order replacement parts call Detroit Radiant Products at: Voice: (586) 756-0950, Fax: (586) 756-2626
or visit our website: store.reverberray.com

6.0 Limited Warranty

6.0 Limited Warranty

One-Year Limited Warranty: Patio Heaters covered in this manual are warranted by Detroit Radiant Products Company to the original user against defects in workmanship or materials under normal use for one year after date of purchase. Any part which is determined to be defective in material or workmanship and returned to an authorized service location, as Detroit Radiant Products Company designates, shipping costs prepaid, will be, as the exclusive remedy, repaired or replaced at Detroit Radiant Products Company's option. For limited warranty claim procedures, see **Prompt Disposition** below. This limited warranty gives purchasers specific legal rights which vary from jurisdiction to jurisdiction.

Additional Limited Warranty: In addition to the above mentioned one-year warranty, Detroit Radiant Products Company warrants the original purchaser an additional four-year extension on the ceramic burner. This extension excludes electrical/purchased components.

General Conditions: The Company will not be responsible for labor charges for the analysis of a defective condition of the heater or for the installation of replacement parts. The warranties provided herein will not apply if the input of the heater exceeds the rated input at time of manufacturing or if the heater, in the judgment of the Company, has been subjected to misuse, excessive dust, improper conversion, negligence, accident, corrosive atmospheres, excessive thermal shock, excessive vibration, physical damage to the heater, alterations by unauthorized service personnel, operation contrary to the Company's instructions, or if the serial number has been altered, defaced, or removed. The Company shall not be liable for any default or delay in the performance of these warranties caused by contingency beyond its control, including war, government restriction or restraints, strikes, fire, flood, short or reduced supply of raw materials, or parts.

Limitation of Liability: To the extent allowable under applicable law, Detroit Radiant Products Company's liability for consequential and incidental damages is expressly disclaimed. Detroit Radiant Products Company's liability in all events is limited to and shall not exceed the purchase price paid.

Warranty Disclaimer: Detroit Radiant Products Company has made a diligent effort to provide product information and illustrate the products in this literature accurately; however, such information and illustrations are for the sole purpose of identification, and do not express or imply a warranty that the products are merchantable, or fit for a particular purpose, or that the products will necessarily conform to the illustrations or descriptions. Except as provided below, no warranty or affirmation of fact, expressed or implied, other than as stated in the **Limited Warranty** above is made or authorized by Detroit Radiant Products Company.

Product Suitability: Many jurisdictions have codes and regulations governing sales, construction, installation, and/or use of products for certain purposes, which may vary from those in neighboring areas. While Detroit Radiant Products Company attempts to assure that its products comply with as many codes as possible, it cannot guarantee compliance, and cannot be responsible for how the product is installed or used. Before purchase and use of a product, review the product applications, and all applicable national and local codes and regulations, and be sure that the product, installation, and use will comply with them.

Certain aspects of disclaimers are not applicable to consumer products: e.g., (a) some jurisdictions do not allow the exclusion or limitation of incidental or consequential damages, so the above limitation or exclusion may not apply to you; (b) also, some jurisdictions do not allow a limitation on how long an implied warranty lasts, consequently the above limitation may not apply to you; and (c) by law, during the period of this limited warranty, any implied warranties of implied merchantability or fitness for a particular purpose applicable to consumer products purchased by consumers, may not be excluded or otherwise disclaimed.

Prompt Disposition: Detroit Radiant Products Company will make a good faith effort for prompt correction or other adjustment with respect to any product which proves to be defective within limited warranty. For any product believed to be defective within limited warranty, first write or call dealer from whom the product was purchased. Dealer will give additional directions. If unable to resolve satisfactorily, write to Detroit Radiant Products Company at address below, giving dealer's name, address, date and number of dealer's invoice, and describe the nature of the defect. Title and risk of loss pass to buyer on delivery to common carrier. If product was damaged in transit to you, file claim with carrier.



© 2026 Detroit Radiant Products Co.
 21400 Hoover Road • Warren, MI 48089
 Phone: (586) 756-0950 Fax: (586) 756-2626
 www.detroitradiant.com • sales@drp-co.com

