

Detroit Radiant Products Co. Tube Heater General Manual

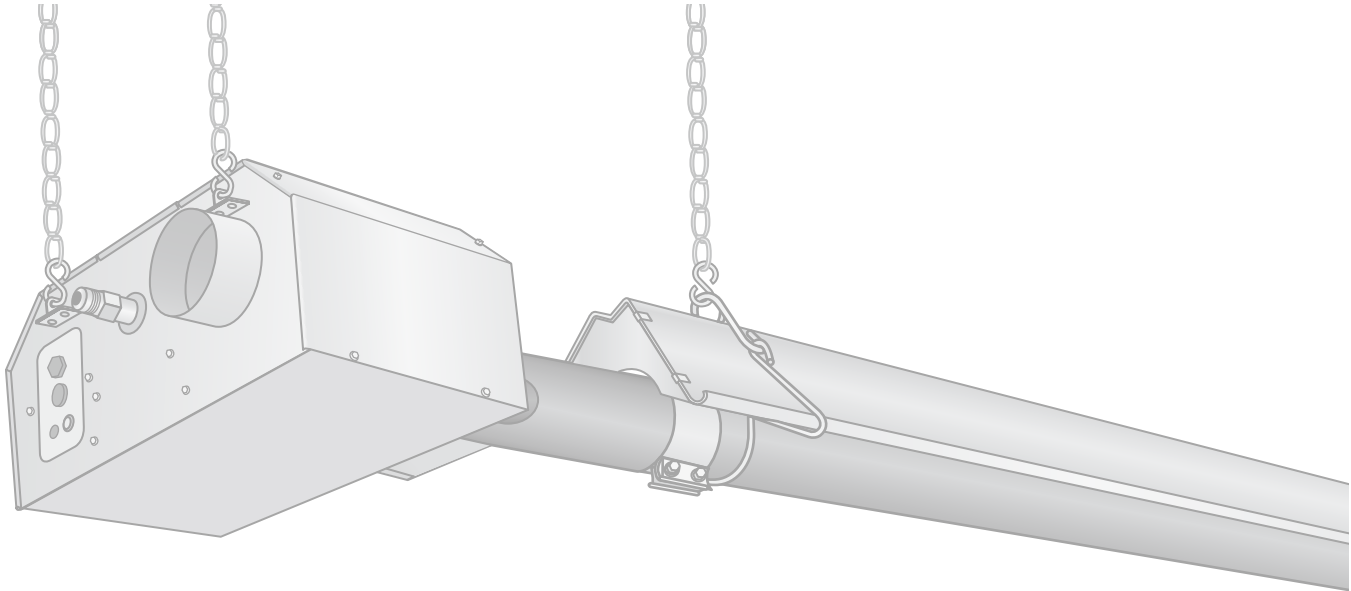

To be used in conjunction with Series 3 insert manuals.



⚠ WARNING



Improper installation, adjustment, alteration, service, or maintenance can cause property damage, injury, or death. Read and understand the installation, operating, and maintenance instructions thoroughly before installing or servicing this equipment.

This heater must be installed and serviced by trained gas installation and service personnel only. Failure to comply could result in personal injury, asphyxiation, death, fire, and/or property damage.



In locations used for the storage of combustible materials, signs must be posted to specify the maximum permissible stacking height to maintain the required clearances from the heater to the combustibles. Signs must either be posted adjacent to the heater thermostats or, in the absence of such thermostats, in a conspicuous location.

For Your Safety

If you smell gas:

- Do not try to light any appliance.
- Do not touch any electrical switch.
- Do not use any phone in your building.
- Immediately call your gas supplier from a neighbor's phone.
- Follow the gas supplier's instructions.
- If you cannot reach your gas supplier, call the fire department.

INSTALLER: Present this manual to the end user.

Keep these instructions in a clean and dry place for future reference.

Model#: _____ Serial #: _____
(located on rating label)

Form: LIOGT3-Rev. 10211
Print: 5M-05/26 (CDS)
Replaces: LIOGT3-3M-10/25 (CDS)

Contents

1.0 Introduction	3
Overview	3
Heater Components	3
2.0 Safety	4
Warning Symbols	4
Applications	4
Clearances to Combustibles	5
Safety Signs and Labels	5
Venting	6
Gas Supply	6
Heater Expansion	6
Standards, Certifications, and Government Regulations	7
3.0 Installation	9
Design Considerations and Prechecks	9
Hanger Placement and Suspension	12
Combustion / Radiant Tube Assembly	16
Optional Elbow or U-Bend Accessory Configuration	17
Burner Control Box Suspension	19
Reflector Assembly	20
Baffle Assembly and Placement	22
Final Heater Assembly	23
Venting	24
Vertical Venting (Category I)	26
Horizontal Venting (Category III)	28
Common Venting (Category I)	30
Common Venting (Category III)	31
Optional Unvented Operation	32
Combustion Air Requirements	32
Gas Supply	34
4.0 Operation	37
5.0 Maintenance	38
Troubleshooting Guide	39
6.0 Limited Warranty	40

WARNING

California Proposition 65

This product can expose you to chemicals including lead and carbon monoxide, which are known to the State of California to cause birth defects or other reproductive harm.

For more information, go to www.P65Warnings.ca.gov.

1.0 Introduction

Overview

The intent of this manual is to provide information regarding general safety, installation, operation, and maintenance of the tube heater. For complete assembly and installation instructions, use this Tube Heater General Manual in conjunction with the Series Insert Manual that accompanies this piece. You must read and understand the instructions and safety warnings in **both manuals** before installing the tube heater.

Heater Components*

Prior to installation, verify that the heater’s gas type and voltage (as listed on the rating plate) match that of your application. Also verify that you have received all heater contents included with your tube heater. Refer to the Series Insert for a list of the kit contents for your Series heater. Materials not included in the heater kit contents (e.g., screws, vent material, terminals, etc.) are the responsibility of the installer. Notify your product representative or Detroit Radiant Products of any discrepancy or missing kit contents prior to installing unit.

Figure 1.1 • Heater Components*

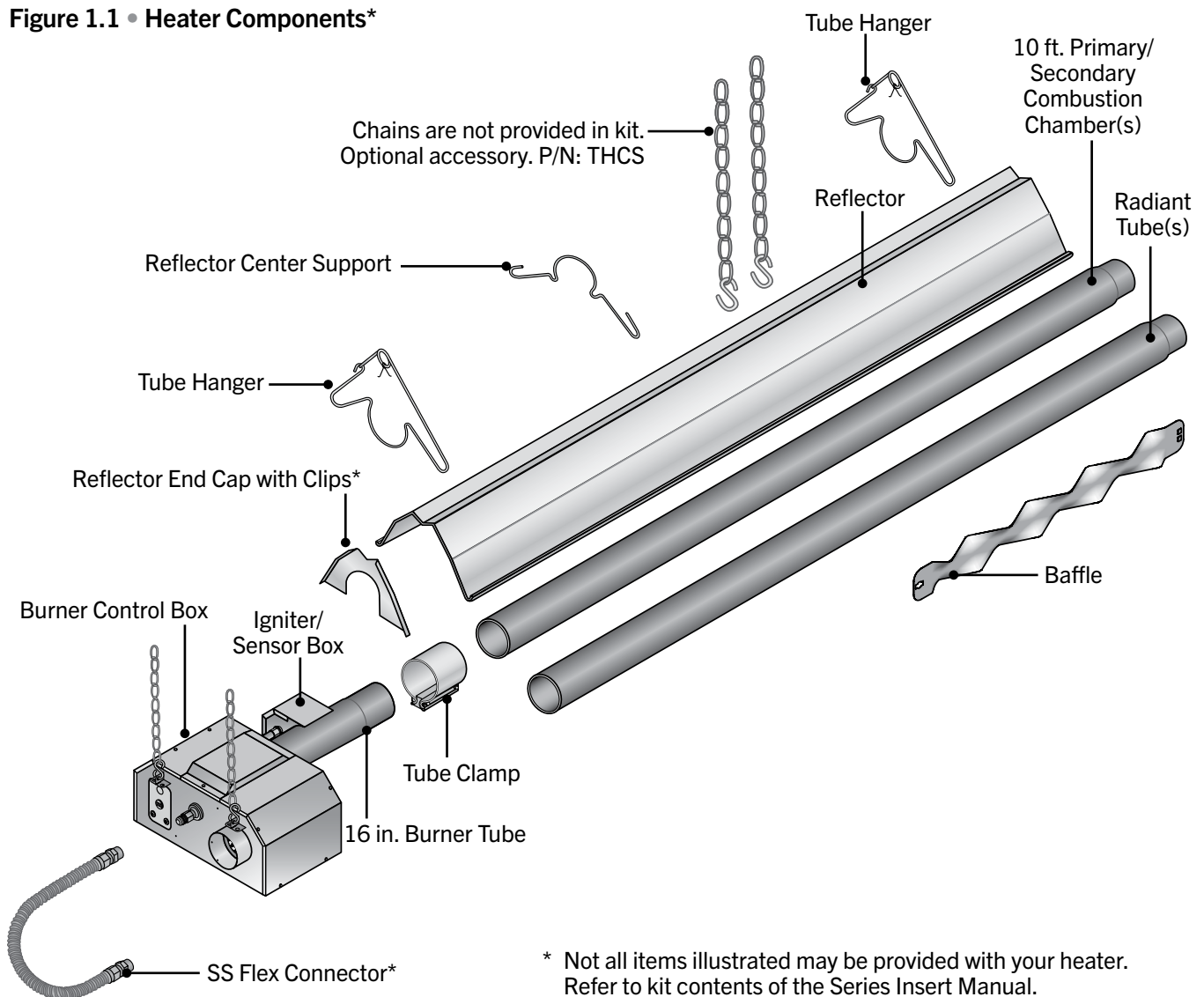

* Not all items illustrated may be provided with your heater. Refer to kit contents of the Series Insert Manual.

2.0 Safety

⚠ WARNING



Improper installation, adjustment, alteration, service, or maintenance can cause property damage, serious injury, or death. Read and understand the installation, operating, and maintenance instructions thoroughly before installing or servicing this equipment. Only trained, qualified gas installation and service personnel may install or service this equipment.

Warning Symbols

Safety is the most important consideration during installation, operation, and maintenance of the tube heater. You will see the following symbols and signal words when there is a hazard related to safety or property damage.

⚠ WARNING

Warning indicates a potentially hazardous situation which, if not avoided, could result in death or injury.

⚠ CAUTION

Caution indicates a potentially hazardous situation which, if not avoided, could result in minor or moderate injury.

NOTICE

Notice indicates a potentially hazardous situation which, if not avoided, could result in property damage.

Applications

This is not an explosion proof heater. No tube heater may be used in a Class 1 or Class 2 Explosive Environment. Consult your local fire marshal, insurance carrier, and other authorities for approval if the proposed installation is in question.

Commercial / Industrial

Unless otherwise indicated, tube heaters are designed and certified for use in industrial and commercial buildings, such as warehouses, manufacturing plants, aircraft hangars, and vehicle maintenance shops. For maximum safety the building must be evaluated for potential problems before installing the heating system. A critical safety factor to consider before installation is the clearances to combustibles.

⚠ WARNING

Not For Residential Use. Installation of a commercial tube heater system in residential indoor spaces may result in property damage, serious injury, or death.

Clearances to Combustibles

WARNING



Placement of explosive objects, flammable objects, liquids, and vapors close to the heater may result in explosion, fire, property damage, serious injury, or death. Do not store or use explosive objects, liquids, and vapor in the vicinity the heater.

Hazards:

For maximum safety the building must be evaluated for hazards before installing the heating system. Examples include, but are not limited to:

- Gas and electrical lines
- Combustible and explosive materials
- Chemical storage areas
- Areas of high chemical fume concentrations
- Provisions for accessibility to the heater
- Adequate clearances around air openings
- Combustion and ventilating air supply
- Vehicle parking areas
- Vehicles with lifts or cranes
- Storage areas with stacked materials
- Lights
- Sprinkler heads
- Overhead doors and tracks
- Dirty, contaminated environment

A critical safety factor to consider before installation is the clearances to combustibles. **Clearances to combustibles** is defined as *the minimum distance you must have between the tube surface, or reflector, and the combustible item*. Considerations must also be made for moving objects around the tube heater. The following is a partial list of items to maintain clearances from:

Combustible Items:

- Wood
- Paper
- Fabric
- Chemicals
- Paint
- Plastic
- Parked vehicles
- Gasoline
- Storage racks

Moving Objects:

- Overhead doors
- Vehicle lifts
- Cranes
- Hoists

When installing the tube heating system, the minimum clearances to combustibles for your series tube heater and system configuration must be maintained. These distances are shown in your Series Insert Manual and on the burner control box. If you are unsure of the potential hazards, consult your local fire marshal, fire insurance carrier, or other qualified authorities on the installation of gas fired tube heaters for approval of the proposed installation.

Safety Signs and Labels

It is important to provide warnings to alert individuals to potential hazards and safety actions. ANSI Z83.20 and CSA 2.34 require you to post a sign “specifying the maximum permissible stacking height to maintain the required clearances from the heater to the combustibles” near the heaters thermostat or, in the absence of such thermostats, in a conspicuous location. Contact Detroit Radiant Products Co. or an authorized dealer for Clearance Safety Limit Signs or for Clearance Safety Limit Tags (one tag is provided with each heater).

Safety warning labels must be maintained on the tube heater. Illustrations of the safety labels and their locations are pictured in the Series Insert Manual. In locations used for the storage of combustible materials, signs must be posted to specify the maximum permissible stacking height to maintain the required clearances from the heater to combustibles. Signs must either be posted adjacent to the heater thermostats or, in the absence of such thermostats, in a conspicuous location.

Venting

! WARNING



Insufficient ventilation may result in health problems, carbon monoxide poisoning, and death. Vent enclosed spaces and buildings according to national, state, provincial, and local codes.

This tube heater must be vented in accordance with national, state, provincial, and local codes along with the guidelines in the Detroit Radiant Tube Heater General (refer to pages 24 - 34) and applicable Series Insert Manual. In the United States refer to the latest edition of the ANSI Z223.1 (NFPA 54) Standard and in Canada refer to the latest edition of the CAN/CGA B149.1 Standard.

Gas Supply

! WARNING



Improperly connected gas lines may result in serious injury and death, explosion, poisonous fumes, toxic gases, or asphyxiation. Connect gas lines in accordance to national, state, provincial, and local codes.

The gas supply to the tube heater must be connected and tested in accordance with national, state, provincial, and local codes along with the guidelines in the Tube Heater General Manual (refer to pages 34-36) and Series Insert Manual. In the United States refer to the latest edition of the ANSI Z223.1 (NFPA 54) Standard and in Canada refer to the latest edition of the CAN/CGA B149.1 Standard.

Heater Expansion

! WARNING



Allowances **must** be made for the system to expand. Improper installation, adjustment, alteration, service, or maintenance can cause property damage, injury, or death.

A flexible gas connection of approved type is required. Connectors must be installed in one plane and without sharp bends, kinks, or twists.

The tube heater expands and contracts during operation. Follow the installation instructions to ensure allowances are made for this movement. To ensure your safety, and comply with the terms of the warranty, all units must be installed in accordance with these instructions.

Standards, Certifications, and Government Regulations

Installation of this tube heater must comply with all applicable local, state, and national specifications, regulations, and building codes. Contact the local building inspector and/or fire marshal for guidance.

In the absence of local codes, the installation must conform to the latest edition of:

United States: National Fuel Gas Code, ANSI Z223.1 (NFPA 54).

Canada: CAN/CGA B149.1 and .2, Canadian Electrical Code C22.1

Chart 2.1 • Standards and Code Installation Guidelines • Building Type

Building Type	Codes and Guidelines
<p>Public Garages / Maint. Facilities</p>	<p>Installation of this tube heater in public garages must conform to the following codes:</p> <p>United States: Standard for Parking Structures NFPA 88A (latest edition) or the Code for Motor Fuel Dispensing Facilities and Repair Garages NFPA 30A (latest edition).</p> <p>Canada: Refer to CAN/CGA B149.1: Installation Codes for Gas Burning Appliances and applicable Standards for Public Garages.</p> <p>Guidelines:</p> <ul style="list-style-type: none"> • Heaters must not be installed less than 8 ft. (2.4 m) above the floor. Minimum clearances to combustibles must be maintained from vehicles parked below the heater. • When installed over hoists, minimum clearances to combustibles must be maintained from the upper most point of objects on the hoist.
<p>Aircraft Hangars</p>	<p>Installation of this tube heater in aircraft hangars must be in accordance with the following codes:</p> <p>United States: Refer to Standard for Aircraft Hangars, ANSI/NFPA 409 (latest edition).</p> <p>In Canada: Refer to Standard CAN/CGA B149.1 and applicable Standards for Aircraft Hangars.</p> <p>Guidelines:</p> <ul style="list-style-type: none"> • In aircraft storage and servicing areas, heaters shall be installed at least 10 ft. (3 m) from above the upper surface of wings or of the engine enclosures of the highest aircraft that may be housed in the hangar. The measurement shall be made from the wing or engine enclosure, whichever is higher from the floor, to the bottom of the heater. • In areas adjoining the aircraft storage area (e.g., shops, offices) the bottom of heaters shall be installed no less than 8 ft. (2.4 m) above the floor. • Suspended or elevated heaters shall be located in spaces where they shall not be subject to damage by aircraft, cranes, movable scaffolding or other objects. <p>Provisions shall be made to assure accessibility to suspended tube heaters for recurrent maintenance purposes.</p>

Chart 2.2 • Standards and Code Installation Guidelines • Building Location

Building Location	Guidelines
High Altitude	<p>Guidelines:</p> <p>Installation of this tube heater is approved, without modifications, for elevations up to 6,000 feet (1,829 m) MSL (sea level) in the United States. Contact the factory for installations above these elevations.</p> <p>The type of gas appearing on the nameplate must be the type of gas used. Installation must comply with national and local codes and requirements of the local gas company.</p>
Non-Standard BTU Gas	<p>Guidelines:</p> <p>Unless otherwise noted on the rating plate, this infrared heater is designed and orificed to operate on standard BTU gas. Contact the factory if utilizing non-standard BTU gas.</p>

Chart 2.3 • Standards and Code Installation Guidelines • Building Aspect

Building Aspect	Codes and Guidelines
Electrical	<p>The tube heater must be electrically grounded in accordance with the following codes:</p> <p style="padding-left: 40px;">United States: Refer to National Electrical Code®, ANSI/NFPA 70 (latest edition). Wiring must conform to the latest edition of National Electrical Code®, local ordinances, and any special diagrams furnished.</p> <p style="padding-left: 40px;">Canada: Refer to Canadian Electrical Code CSA C22.1 Part 1 (latest edition).</p>
Venting	<p>Venting must be installed in accordance with the requirements within this manual and the following codes:</p> <p style="padding-left: 40px;">United States: Refer to NFPA 54/ANSI Z223.1 (latest edition), National Fuel Gas Code.</p> <p style="padding-left: 40px;">Canada: Refer to CAN/CGA B149.1 Installation Codes for Gas Burning Appliances.</p>

Applicable authorities governing the manufacturing or installation of this infrared heater include (but are not limited to) the following organizations:

- NFPA - National Fire Protection Association.
- ANSI Z83.20 - American National Standards Institute.
- NFPA 54/ANSI Z223.1 - National Fuel Gas Code.
- CSA - Canadian Standards Association.
- OSHA - Occupational Safety & Health Administration.
- IAS - International Approval Services.
- AGA - American Gas Association.
- CE - Certification of Europe.
- IRSC- Infrared Heater Safety Council.

NOTE: Refer to the Series Insert Manual for model specific certifications and approvals.

3.0 Installation

WARNING



Improper installation, adjustment, alteration, service, or maintenance can cause property damage, serious injury, or death.

Read and understand the installation, operating, and maintenance instructions thoroughly before installing or servicing this equipment.

Only trained, qualified gas installation and service personnel may install or service this equipment.

Design Considerations and Prechecks

Placement of infrared heaters is influenced by many factors. Aside from safety factors, considerations such as the number of heater or vent elbows that are allowed, maximum vent lengths, ducting of combustion air, and combining exhaust vents are a few examples.

To ensure a properly designed heating system, a layout should be developed for the correct placement of the burner control box, tubes, vents, and combustion air intake ducts. Inspect and evaluate the mounting conditions, vent locations, gas supply, and wiring.

When designing an infrared radiant heating system, consider the following:

- Has the building's heat loss been evaluated?
- Does the design meet the needs of the space?
- Have recommended mounting heights been observed?
- Have all clearance to combustibles situations been observed?
- Is the supply (burner) end of the heater located where more heat is required?
- Is it best to offset the heaters and/or rotate the reflectors towards the heat zone?
- Are extra guards, side shields, 'U' or 'L' reflector covers required?
- Does the heater require outside fresh air for combustion?
- Is the environment harsh or contaminated (requiring outside air for combustion)?
- Are wind barriers required? The effective infrared surface temperature of a person or object may be diminished with wind/drafts above 5 mph.
- Are chemicals or vapors a concern (requiring outside air for combustion or additional ventilation)?

IMPORTANT: Fire sprinkler heads must be located at an appropriate distance from the heater to avoid an inadvertent discharge. This distance may exceed the published clearances to combustibles. Certain applications may require the use of high temperature sprinkler heads or the relocation of the heaters.

CAUTION

Fire sprinkler systems containing propylene glycol, antifreeze, or other potentially flammable substances shall not be used in conjunction with this heater without careful consideration for and avoidance of inadvertent discharge hazards. For further information consult NFPA 13. Always observe applicable state and local codes.

When heated, materials high in hydrocarbons (solvents, paint thinner, mineral spirits, formaldehydes, etc.) can evaporate. This may result in odors or fumes being emitted into the environment. To correct this problem, clean the area and/or introduce additional ventilation. The heaters themselves, when installed and serviced in accordance with the installation manual, do not emit foul odors into the environment.

Design Scenario:

A tube heater system is being installed in a 90' (L) x 50' (W) x 14' (H) space. Two overhead doors are located at one end and an equipment storage area on one side. The calculated heat load is 400,000 BTU/h.

Figure 3.1 • Poor Design

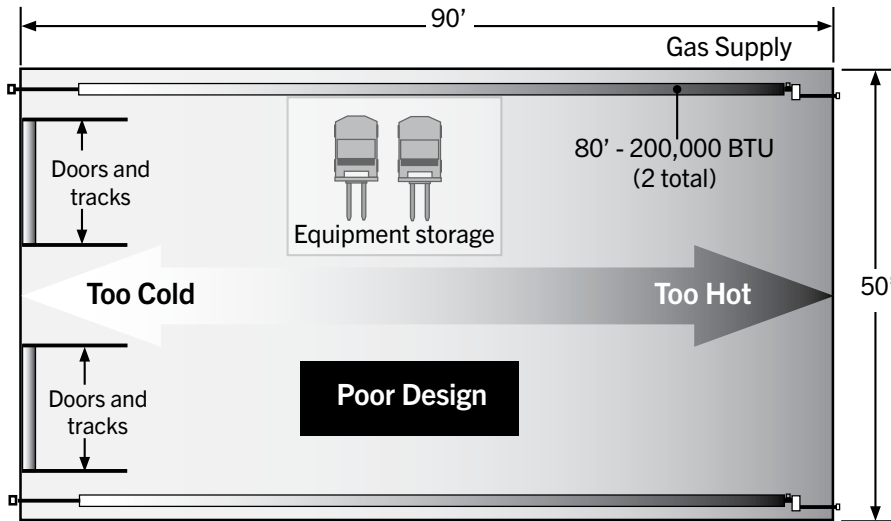

- Two burners (200,000 BTU each) are placed at one end, opposite the area of highest demand (e.g., overhead doors).
- Recommended mounting heights are not observed (see Chart 3.1).
- Produces an uneven heat distribution.

Figure 3.2 • Good Design

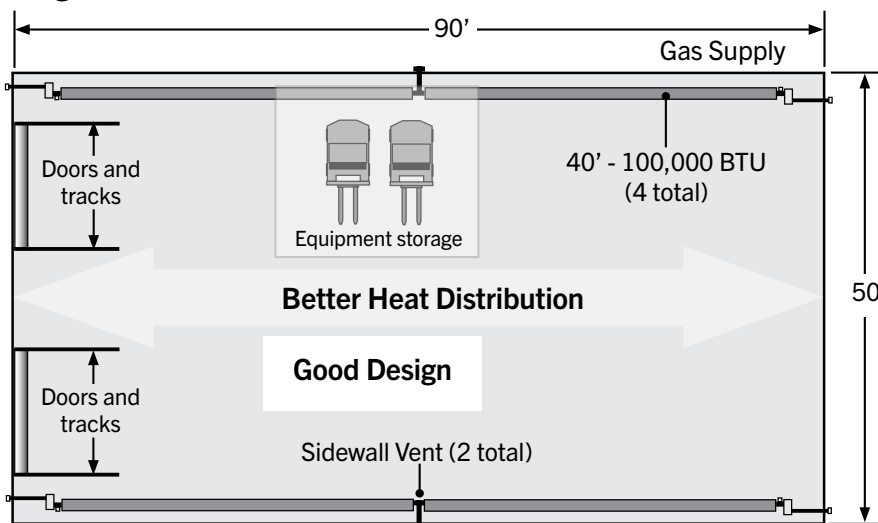

- Four burners (100,000 BTU each) are placed in each corner. Burner (hotter) ends direct heat to areas of highest heat demand.
- Recommended mounting heights have been observed.
- Distributes heat more evenly.

Chart 3.1 • Recommended Mounting Heights and Coverages

NOTE: This chart is provided as a guideline. Actual conditions may dictate variation for this data.

Model	BTU Range	Recommended Mounting Height (ft.)	Coverage Area Straight Config. (LxW)	Coverage Area U-Tube Config. (LxW)	Distance Between Heaters (ft.) Dimension A	Distance Between Heater Rows (ft.) Dimension B	Maximum Distance Between Heaters and Wall (ft.) Dimension C
20 ft.	50-65 MBH	10' - 16'	20' x 12'	12' x 12'	10' - 20'	20' - 40'	16'
	75-100 MBH	12' - 20'	22' x 15'	N/A	20' - 30'	30' - 50'	18'
30 ft.	50-65 MBH	10' - 16'	30' x 14'	17' x 13'	10' - 20'	20' - 40'	17'
	75-125 MBH	12' - 20'	33' x 18'	18' x 15'	20' - 30'	30' - 50'	20'
40 ft.	50-65 MBH	10' - 16'	40' x 16'	22' x 14'	10' - 20'	20' - 40'	20'
	75-125 MBH	12' - 20'	44' x 21'	23' x 17'	20' - 30'	30' - 50'	20'
	150-175 MBH	16' - 30'	45' x 26'	24' x 20'	30' - 40'	40' - 60'	25'
50 ft.	100-125 MBH	15' - 25'	55' x 24'	28' x 19'	20' - 30'	30' - 50'	25'
	150-200 MBH	16' - 30'	56' x 30'	29' x 23'	30' - 40'	40' - 60'	25'
60 ft.	125 MBH	16' - 25'	66' x 27'	33' x 21'	20' - 30'	30' - 50'	25'
	150-200 MBH	17' - 40'	67' x 34'	34' x 26'	30' - 40'	40' - 60'	25'
70 ft.	175-200 MBH	17' - 40'	78' x 38'	39' x 29'	30' - 40'	40' - 60'	30'
80 ft.	200 MBH	18' - 45'	89' x 42'	44' x 32'	30' - 40'	40' - 60'	30'

Factory recommended mounting heights are listed as a guideline. If infrared heaters are mounted to low or to high, they may result in discomfort or lack of heat. Detroit Radiant Products Company generally recommends observing the recommended mounting heights to optimize comfort conditions. However, certain applications such as spot heating, freeze protection, outdoor patio heating, or very high ceilings may result in the heaters being mounted outside of the factory recommended mounting heights.

Figure 3.3 • Mounting Height Dimensions (see Chart 3.1 for measurements)

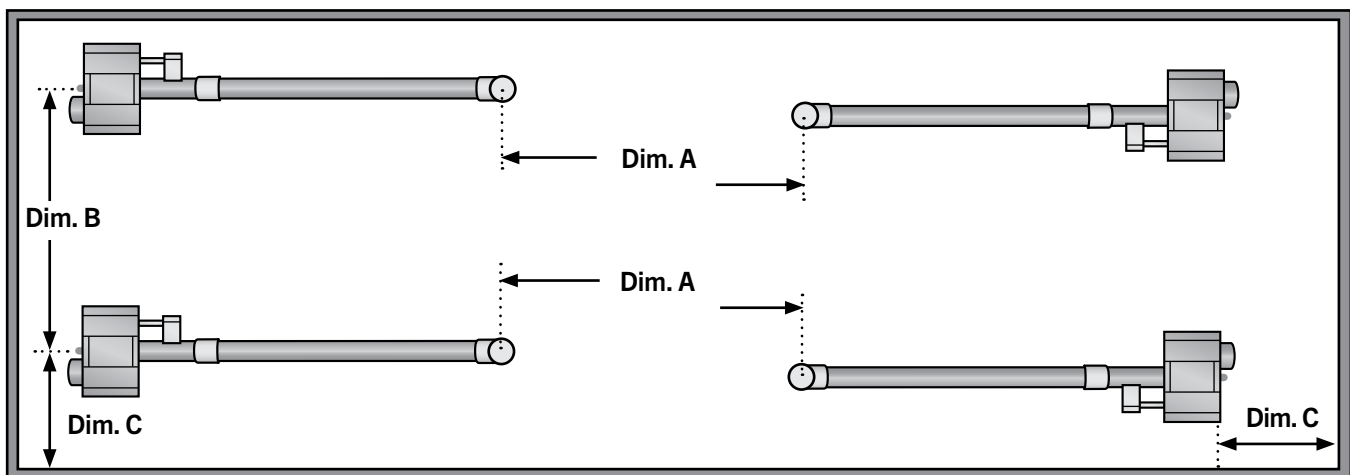

Note: Dimensions A, B, & C are based upon heaters hung at the factory recommended mounting height.

Hanger Placement and Suspension

WARNING



Improper suspension of the tube heater may result in collapse and being crushed. Always suspend from a permanent part of the building structure that can evenly support the total force and weight of the heater.



Failure to maintain minimum clearance to combustibles may result in fire and/or explosion, property damage, serious injury, or death. Always maintain minimum clearances and post Clearance Safety Limit (P/N: PLQ) where needed.

Suspension of the heater must conform to applicable codes referenced in the Safety section and these instructions.

- ① Lay all radiant tubing out in the following order. Position tubes in approximate location (see Figure 3.4).
 - 10 ft. primary combustion chamber.
 - If applicable, a secondary 10 ft. aluminized treated combustion chamber (150-200 MBH models only). Refer to the Specifications Chart in the Series Insert Manual to determine if a second combustion chamber is required for your model heater.
 - Radiant emitter tubes.

Important! 150,000-200,000 BTU/h models must use the 10 ft. titanium alloy treated combustion chamber as the first tube downstream of the burner control box. The combustion chamber has an orange identification sticker located on the swaged end of the tube.

Stainless Steel Heaters must use the 409 series stainless steel combustion chamber as the first tube downstream of the burner control box.

- ② Mark locations for hanging points.

NOTE: If the available hanging points do not allow for the recommended spacing then additional hangers (P/N: TP-19B) may be necessary.

- The spacing between the burner control box mounting brackets and the first hanger should be approximately 2'-4".
- The space between the first two hangers placed on the first tube, should be approximately 8'-10".
- The space between hangers thereafter, one per tube, should be approximately 9'-8".

Figure 3.4 • Heater Mounting Layout

NOTE: A sticker identifying the combustion chamber(s) is located on the swaged end of the tube(s). (For 150,000-200,000 BTU/h models and all heaters with 409 stainless steel tubes only.)

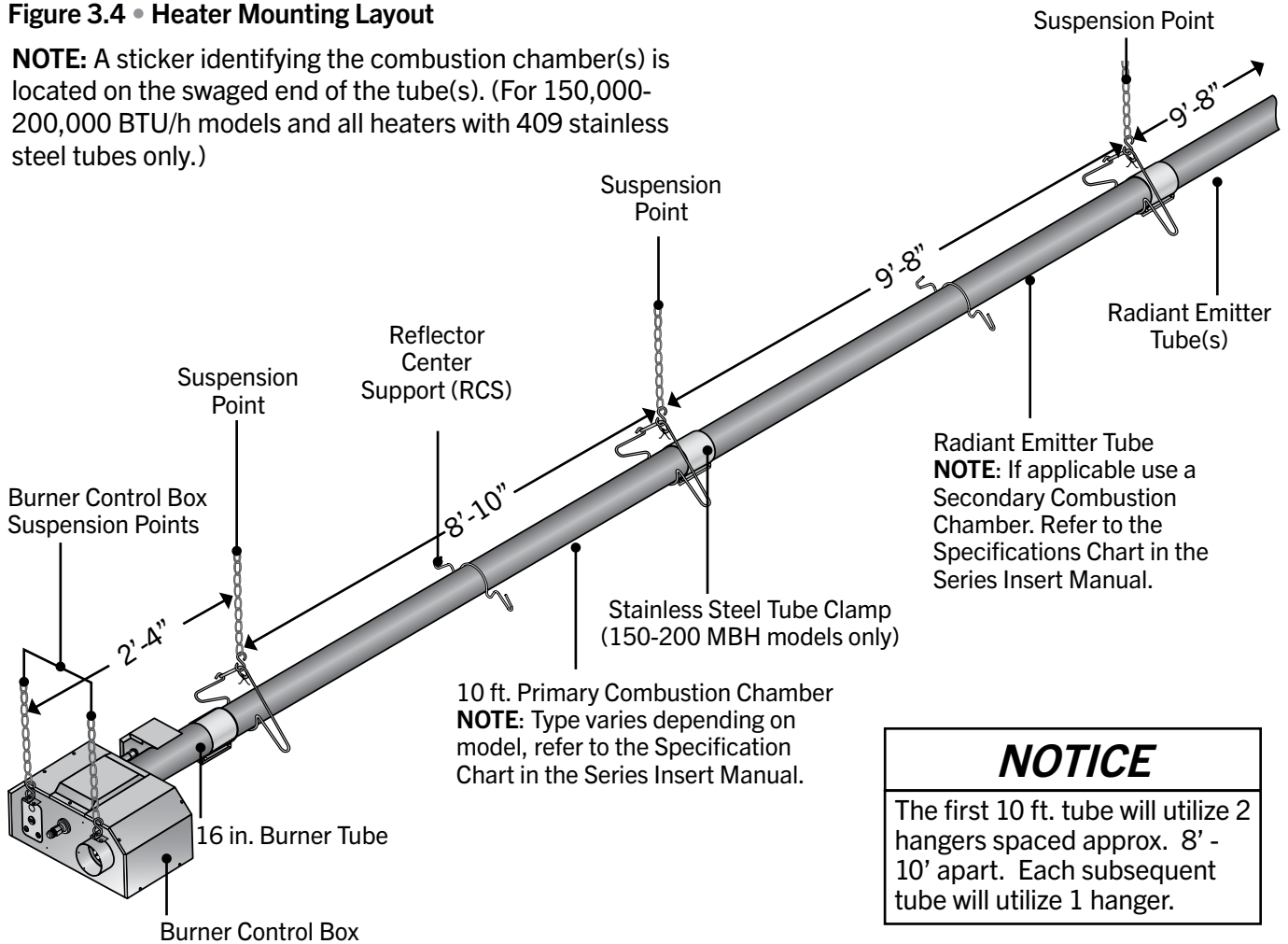

Chart 3.2 • Heater Mounting Requirements and Weights

Model	Dimension* Straight Configuration	Suspension Points	Control Box Stabilizer	Shipping Weight	Stainless Steel Ship Weight	Chain Set Qty. Straight	Chain Set Qty. w/TF1B	Optional Brass Knuckle (P/N: BK)	Optional Single Mount Bracket (P/N: SMB) U configurations only
20 ft.	21'-9" / 261"	3	2	120 lbs.	145 lbs.	5	6	3	2
30 ft.	31'-5" / 377"	4	2	160 lbs.	195 lbs.	6	8	4	3**
40 ft.	41'-1" / 493"	5	2	190 lbs.	235 lbs.	7	8	5	3
50 ft.	50'-9" / 609"	6	2	235 lbs.	290 lbs.	8	10	6	4**
60 ft.	60'-5" / 725"	7	2	265 lbs.	330 lbs.	9	10	7	4
70 ft.	70'-1" / 841"	8	2	300 lbs.	375 lbs.	10	12	8	5**
80 ft.	79'-9" / 957"	9	2	330 lbs.	405 lbs.	11	12	9	5

* Refer to page 18 for U-bend configuration dimensions.

** Model requires 5EA-SUB accessory package when installing in a U-shaped configuration.

- 3 Prepare mounting surface and, if necessary, weld blocks and/or drill holes (see figure 3.5).
NOTE: The burner control box and radiant tubes should be in straight alignment and level.
- 4 Fasten beam clamp, screw hook, or other type of suspension anchor to hanging point.
- 5 **IF USING CHAINS:** Attach and close S-hook (P/N: S-HOOK) and #1 double-loop chain (P/N: THCS) to anchor. Check that it is securely attached. **NOTE:** Threaded rod and turnbuckles may be used.
- 6 **IF USING GRIPPLE:** (P/N: THGHxx) Pass the loop end of the cable through the hook. Thread the other end through the loop, the locking fastener, the hanger, and back up through the locking fastener. Adjust to appropriate length. **NOTE:** Threaded rod and turnbuckles may be used.
- 7 Attach hangers to chains. Adjust chain lengths until radiant tubing is level and equal weight distribution is achieved. Chains must be straight up and down. Do not install chains at an angle as this can result in tube warping or separation.

Figure 3.5 • Mounting the Hangers

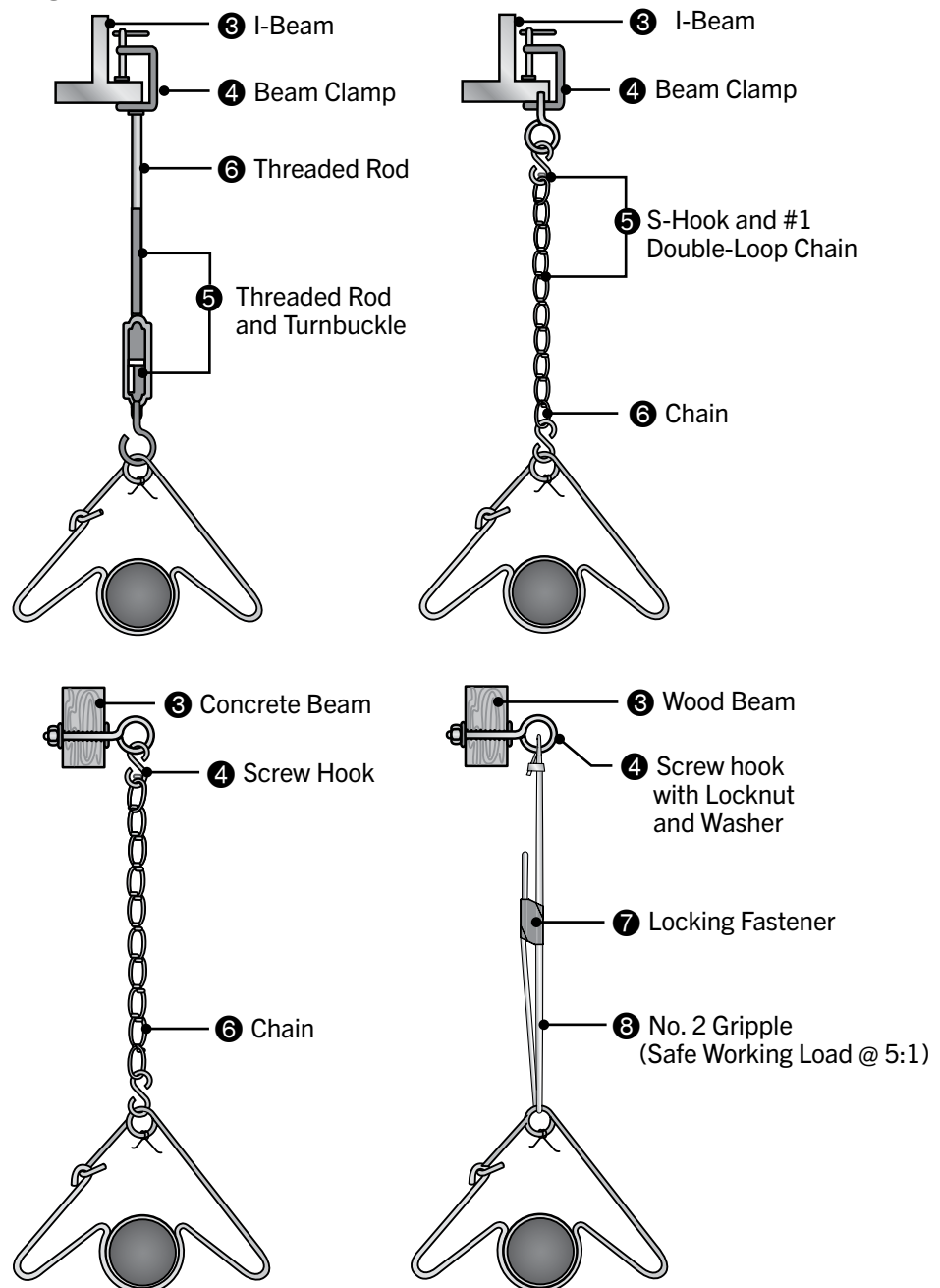
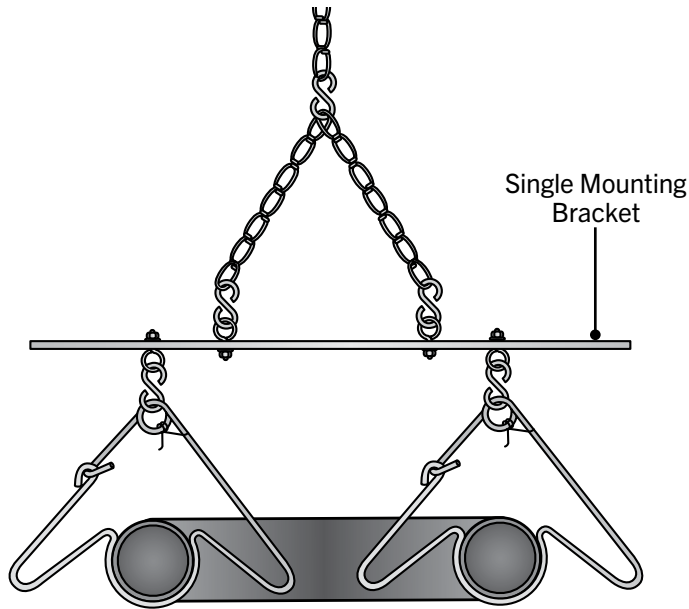
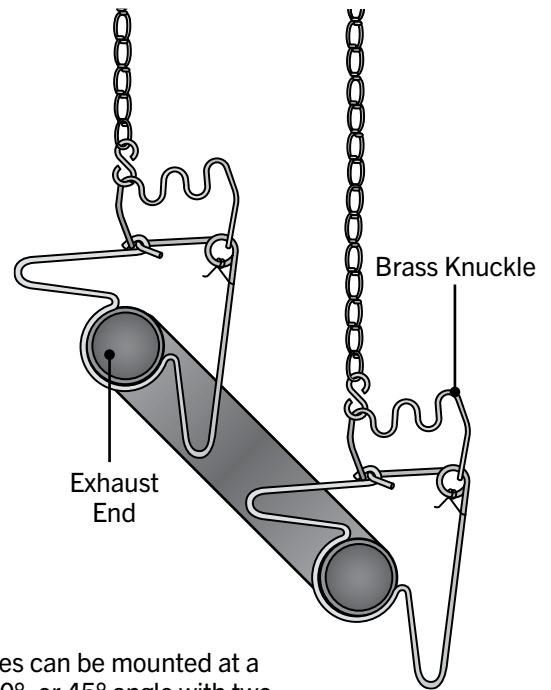

Figure 3.6 • U-Tube Hanger Mounting Options



U-Tubes can be mounted from a single suspension point using a Single Mounting Bracket (P/N: SMB) with five S-hooks and #1 double-loop chains.



U-Tubes can be mounted at a 15°, 30°, or 45° angle with two suspension points, using two Brass Knuckle (P/N: BK) fittings, #1 double-loop chains, and S-hooks.

Figure 3.7 • Angled Hanger Mounting Options

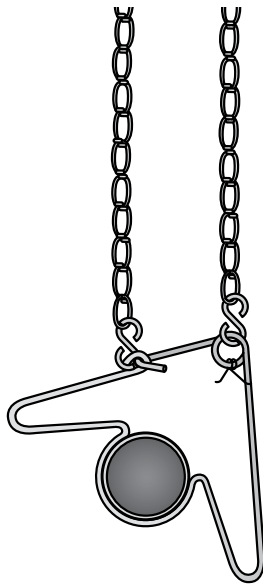

For 45° hanging angle, use two S-hooks and two #1 double-loop chains.

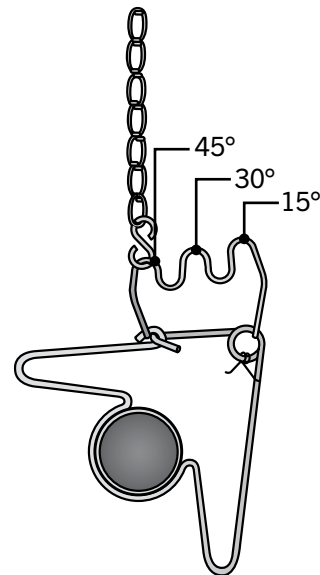

For variety of hanging angles, use the Brass Knuckle (P/N: BK) fitting with a #1 double-loop chain and S-hook.

Combustion / Radiant Tube Assembly

To install the radiant tubes:

- 1 Place tubes in hangers with the welded seam facing downward and the swaged end of the tube towards the exhaust end of the heater system (see figure 3.8). **NOTE:** The first 10 ft. combustion tube will utilize two (2) hangers and each subsequent tube will utilize one (1) hanger.

Refer to the Series Insert Manual for tube installation sequence. Place the combustion chamber as the first tube connected to the burner control box. These tubes have an identification sticker on the swaged end.

Figure 3.8 • Attach Hangers

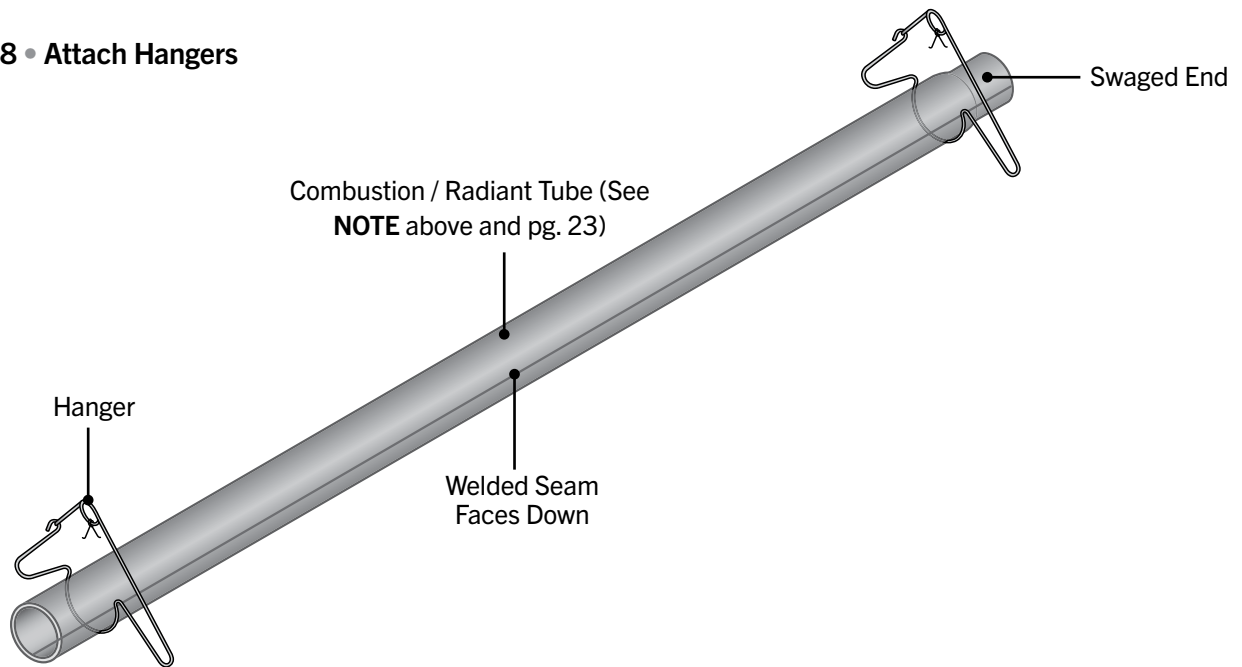

- 2 Slide tube clamps onto radiant tubes (see figure 3.9).

Figure 3.9 • Attach Tube Clamps

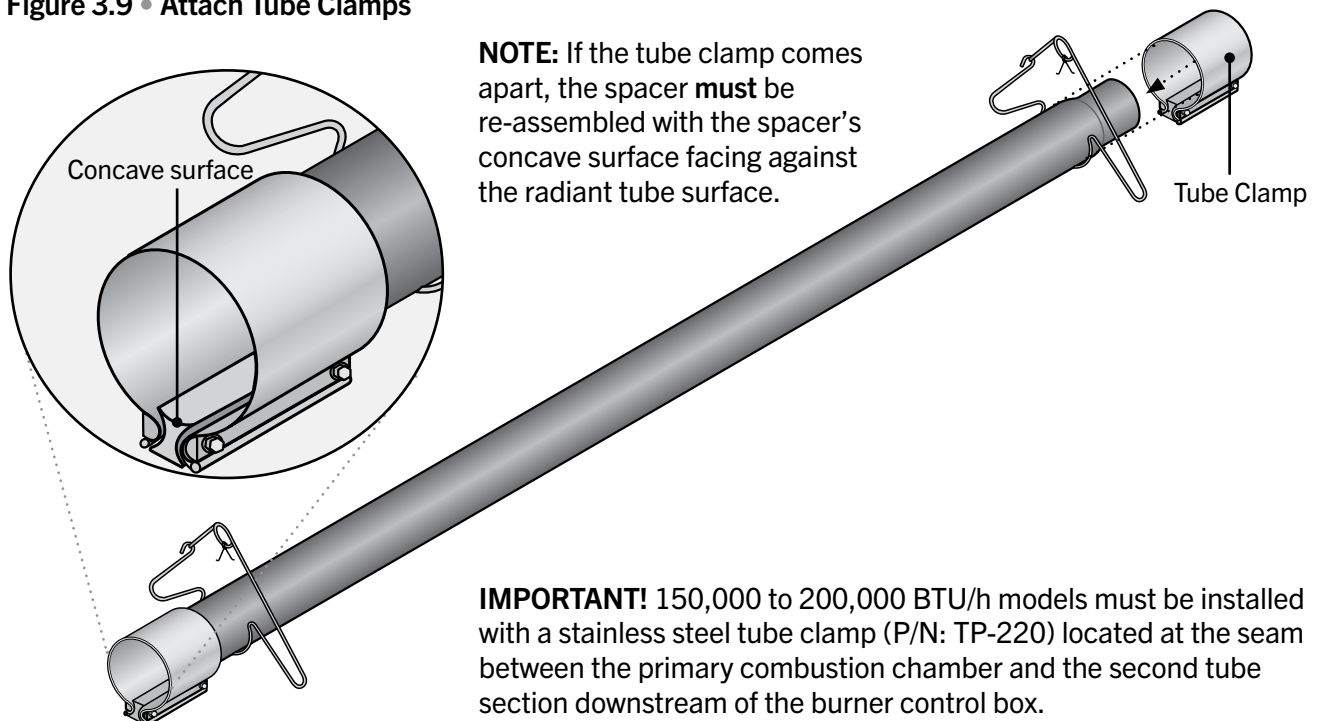

- ③ Slip-fit the radiant tube sections together until tightly connected (install the swaged end of each tube towards exhaust end). **NOTE:** If it is difficult to mate the tubes, they may be installed incorrectly.
- ④ Center tube clamps over the seam where two radiant tube sections connect. If necessary, rotate tube clamps so they will not interfere with the reflector end caps during expansion and contraction of the heater.
- ⑤ Tighten tube clamp bolts to secure. When proper compression is obtained (40-60 ft-lbs. torque) the tube seam will create a visible mark on the tube clamp. **NOTE:** Excessive torque may damage the tube clamp.
- ⑥ Determine the location of the burner control box and note the placement of the mounting chains.

Figure 3.10 • Tube Connections

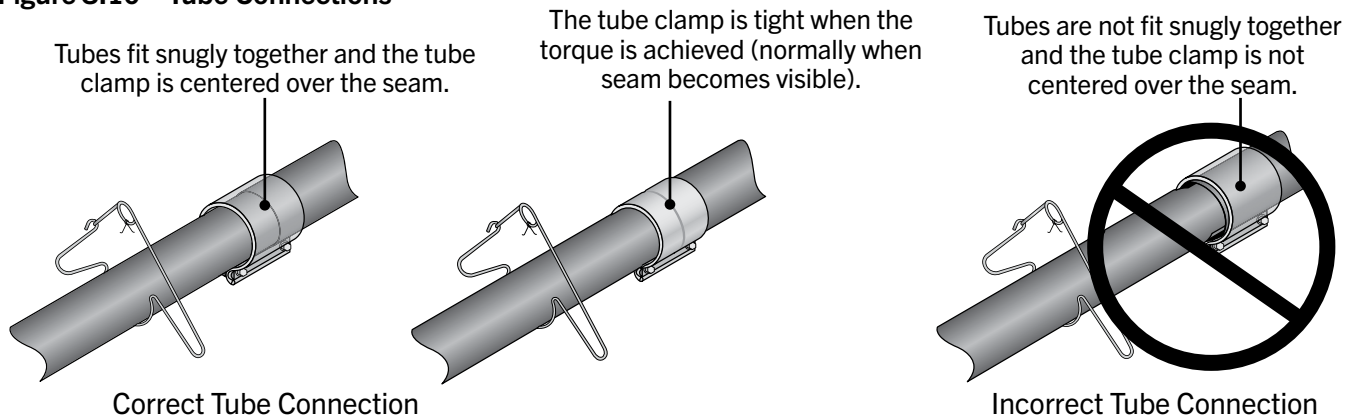

Optional Elbow or U-Bend Accessory Configuration

A 90° elbow or 180° U-bend accessory fitting may be installed in the radiant tube heating system. Refer to Chart 3.3 for minimum distance requirements from the burner control box. Consult factory for CNG applications.

When Installing an Elbow or U-Bend Accessory Fitting:

- The top clearance of an uncovered (no reflector) elbow or U-bend accessory fitting to combustibles is 18 inches.
- If operating the heater unvented, separate the intake air to the heater from its exhaust products a minimum of 4 feet; further separation may be necessary. Combustion air may also be supplied.
- A maximum of two 90° elbows or one 180° U-bend can be installed on a heater.
- Omit one 36 inch section of turbulator baffle. Refer to Baffle Assembly section.

Figure 3.11 • Optional Tube Connections

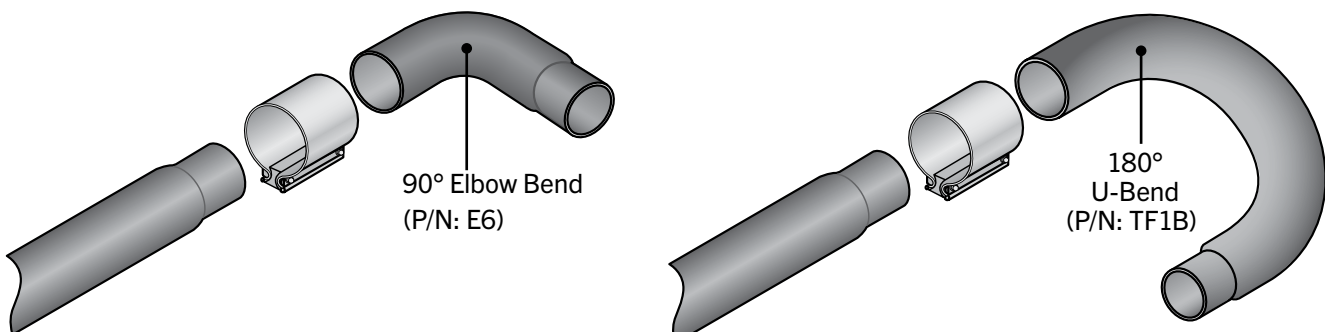

Figure 3.12 • Elbow and U-Bend Clearances

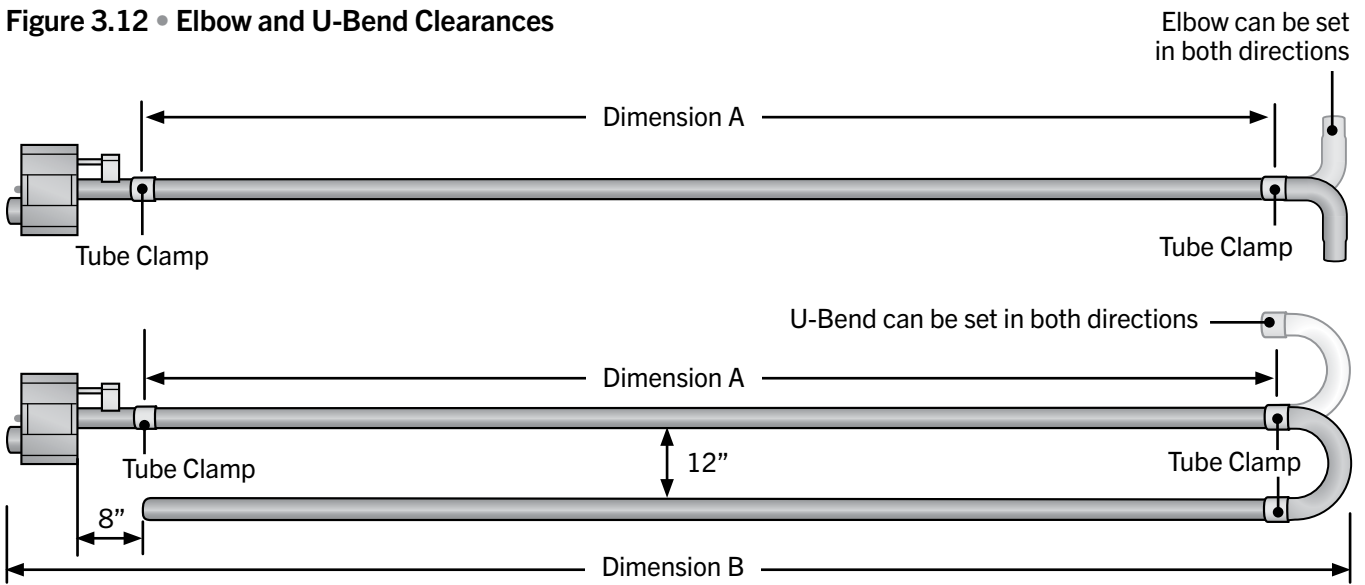

Figure 3.13 • U-Bend and Elbow Dimensions

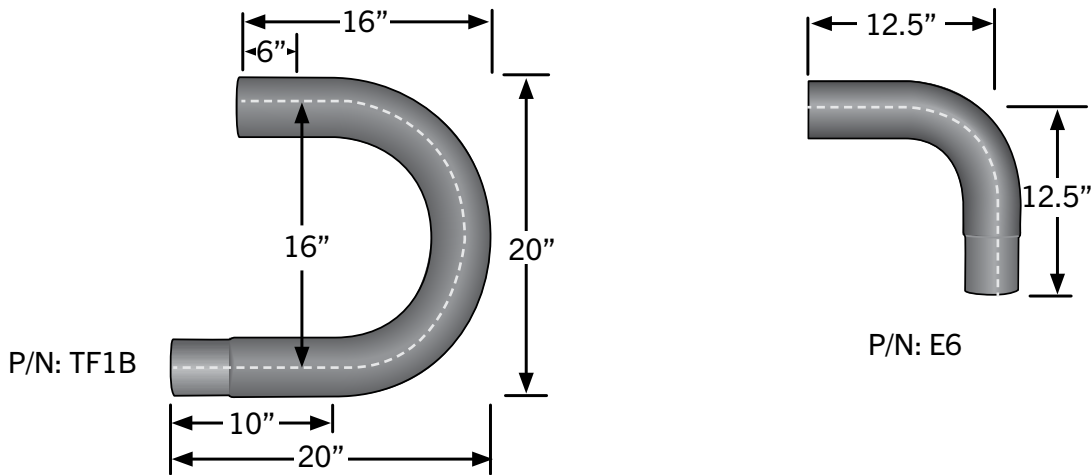

Chart 3.3 • Minimum Distance From Burner Control Box to Elbow or U-Bend Accessory Fitting*

Models (MBH)	Dimension A
50 - 100	10 ft.
110 - 125	15 ft.
130 - 175	20 ft.
200	25 ft.

*Consult factory for CNG applications.

Chart 3.4 • Overall Dimensions for Heaters Configured With U-Bend (P/N: TF1B)

Model	Dimension B	Notes
20 ft.	13' - 1" / 157"	N/A
30 ft.	17' - 9" / 213"	Requires P/N: 5EA-SUB *
40 ft.	22' - 9" / 273"	N/A
50 ft.	27' - 5" / 329"	Requires P/N 5EA-SUB *
60 ft.	32' - 5" / 389"	N/A
70 ft.	37' - 3" / 447"	Requires P/N 5EA-SUB *
80 ft.	42' - 1" / 505"	N/A

* 5EA-SUB may only be ordered at the time of heater production. Field corrections require two (2) TR-60 packages.

Reflector Assembly

To install the reflectors (see figure 3.16):

- ❶ Attach the reflector center supports onto radiant tubes. **NOTE:** On models equipped with a single reflector center support, place at mid-point of primary combustion chamber.
- ❷ Slide each reflector section through the hangers beginning with the first 10 foot tube. The reflector should begin approximately 1 inch from the igniter box. Adjust the reflector tension spring (if applicable) into the V-groove on the top of the reflector. The reflectors should overlap approximately 4 inches.
- ❸ To prevent the reflectors from shifting, secure the reflector sections together using sheet metal screws, except at the expansion joint (see Chart 3.6). When securing joints on reflectors which are rotated on an angle from horizontal, secure joint only on top side of reflector to allow for sufficient heater expansion and contraction. **NOTE:** Installer to supply sheet metal screws.
- ❹ Attach reflector end caps (if applicable), with polished finish inward, to each end of the reflector run. Secure with clips.

Reflectors and reflector accessories direct infrared energy to the floor level. The reflector assembly depends on the heater configuration, proximity to combustibles, and space surrounding the heater. Before you begin assembly, determine if the use of reflector accessories are necessary (see Chart 3.5).

Figure 3.16 • Reflector Assembly

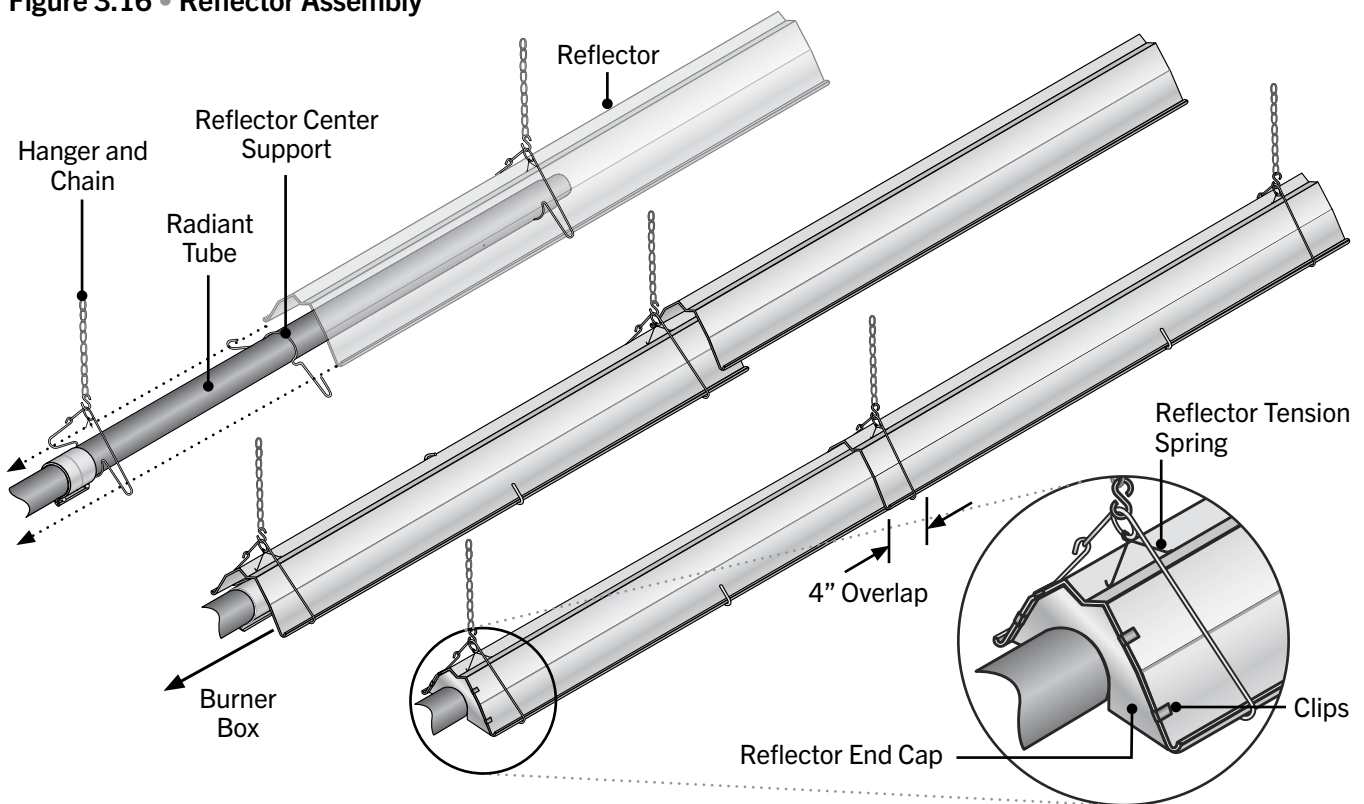

Figure 3.17 • Width of Installed Reflector - Top View

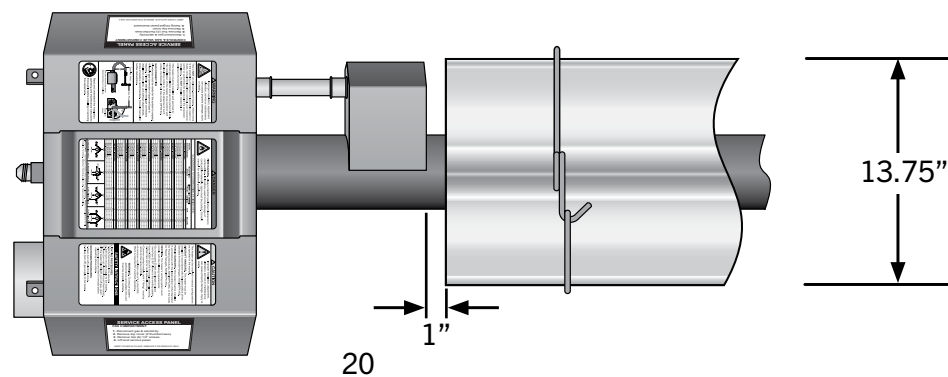

Chart 3.5 • Common Optional Accessories

Reflector Assembly	Description	Part Number
Elbow Reflector*	90° bend, highly polished aluminum reflector elbow designed to fit atop one elbow accessory fitting.	RE
U-Reflector*	180° bend, highly polished aluminum reflector U-Bend designed to fit atop one U-Bend accessory fitting.	RU
Side Shield Extension**	Highly polished side shield extension used to direct infrared rays downward, away from sidewalls and combustibles.	SSE
Protective Guard	Used to prevent debris or objects from becoming lodged between the radiant tube and reflector. Required when mounting heaters below 8 feet.	PG

* Reflectors cannot be rotated when used with a reflector elbow (RE), U-shaped reflector (RU), or side shield (SSE).

** Refer to the Clearances to Combustibles chart in the Series Insert Manual for minimum distances to combustibles when side shield extension(s) are used.

Additional accessory options are listed in the Detroit Radiant Products Company Tube Heater Accessory Guide or online at www.detroitradiant.com.

Figure 3.18 • Reflector Shield Accessories

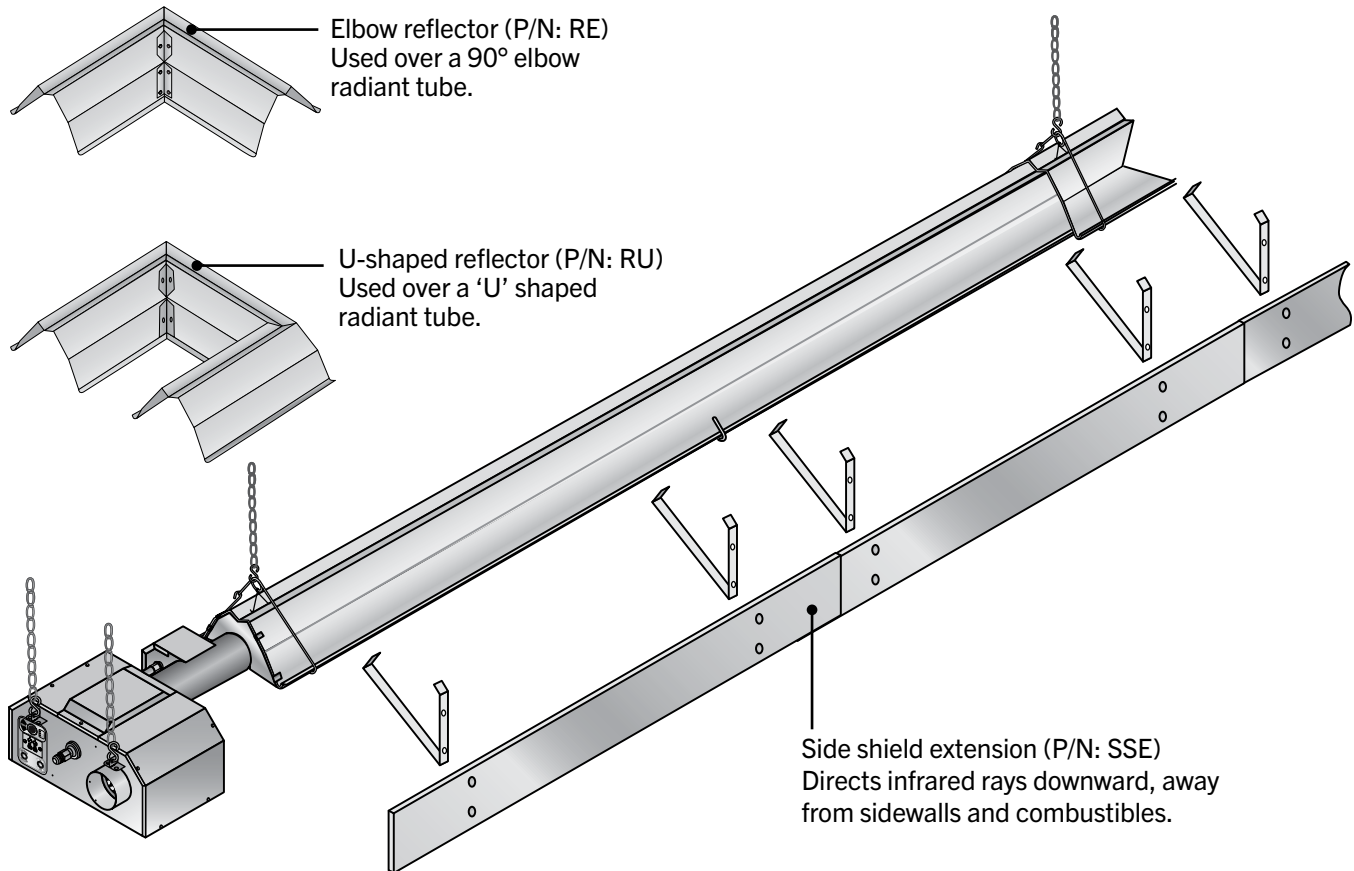

Baffle Assembly and Placement

Different models and inputs utilize specific baffle lengths. Remove all enclosed baffle sections from box and retain with applicable heater. Reference shipping label for proper baffle size.

To assemble the baffles: NOTE: Baffles may be inserted into the tube while being assembled.

- ❶ Determine the number of baffles needed for your model number. **Remove one 36 inch baffle section if heater is fitted with an elbow (P/N: E6) or U-bend (P/N: TF1B) accessory.**
- ❷ Orient the baffle tabs at a 90° angle to the baffle keyhole (see figure 3.19).
- ❸ Insert one baffle tab into keyhole and slide completely to one side until both baffle tabs appear in the keyhole.
- ❹ Adjust the tabs to the center of the keyhole and rotate the baffle 90° to lock the baffle sections together.
- ❺ Repeat this process with all remaining baffle sections to complete assembly.

Figure 3.19 • Assembling the Baffles

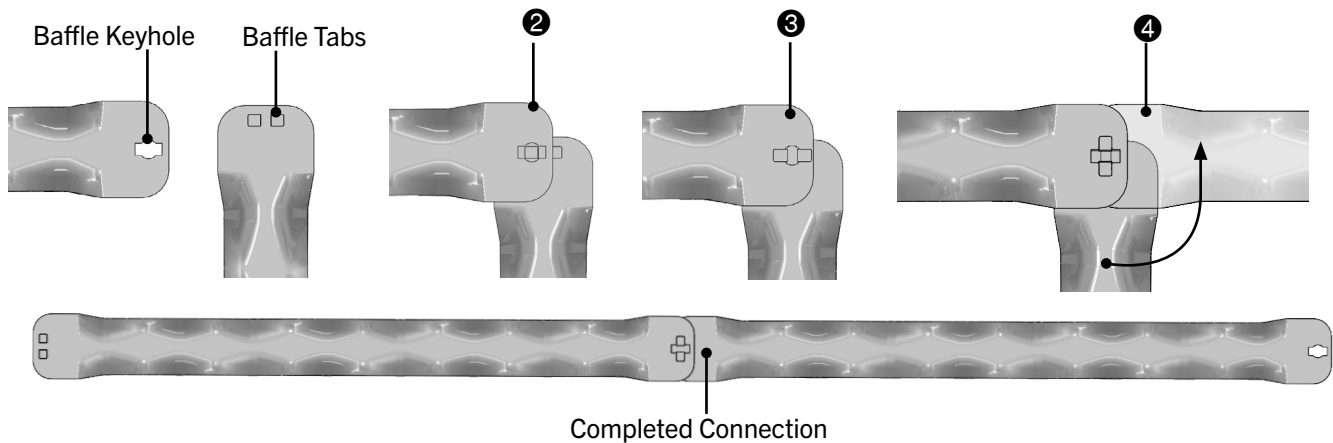

To insert the baffles:

- ❶ Insert baffles with the keyhole end first.
- ❷ Rotate baffle assembly so that it is in the **vertical position**.
- ❸ Slide baffle assembly into the last radiant tube section, furthest from the burner control box.
NOTE: Baffle assemblies longer than 10 ft. will continue to be fed into next tube section. **When the heater is configured with a 'U' or 'L' shaped accessory fitting** It may be necessary to cut the baffle in two sections. In this case, place as much baffle as possible downstream of the fitting and the remainder just before the fitting.

Figure 3.20 • Inserting the Baffles

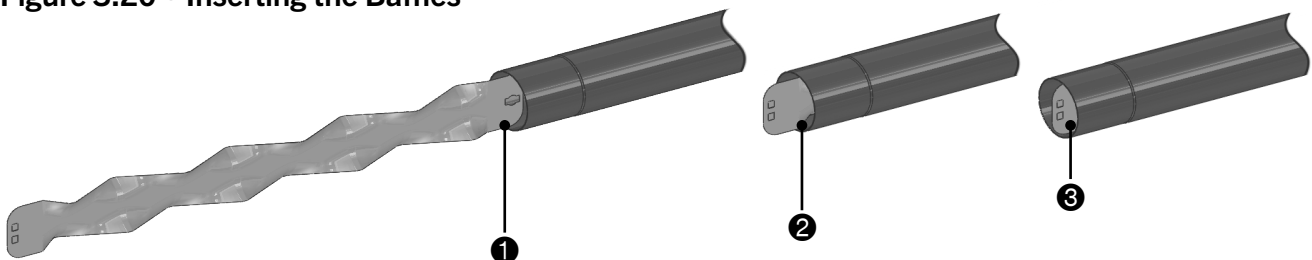

IMPORTANT: Baffle assembly must be flush with the end of the last tube section and in the vertical position.

Final Heater Assembly

Chart 3.6 • Tube Installation Sequence, Baffle Location, and Secured Joints for Reflectors

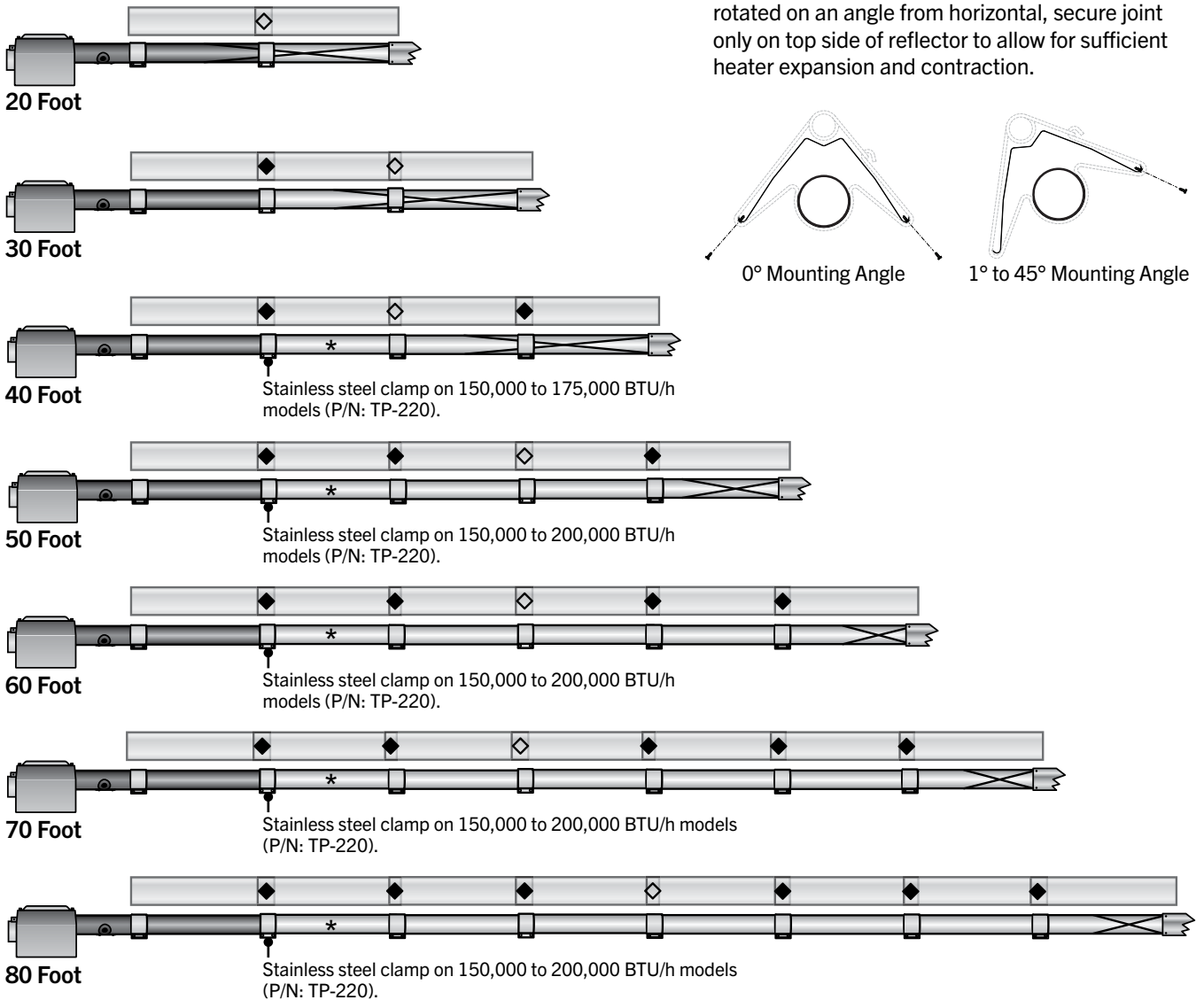

Key	
	Burner Control Box w/16 in. Burner Tube
	Expansion Joint on Reflectors
	Secured Joint on Reflectors (see note)
	Primary Combustion Chamber with Clamp
	Radiant Tube Exchanger with Clamp
	Baffle Location (Refer to Series Manual for baffle quantity.)
	Secure vent material to exchanger with three #8 sheet metal screws. Seal with high temperature silicone sealant. Do not use tube clamp.
* A secondary combustion chamber is installed as the second tube downstream from the burner control box on 150,000 to 200,000 BTU/h models, excluding HL3 and DX3L series. Refer to the Series Insert Manual for installation requirements.	

Venting

The heating system must be vented as described here to properly direct flue gases from the unit to the outside atmosphere. The venting can terminate vertically through the roof (up) or horizontally through a sidewall (sideways).

Follow these guidelines and all applicable codes for all models prior to installing the vent material. Local codes may vary.

In the absence of local codes:

United States: Refer to NFPA 54/ANSI Z223.1 (latest edition), National Fuel Gas Code.

Canada: Refer to CAN/CGA B149.1 and B149.2 Installation Codes for Gas Burning Appliances.

! WARNING



Gas-fired heaters must be vented. A built in power exhauster is provided. Additional external power exhausters are not required or permitted.

Insufficient ventilation and/or improperly sealed vents may release gas into the building which could result in health problems, carbon monoxide poisoning, or death. Improper venting may result in fire, explosion, injury, or death.

! WARNING

Do not vent this appliance through a masonry chimney.

Do not use dampers in the heater vent pipe.

Single wall vent pipe must not pass through any unoccupied attic, inside wall, concealed space, or floor.

Un-insulated single wall vent pipe must not be used outdoors for venting appliances in regions where winter design temperature is below freezing.

Replacing Existing Equipment

If the heater is replacing existing equipment and using an existing vent system, inspect the venting for proper size and horizontal pitch as directed in these instructions and the latest edition of the National Fuel Gas Code, ANSI Z223.1 (NFPA 54) or CSA B149.1 Installation Code. When an existing Category I heater is removed or replaced, the original venting system may no longer be sized to properly vent the attached appliances.

Determine that there is no blockage or restriction, leakage, corrosion, or other deficiencies that can cause hazards. The vent pipe should be corrosion-resistant galvanized steel of a thickness that meets the National Fuel Gas Code. Minimum thickness for connectors varies depending on the pipe diameter. Never vent the heating system with PVC or plastic pipe.

! WARNING



If replacing an existing heater, vents may require re-sizing. Improperly sized venting systems can result in vent gas leakage or condensation. Refer to the National Fuel Gas Code ANSI Z223.1 (NFPA 54) or CSA B149.1 - latest edition. Failure to follow these instructions can result in serious injury or death.

General Venting Requirements

The venting system for the heating system may terminate horizontally through a sidewall or vertically through the roof, and may be individually or commonly vented. Configuration of the vent termination determines the category type. Heaters must be installed in accordance with the requirements of this section, as well as the requirements of its category determination, as described in this manual. To determine your applications category type, review “Vertical Venting (Category I)” and “Horizontal Venting (Category III)” sections of this manual.

All Applicable Model Requirements:

- Exhaust vent pipe must be 4 inch nominal size unless common venting. For vent pipe size when common venting, see pages 30-31.
- Use vent pipe material that is corrosion-resistant galvanized steel of a thickness that meets the National Fuel Gas Code.
- Do not exceed a maximum vent length of 20 ft. with two elbows, 25 ft. with one elbow, or 30 ft. with no elbows.
- Maintain a minimum vent length of 3 feet.
- Maintain a minimum of 12 inches of straight pipe from the flue outlet before any directional changes are made in the venting system.
- Have all vent pipe seams or connectors sealed with high temperature silicone sealant approved for at least 550°F (field supplied) and fastened together with at least three (3) corrosion resistant sheet metal screws (field supplied).
- Maintain a 6 inch clearance around all single wall vent pipe from any combustible materials. For double-wall type B vent or Duravent PVP venting, follow the vent manufacturer’s clearances to combustibles.
- The equivalent length for a 4 inch 90° elbow is 5 feet.
- Avoid using more than two 90° directional changes in the venting system.
- Suspend and secure all horizontal runs in a manner consistent with local codes and in such a way that the vent system is supported to prevent sagging.
- Vent termination must maintain a minimum distance of 6 feet from any mechanical air supply inlet.
- The vent terminal must be installed to prevent any blockage by snow and protect building material from degradation by flue gases.
- Consult NFPA ANSI Z223.1 Gas Vent Termination criteria for vents that terminate on a roof pitch that exceeds 9:12.
- **Canada:** Vents must terminate a minimum of 3 feet from a window or door that may be opened, and a non-mechanical air supply inlet or combustion air inlet into the building.

When possible, avoid venting through an unconditioned space. Venting through an unconditioned space promotes condensation. When venting through an unconditioned space is unavoidable, or if the unit is installed in an area that is prone to condensation, insulate venting runs greater than 5 feet to minimize the production of condensation. Inspect for leakage prior to insulating the venting and only use insulation that is non-combustible with a temperature rating of not less than 550°F. Install a tee fitting at the low point of the vent system and provide a drip leg with a clean out cap as shown in Figure 3.21.

When venting pipe passes through a combustible interior wall or floor, a metal thimble with a diameter 4 inches greater than the vent pipe diameter must be used. If there is 6 feet or more of vent pipe prior to passing through the combustible wall or floor, then the metal thimble need only be 2 inches greater than the vent pipe diameter. If a metal thimble is not used, all clearances to combustibles from the vent pipe must be 6 inches. When permitted, type B vent or Duravent PVP venting may be used for the last section of vent pipe to reduce the required clearances to combustibles when passing through a combustible wall or floor. When using type B vent or Duravent PVP venting, follow the manufacturer's recommended clearances to combustibles. Any material used to close or insulate the opening must be non-combustible.

Vertical Venting (Category I)

An appliance that operates with a non-positive vent static pressure and with a vent gas temperature that avoids excessive condensate production in the vent is said to be 'Category I'. The heater is considered a Category I appliance if the venting system meets all of the following criteria:

- The vent system terminates vertically (up).
- The length of the horizontal portion of the vent run is less than 75% of the vertical rise length. (e.g.- If the vertical vent height is 10 feet, the horizontal run is less than 7 ½ feet).
- The vent terminates a minimum of 5 feet above the vent connection on the unit.
- Horizontal venting sections of the vent pipe must be installed with an upward slope from the appliance at a pitch of ¼ inch per foot.

For vertical vent termination, the venting must comply with all parts of this section, in addition to the requirements of the general venting.

Category I (Vertical) venting is venting at a non-positive pressure. An appliance vented as a Category I is considered a fan-assisted appliance and the vent system does not have to be 'gas tight'. It is recommended that the venting system is installed with a tee, drip leg, and clean-out cap as shown in Figure 3.21.

Vent Locations and Clearances:

- Separate air intake duct from vent pipe by a minimum of 4 feet by placing vent pipes higher than adjacent air intake ducts.
- Utilize a listed type B vent termination cap.
- The vent terminal must extend a minimum of 2 feet above the roof.
- Vent caps should be located a minimum of 2 feet away from adjoining structures.

All vertically vented heaters that are Category I must be connected to a chimney or vent complying with a recognized standard, or lined masonry (or concrete) chimney with a material acceptable to the authority having jurisdiction. Venting into an unlined masonry chimney is not permitted. Refer to the National Fuel Gas Code and page 25 of this manual.

Use a listed vent terminal to reduce down drafts and moisture in the vent.

Figure 3.21 • Rooftop Venting - Side View

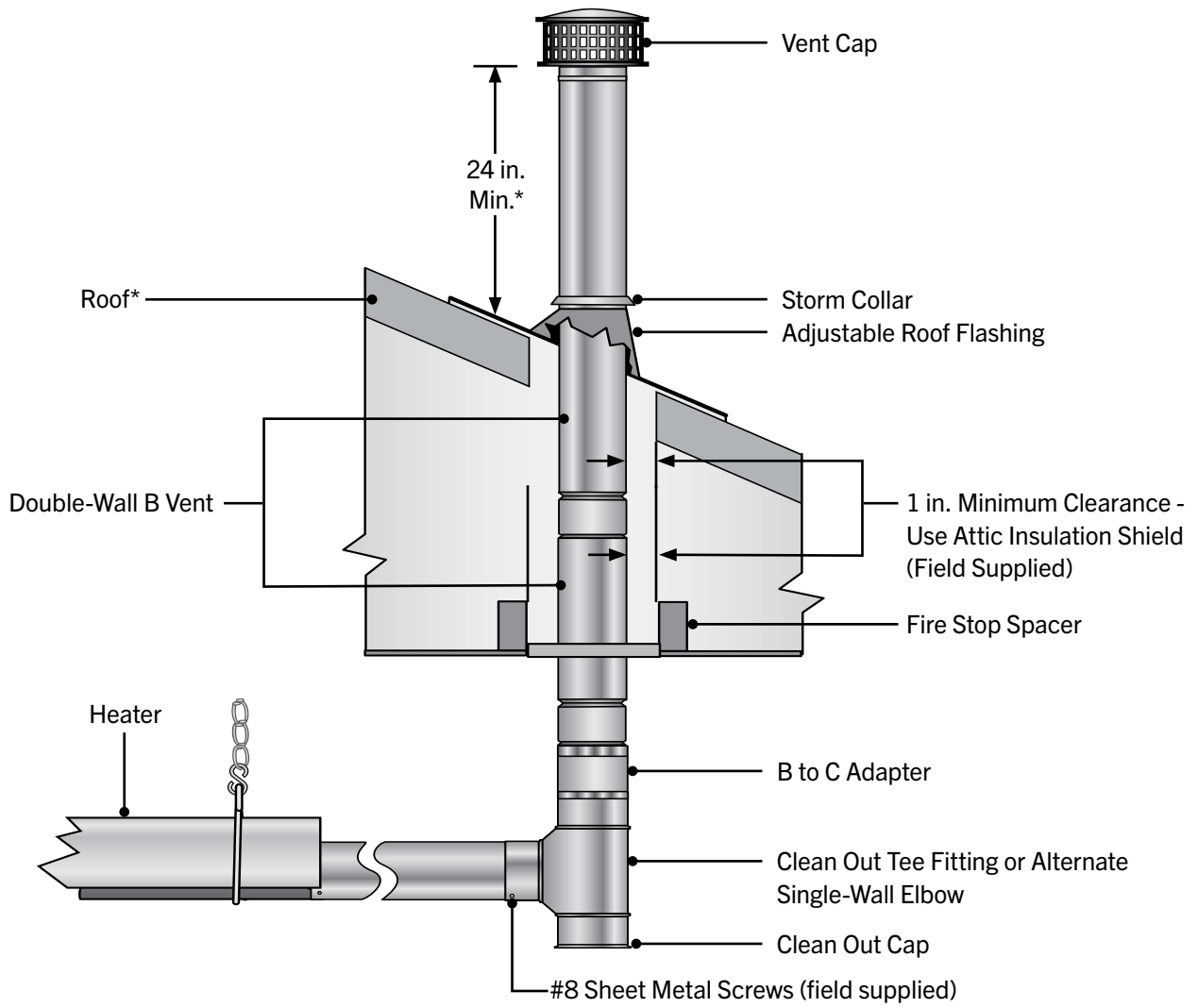

*Consult the NFPA ANSI Z223.1 Gas Vent Termination criteria if roof pitch exceeds 9:12

Horizontal Venting (Category III)

An appliance that operates with a positive vent static pressure and with a vent gas temperature that avoids excessive condensate production in the vent is said to be “Category III”. The heater is considered a Category III appliance if the venting system meets all of the following criteria:

- The vent system terminates horizontally (sideways).
- The vent terminates vertically, but the length of the horizontal portion of the vent run exceeds 75% of the vertical rise length. (e.g.- If the vertical vent height is 10 feet, the horizontal run is greater than 7 ½ feet).
- The vent terminates below 5 feet above the vent connection on the unit.
- Horizontal venting sections of the vent pipe must be installed with a downward slope from the appliance at a pitch of ¼ inch per foot.

Vent enclosed spaces and buildings according to the guidelines in this manual and applicable national, state, provincial, and local codes.

The venting system must be provided by the installer and should be comprised of single-wall venting materials with a thickness of no less than 26 gauge. All joints must be sealed with a high temperature silicone sealant approved for at least 550°F using a minimum bead of ¼” x ¼”, and fastened with at least three corrosion resistant #8 sheet metal screws evenly spaced.

One continuous section of double-wall B vent or Duravent PVP vent may be used to pass through a combustible wall or barrier, or the installer may continue to use single-wall vent provided a combustible wall thimble is used which provides adequate clearances to combustibles.

All horizontal Category III vents must be terminated with a Simpson-Duravent sidewall vent cap (P/N: SWD-4 for 4” venting and P/N: SWD-6 for 6” venting).

IMPORTANT! Once all silicone sealant has fully cured according to manufacturer’s instructions, the installer must perform a leak test on the complete venting system. A solution of soap and water may be used to test the venting inside the occupied space. Once the installer has verified the venting system is completely sealed and free of leaks, the heater may be placed into operation.

Vent Locations and Clearances:

- Vent must terminate a minimum of 4 feet below, 4 feet horizontally from, or 1 foot above any window or door that may be opened or gravity air inlet into the building.
- Vent must terminate a minimum of 3 feet above any forced air inlet that is located within 10 feet.
- The bottom of the vent terminate must be located a minimum of 12 inches above grade level and must extend beyond any combustible overhang. Vents adjacent to public walkways must terminate a minimum of 7 feet above grade level.
- The vent cap must be a minimum of 6 inches from the sidewall of the building.
- Vent must be a minimum of 36 inches below or extend beyond any combustible overhang.

Never join two sections of double wall vent pipe within one horizontal vent system as it is impossible to verify that inner pipes are completely sealed.

Figure 3.22 • Sidewall Venting Requirements

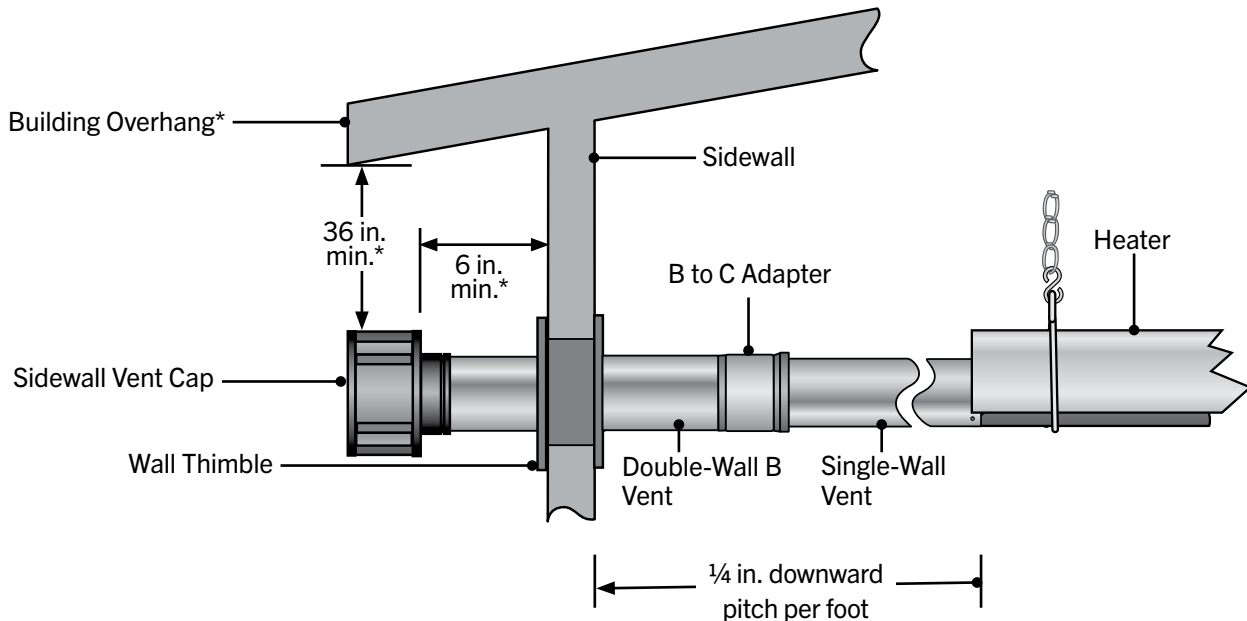

*Vent must extend beyond any combustible overhang if the vent is less than 36 in. below the combustible overhang.

Common Venting (Category I)

The common vent system and all attached appliances must be Category I and must be on the same control device.

The vent connector should be routed in the most direct route from the units to the common vent.

Where two or more vent connectors enter a common gas vent or chimney flue, the smaller connector shall enter at the highest level consistent with the available head room or clearance to combustible material.

Restrictions within the common vent such as elbows should be minimized. Each elbow installed within the common portion of the vent carrying system reduces the maximum common vent capacity by 10%. Refer to NFPA 54 IFEC tables 11.2 and 11.3 for capacity.

The vent connector capacities allow for the use of two 90° directional changes. For each additional required elbow, the vent connector capacity is reduced by 10%.

The common vent cross sectional area must be equal to or greater than the largest vent connector cross sectional area.

Figure 3.23 • Common Rooftop Venting - Side View

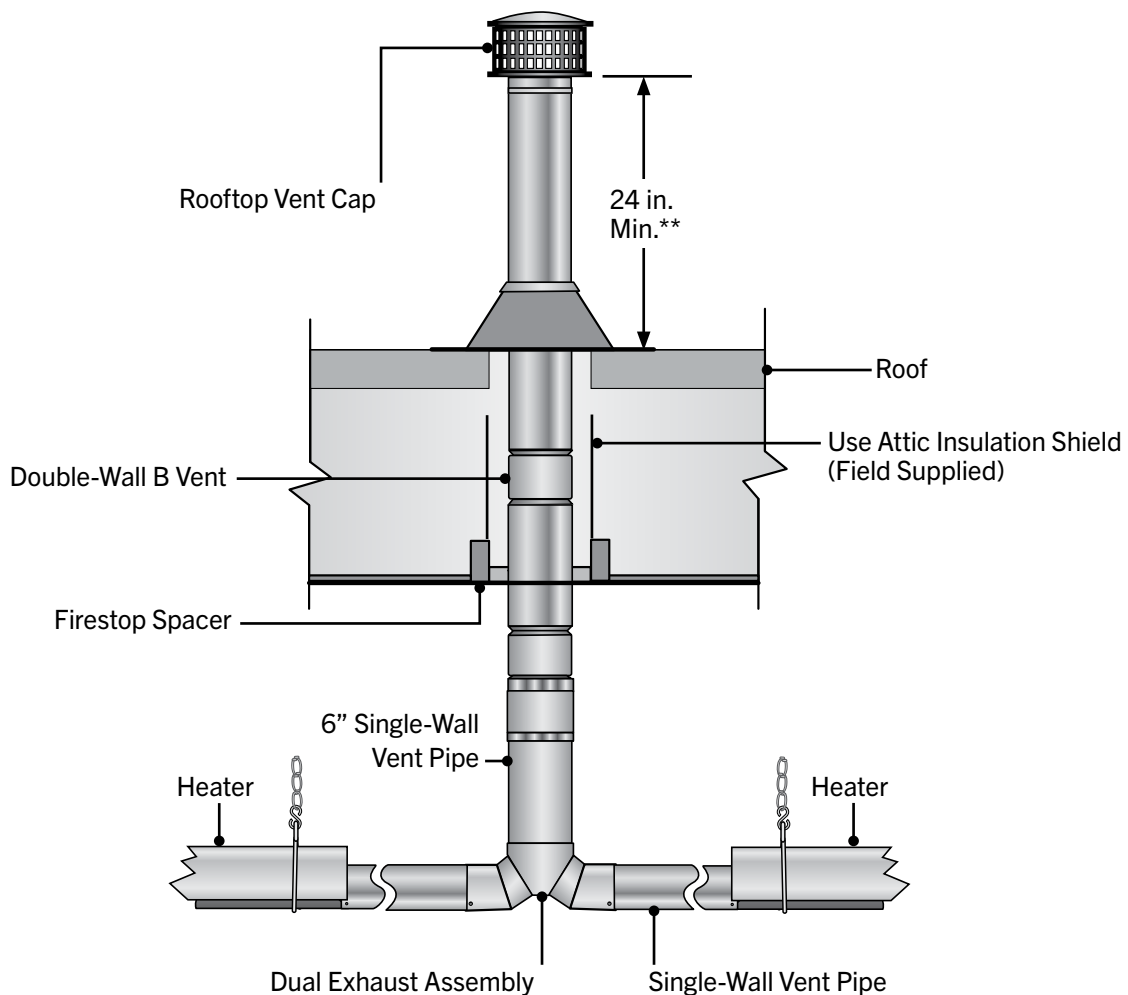

**Consult the NFPA ANSI Z223.1 Gas Vent Termination criteria if roof pitch exceeds 9:12.

Common Venting (Category III)

- A staggered arrangement or a dual exhaust assembly (P/N: Y) must be used when joining two heaters to a common vent so that by-products of one heater do not flow into the adjoining vent of the other heater.
- A Category III appliance may be common vented **only if** the appliances are on the same control device so that they may only be operated at the same time to prevent the backflow of exhaust gases into a non-operational appliance. The venting system must follow all guidelines for Category III venting as listed on pages 28-29.
- 6" diameter double-wall type B-vent and 6" vent cap (P/N: SWD-6) must be used.
- The vent connector should be routed in the most direct route from the units to the common vent.
- Where two or more vent connectors enter a common gas vent or chimney flue, the smaller connector shall enter at the highest level consistent with the available head room or clearance to combustible material.
- Restrictions within the common vent such as elbows should be minimized. Each elbow installed within the common portion of the vent carrying system reduces the maximum common vent capacity by 10%. Refer to NFPA 54 IFEC tables 13.2(a) through 13.2(e) for capacity.
- The vent connector capacities allow for the use of two 90° directional changes. For each additional required elbow, the vent connector capacity is reduced by 10%.
- The common vent cross sectional area must be equal to or greater than the largest vent connector cross sectional area.

Figure 3.24 • Common Sidewall Venting - Top View

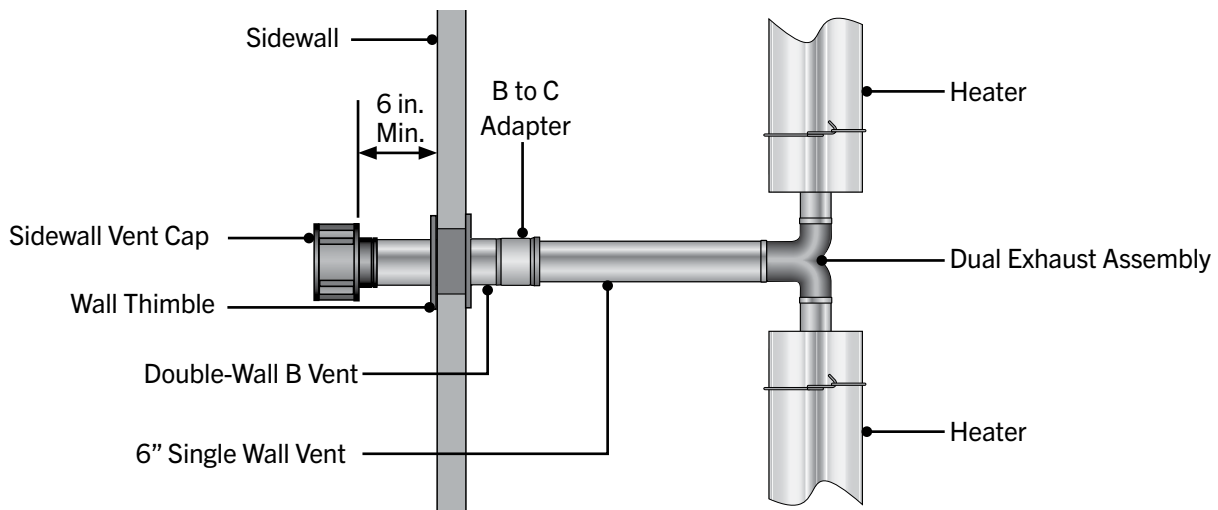

Optional Unvented Operation

⚠ WARNING



Not for residential use. The use of unvented tube heaters in residential indoor spaces may result in property damage, serious injury, or death. Use unvented operation in commercial and industrial installations with proper ventilation rates only.

When using an unvented configuration (commercial & industrial use only), **consider the following:**

- A factory vent cap/diffuser (P/N: WVE-GALV) **must** be used.
- Where unvented heaters are used, natural or mechanical means **must** be provided to supply and exhaust a minimum of 4 CFM/1,000 BTU/h input of installed heaters.

NOTE: Gravity or mechanical means may be used to accomplish the air displacement. Local codes may require that the mechanical exhaust system be interlocked with the electrical supply line to the heaters, enabling both to function simultaneously.

- The minimum clearance between the air intake and the exhaust terminal is 4 feet.

NOTE: When installing in a U-tube configuration, use extra caution to separate vent gases from heater intake.

- Exhaust openings for removing the flue products must be located above the level of the heater(s).

Figure 3.25 • Minimum End Clearances

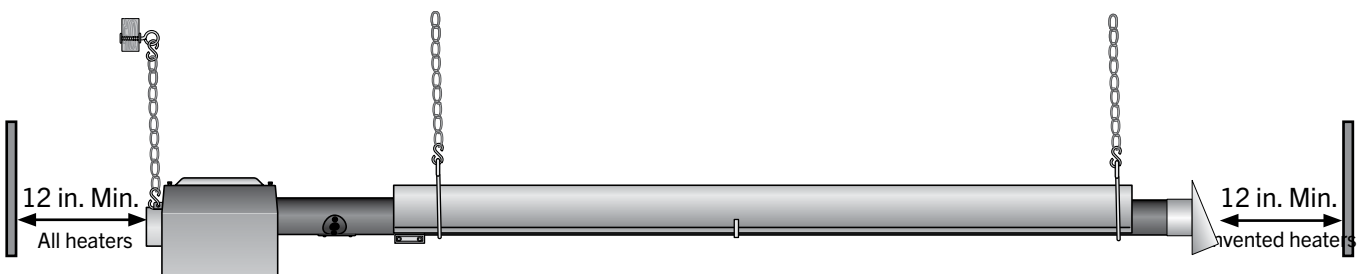

Combustion Air Requirements

Combustion air may be supplied to the heater by indoor or outdoor means.

If using combustion air intake from indoors, the required volume of the space must be a minimum of 50 ft³ per 1,000 BTU/h (4.8 m³/kW) unless the building is of unusually tight construction. If the building is of unusually tight construction with air infiltration rates of less than 0.40 air changes per hour, outside combustion air is typically needed unless the sheer size of the building allows otherwise. Contact the factory for further determination of air infiltration rates.

Non-contaminated outside air for combustion must be ducted to the heater if any of the following apply:

- Chemicals such as chlorinated or fluorinated hydrocarbons (typical sources are refrigerants, solvents, adhesives, degreasers, paints, paint removers, lubricants, pesticides, etc.).
- High humidity.
- Contaminants such as sawdust, welding smoke, etc.
- Negative building pressure.
- Unusually tight construction where there is an air infiltration rate of less than 0.40 air changes per hour.

Combustion air intake may be located on either the sidewall or roof (see figure 3.26 - 3.28).

Figure 3.26 • Vertical Outside Air Supply for Single Heater Intake - Side View

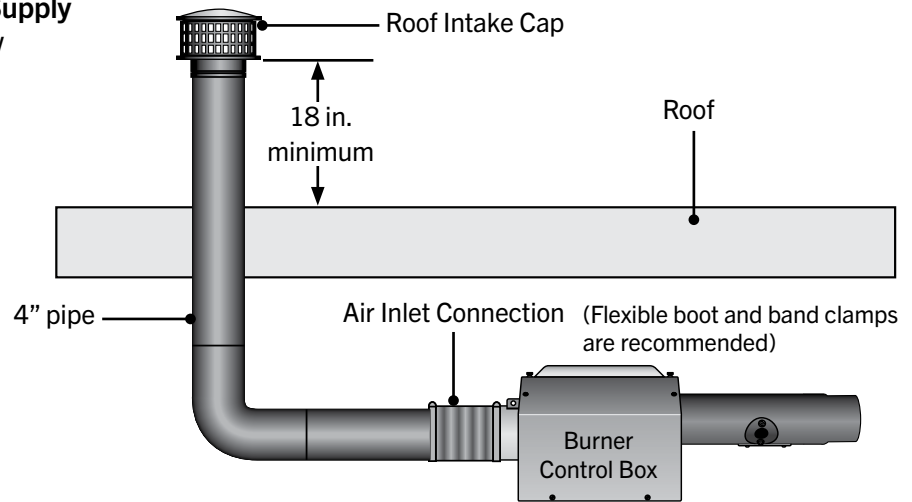

Figure 3.27 • Horizontal Outside Air Supply for Single Heater Intake - Side View

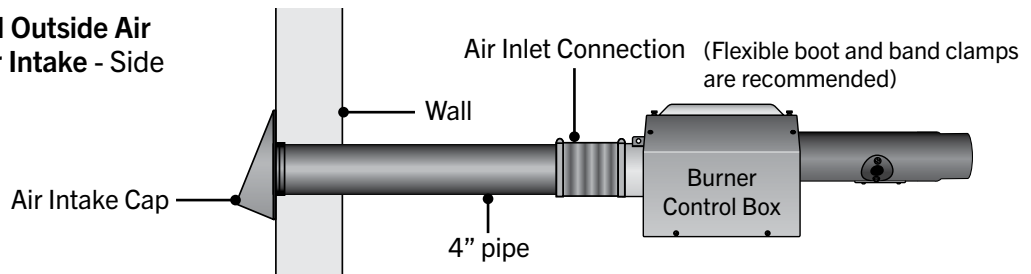
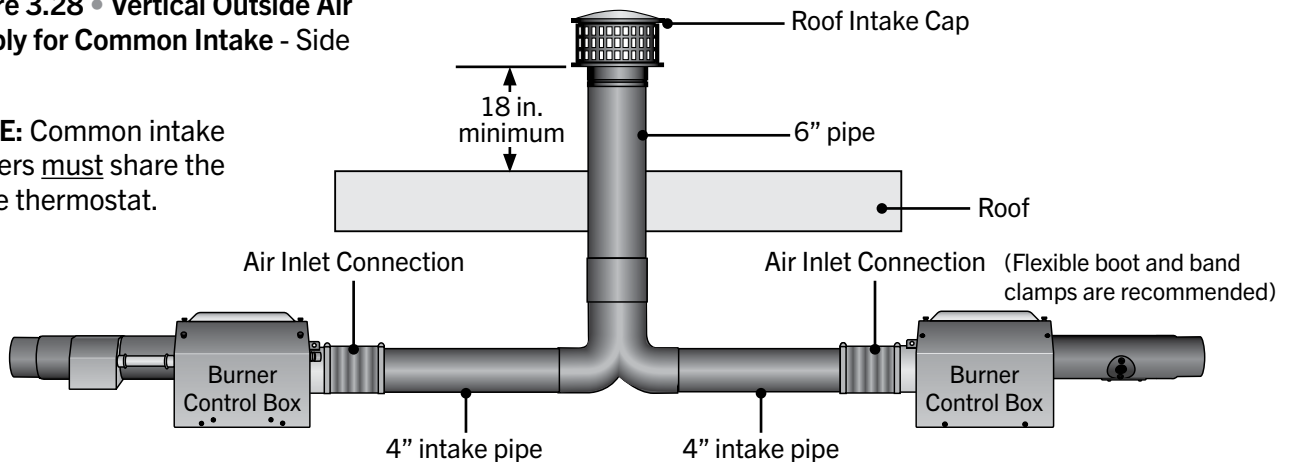

Figure 3.28 • Vertical Outside Air Supply for Common Intake - Side View

NOTE: Common intake heaters must share the same thermostat.



Guidelines:**Chart 3.7 • Limitations for Length and Size of Combustion Air Intake Duct**

Single Heater Intake		Dual Heater Intake	
Air Intake Duct Size	Max. Intake Length	Duct Size	Max. Intake Length
4 in.	20 ft.	4 in. (single)/6 in. (dual)	20 ft.
5 in.	30 ft.	4 in. (single)/8 in. (dual)	30 ft.
6 in.	40 ft.	Consult factory for longer intake lengths.	

General

- No more than two 90° elbows are allowed.
- Allow for expansion. Use a 4 inch flexible hose to connect the duct to the burner control box.
- In humid environments, use insulated duct, PVC pipe, or DWV (drain waste vent) to prevent condensation on the outer surface.
- Do not draw air from attic space.
- A factory approved wall intake cap (P/N: WIV-4) must be used with horizontal outside intake ducts. The wall intake cap (P/N: WIV-4) must be installed to prevent blockage. Locate the intake where dirt, steam, snow, etc. will not contaminate or clog the intake screen.
- Separate air intake duct from vent pipe a minimum of 4 feet. Also, place vent pipe higher than adjacent air intake duct.

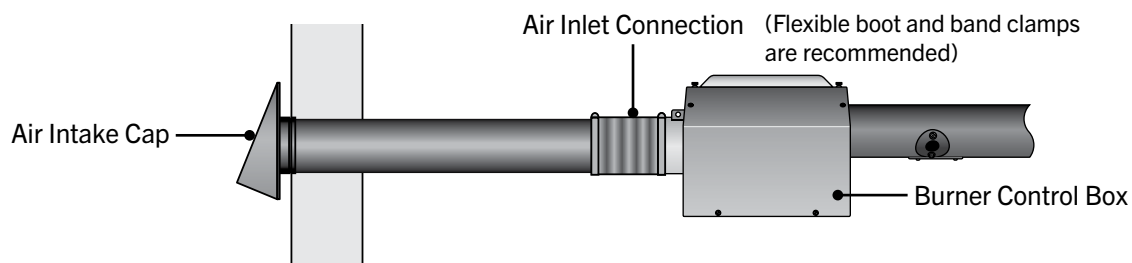
**Gas Supply****⚠ WARNING**

Improperly connected gas lines may result in fire, explosion, poisonous fumes, toxic gases, asphyxiation, or death. Connect gas lines in accordance with national, state, provincial, and local codes.

Important! Before connecting the gas supply to the burner control box:

- Verify that the heater's gas type (as listed on the rating plate) matches that of your application.
- Check that the gas piping and service has the capacity to handle the total gas consumption of all heaters being installed, as well as any other gas appliances being connected to the supply line.
- Check that the main gas supply line is of proper diameter to supply the required fuel pressures.
- If utilizing used pipe, verify that its condition is clean and comparable to a new pipe. Test all gas supply lines in accordance with local codes.

- Test and confirm that inlet pressures are correct. Refer to the heater rating plate for gas type and the required minimum and maximum pressures (see Chart 3.8). The gas supply pipe must be of sufficient size to provide the required capacity and inlet pressure to the heater (if necessary, consult the local gas company). Do not exceed the maximum allowed pressures for the heater, the space or the gas piping system.

Chart 3.8 • Manifold Pressure

Type of Gas	Required Manifold Pressure	Minimum Inlet Pressure	Maximum Inlet Pressure
Natural	3.5 Inches W.C.	5.0 Inches W.C.	14.0 Inches W.C.
Propane	10.0 Inches W.C.	11.0 Inches W.C.	14.0 Inches W.C.

NOTE: Check manifold pressure at the tap on the gas valve. Small variations in manifold pressure (actual vs. published) may exist due to changing atmospheric conditions. Readings will be above atmospheric pressure.

Pressure Equivalents: 1 inch W.C. equals .058 oz/sq. in. equals 2.49 mbar.

To connect the gas:

 **WARNING**



Failure to install, operate, or service this appliance in the approved manner may result in property damage, injury, or death. Only trained, qualified gas installation and service personnel may install or service this equipment.

The installation must conform with local building codes or, in the absence of such codes, the National Fuel Code (NFPA 54) and in conjunction with ANSI Z21.24/CSA 6.10 “Connectors for Gas Appliances”.

Important! The heating system will expand and contract during operation. Allowances for expansion must be made between the connection to the heater and the gas supply. Excessive bending, kinks, twists, or vibration must be avoided. A flexible gas connection of approved type is required. Flexible stainless steel gas connectors installed in one plane, and without sharp bends, kinks, or twists is recommended.

The gas pipe and connection **must** be supported independently. Do not install gas supply line in a manner that bears the weight of the heater. Connect the main gas supply line with an approved flexible connector (Figure 3.29) or, if national or local codes require rigid piping, a swing joint. See the safety messages at the beginning of this section.

The gas outlet must be in the same room as the appliance and accessible. It may not be concealed within or run through any wall, floor, or partition. When installing the heater in a corrosive environment (or near corrosive substances), use a gas connector suitable for the environment. Do not use the gas piping system to electrically ground the heater.

- 1 Install a sediment trap / drip leg if condensation may occur at any point of the gas supply line. This will decrease the possibility of loose scale or dirt in the supply line entering the heater’s control system and causing a malfunction. **NOTE: For high pressure gas above 14” W.C., a high pressure regulator and ball valve must be utilized and located upstream of the flex connector.**

- ② Form the stainless steel flexible connector (supplied) into a smooth C-shape allowing 12 in. between the flexible connector's end nuts (see figure 3.29).
- ③ Attach a ball valve (field supplied) to the gas supply pipe. Apply pipe compound to NPT adapter threads to seal the joint. Use only a pipe compound resistant to the type of gas to be utilized.

NOTE: Provide a 1/8 in. NPT plugged tapping accessible for test gauge connection immediately upstream of gas connection to the heater (typically provided on ball valve).

⚠ CAUTION

When using a stainless steel flexible connector, **do not** attach the connector nuts directly to the gas pipe supply. Connector nuts must be installed to an approved adapter.

- ④ Attach the flexible connector to the adapter and burner control box inlet. Seal the joints.

NOTE: Excessive torque on the manifold may misalign the orifice. **Always** use two wrenches to tighten mating pipe connections.
- ⑤ Final assembly must be tested for gas leaks according to NFPA 54 and all local codes and/or Standards.

⚠ WARNING



Testing for gas leaks with an open flame or other sources of ignition may lead to a fire or explosion and cause serious injury or death. Test in accordance with NFPA or local codes.

Figure 3.29 • Gas Connection (Flexible Gas Connection shown) - Side View

NOTE: Do not exceed 14 Inches W.C. to the appliance.

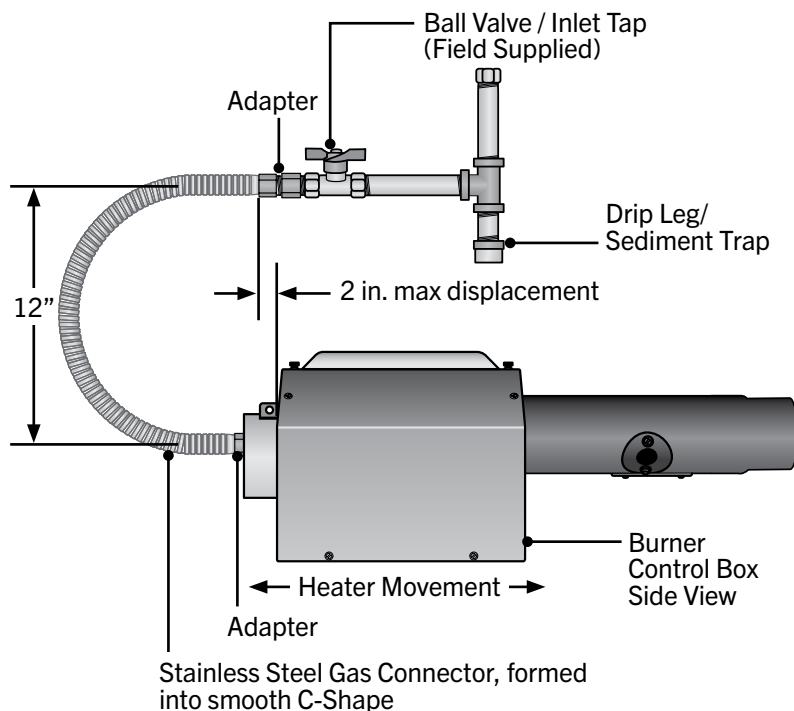
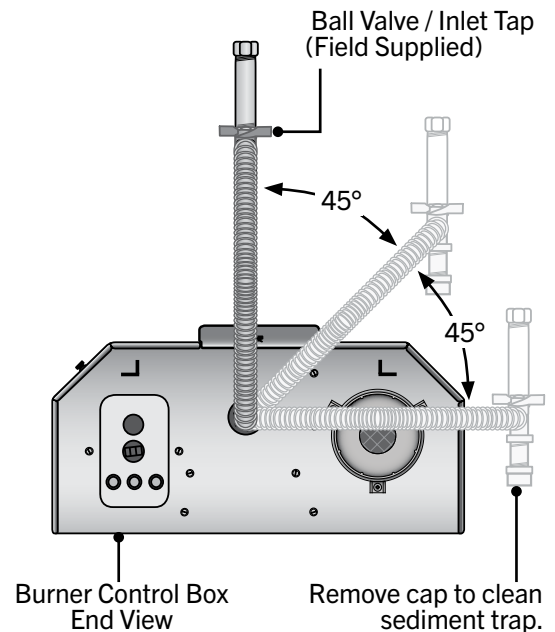

Figure 3.30 • Gas Connection (Flexible Gas Connection shown) - End View



4.0 Operation

WARNING



This heater is not equipped with a pilot ignition system.
Do not attempt to light the system manually.

Refer to the Series Insert Manual for any specific directions (e.g., single stage, two stage operation, relight after a failure, etc.).

Lighting Procedures:

- 1 Verify that service lid is secured.
- 2 Open (turn on) gas supply to the heater.
- 3 Close (turn on) electrical circuit (typically thermostat).
- 4 If the heater fails to light, turn off gas, open electrical circuit (set thermostat to lowest setting or to off). Wait five (5) minutes before repeating above steps.

Shutdown Procedures:

- 1 Open (turn off) electrical circuit.
- 2 Close (turn off) gas supply to the heater.
- 3 Wait five (5) minutes before relighting heater.

5.0 Maintenance

⚠ WARNING



Personal injury or death may result if maintenance is not performed by properly trained gas installer or service personnel. Contact the installing distributor or place of purchase for service. **Do not operate heating system if repairs are necessary.**



Allow heater to cool prior to servicing.
Disconnect power to heater before servicing.
Use protective glasses when maintaining the heater.

Routine Inspection:

At least once per year, the heating system should be inspected and serviced by trained gas installation and service personnel only. This inspection should be performed at the beginning of the heating season to ensure that all heater components are in proper working order and that the heating system operates at peak performance. Particular attention should be paid to the following items.

- **Blower Motor:** Annual oiling of the blower motor with SAE oil will extend bearing life significantly. Motors with sealed ball bearings (no oil ports) do not require oiling. Ensure that the squirrel cage in the blower is kept clean. If dirt becomes a problem, installation of outside air intake ducts for combustion is recommended.

Check lubrication instructions on motor. If oiling is required, add three to four drops of SAE 20 electric motor oil:

- After three years or 25,000 hours of operation (light-duty).
- After two years or 8,000 hours of operation (medium-duty).
- Annually or after 1,500 hours of operation (heavy-duty).

NOTICE

Never over-oil the motor or premature failure may occur.

- **Vent pipe system:** Check the outside termination and the connections at the heater. Inspect the vent exhausts for leakage, damage, fatigue, corrosion, and obstructions. If dirt becomes a problem, installation of outside air intake ducts for combustion is recommended.
- **Combustion air intake system** (when applicable): Check for blockage and/or leakage. Check the outside termination and the connection at the heater.
- **Heat exchangers:** Check the integrity of the heat exchangers. Replace if there are signs of structural failure. Check for corrosion and/or buildup within the tube exchanger passageways.
- **Burner:** Check for proper ignition, burner flame, and flame sense. Flame should extend directly outward from burner without floating or lifting.
- **Wiring:** Check electrical connections for tightness and/or corrosion. Check wires for damage.
- **Gas Connection:** Inspect the integrity of the gas connection to the heater. Check for leaks, damage, fatigue, or corrosion. Do not operate if repairs are necessary and turn off gas supply to the heater. Contact service personnel.
- **Reflectors:** Inspect the integrity of the reflectors for damage, separation, missing, or misaligned sections. Do not operate if repairs are necessary. Repair or replace as required per the general installation manual. To maintain effective infrared heating, always keep both sides of the reflector clean. Dirt and dust can be vacuumed up or wiped with a soap and water solution. Use metal polish if the reflectors are severely dirty.

Contact service personnel if repairs are necessary. Do not operate unit.

Chart 5.1 • Troubleshooting Guide

Symptom	Possible Cause	Corrective Action
Thermostat closed, fan doesn't operate.	<ul style="list-style-type: none"> • Blown fuse. • Faulty thermostat. • Loose or disconnected wire. • Faulty fan. 	<ul style="list-style-type: none"> • Replace. • Replace. • Repair as required. • Lubricate, repair or replace.
Thermostat closed. Fan operates. Switch does not close.	<ul style="list-style-type: none"> • Loose or disconnected wire. • Box lid or gasket not in place. • Plugged pressure switch lines. • Plugged or restricted exhaust vent. • Baffle location incorrect. • Faulty pressure switch. 	<ul style="list-style-type: none"> • Repair as required. • Put in place. • Clean as necessary. • Remove foreign matter. • Re-position baffles at vent end. • Replace only. Do not adjust.
Thermostat closed. Fan operates. Pressure switch closes. No glo-bar igniter.	<ul style="list-style-type: none"> • Faulty glo-bar igniter. • Faulty circuit board. 	<ul style="list-style-type: none"> • Replace. • Replace.
Thermostat closed. Fan operates. Pressure switch close. Glo-bar energizes. Valve does not open.	<ul style="list-style-type: none"> • Disconnect gas valve wires. • Faulty circuit board. • Faulty gas valve. 	<ul style="list-style-type: none"> • Repair as required. • Replace. • Replace.
Thermostat closed. Fan and glo-bar / spark igniter operate. Ignition occurs, burner cycles off in less than 60 seconds.	<ul style="list-style-type: none"> • Low gas pressure. • Baffle improperly positioned. • Faulty pressure switch. • Restricted flue vent. • No electrical ground. • Reversed polarity. 	<ul style="list-style-type: none"> • Provide required gas pressure. • Re-position baffle at vent end. • Replace. • Remove foreign matter. • Connect electrical ground to junction box. • Repair.
Thermostat closed. Fan and glo-bar / spark igniter operate. After 45 seconds glo-bar shuts off (15 seconds for spark igniter). No ignition.	<ul style="list-style-type: none"> • Closed gas supply. • Dirty or restricted orifice. • Faulty valve. Disconnected wire. • Inlet pressure exceeds 14 inches W.C. 	<ul style="list-style-type: none"> • Open all gas connections. • Remove. Clean with a soft object. • Replace or repair. • Lower inlet pressure.
Loss of heater efficiency.	<ul style="list-style-type: none"> • Low gas pressure. • Dirty or restricted orifice. • Foreign matter inside burner. • Unit cycles on and off. • Reflector is dirty. • Reflector not in place. • Clogged fan blower. 	<ul style="list-style-type: none"> • Provide required gas pressure. • Remove. Clean with a soft object. • Clean as necessary. • Check previous symptom. • Clean with aluminum cleaner and soft cloth. • Put in place. • Clean.
Radiant tube leaking burnt gases.	<ul style="list-style-type: none"> • Loose tube connections. • Holes or cracks in radiant tubes. 	<ul style="list-style-type: none"> • Ensure that tubes are fully connected and clamped properly. • Replace.
Condensation.	<ul style="list-style-type: none"> • Stack length is too long. • Light gauge vent stack used. • Contaminated combustion air. 	<ul style="list-style-type: none"> • Shorten stack length. • Minimum of 26 ga. vent pipe required. • Provide fresh air inlet duct.
Tube bowing.	<ul style="list-style-type: none"> • Insufficient combustion air. • Over fired. • Contaminated combustion air. • Heater unable to expand properly. 	<ul style="list-style-type: none"> • Provide 1 sq. in. of free air for every 5,000 BTU/h of input. • Check gas pressure and orifice size. • Provide fresh air inlet duct. • Remount with flexible inlet or vent pipe.
Tube corroding.	<ul style="list-style-type: none"> • Contaminated combustion air. 	<ul style="list-style-type: none"> • Provide fresh air inlet duct.
Visual inspection of burner operation not possible.	<ul style="list-style-type: none"> • Dirty or sooted sight glass. • Unit mounted upside-down. 	<ul style="list-style-type: none"> • Remove, clean, or replace. • Mount correctly.
Stack sooting.	<ul style="list-style-type: none"> • Insufficient combustion air. • Improper gas. • Dirty fan or blockage. 	<ul style="list-style-type: none"> • Provide 1 sq. in. of free air for every 5,000 BTU/h of input. • Correct with proper gas input (or clean).
Odor or fumes in space (normal during first firing and will subside after initial burn off, approximately 20 minutes).	<ul style="list-style-type: none"> • Vaporized solvents decomposing when contacting radiant tubes. • Evaporation of oils, solvents at floor level. • Loose tube / vent connections. 	<ul style="list-style-type: none"> • Provide proper ventilation. • Provide proper ventilation. • Tighten tube clamps to 40-60 ft-lb. • Seal vent pipes.

6.0 Limited Warranty

Limited Warranty: Radiant Tube Heaters covered in this manual, are warranted by Detroit Radiant Products Company to the original user against defects in workmanship or materials under normal use for one or three years after date of purchase. See specific product warranties in the Series Insert Manual that accompanied this piece. Any part which is determined to be defective in material or workmanship and returned to an authorized service location, as Detroit Radiant Products Company designates, shipping costs prepaid, will be, as the exclusive remedy, repaired or replaced at Detroit Radiant Products Company's option. For limited warranty claim procedures, see PROMPT DISPOSITION below. This limited warranty gives purchasers specific legal rights which vary from jurisdiction to jurisdiction.

Additional Limited Warranty: In addition to the above mentioned limited warranty, Detroit Radiant Products Company warrants the original purchaser an additional extension on the combustion chamber, radiant tubes and stainless steel burner. This extension excludes electrical/purchased components. See specific product warranties in the Series Insert Manual that accompanied this piece.

General Conditions: The Company will not be responsible for labor charges for the analysis of a defective condition of the heater or for the installation of replacement parts. The warranties provided herein will not apply if the input of the heater exceeds the rated input at time of manufacturing or if the heater in the judgment of the Company has been subjected to misuse, excessive dust, improper conversion, negligence, accident, corrosive atmospheres, excessive thermal shock, excessive vibration, physical damage to the heater, alterations by unauthorized service personnel, operation contrary to the Company's instructions or if the serial number has been altered, defaced, or removed. The Company shall not be liable for any default or delay in the performance of these warranties caused by contingency beyond its control, including war, government restriction or restraints, strikes, fire, flood, short or reduced supply of raw materials, or parts.

The warranties herein shall be null and void if the heater is not installed by a competent heating contractor and/or if the heater is not installed according to Company instructions, normal industry practices and/or if the heater is not maintained and repaired according to Company's instructions. Normal product degradation and wear (rust, oxidation, etc.) does not constitute a material defect and applicable warranty claim.

Limitation of Liability: To the extent allowable under applicable law, Detroit Radiant Products Company's liability for consequential and incidental damages is expressly disclaimed. Detroit Radiant Products Company's liability in all events is limited to and shall not exceed the purchase price paid.

Warranty Disclaimer: Detroit Radiant Products Company has made a diligent effort to provide product information and illustrate the products in this literature accurately; however, such information and illustrations are for the sole purpose of identification, and do not express or imply a warranty that the products are merchantable, or fit for a particular purpose, or that the products will necessarily conform to the illustrations or descriptions. Except as provided below, no warranty or affirmation of fact, expressed or implied, other than as stated in the LIMITED WARRANTY above is made or authorized by Detroit Radiant Products Company.

Product Suitability: Many jurisdictions have codes and regulations governing sales, construction, installation, and/or use of products for certain purposes, which may vary from those in neighboring areas. While Detroit Radiant Products Company attempts to assure that its products comply with as many codes, it cannot guarantee compliance, and cannot be responsible for how the product is installed or used. Before purchase and use of a product, review the product applications, and all applicable national and local codes and regulations, and be sure that the product, installation, and use will comply with them. Certain aspects of disclaimers are not applicable to consumer products: e.g., (a) some jurisdictions do not allow the exclusion or limitation of incidental or consequential damages, so the above limitation or exclusion may not apply to you; (b) also, some jurisdictions do not allow a limitation on how long an implied warranty lasts, consequently the above limitation may not apply to you; and (c) by law, during the period of this limited warranty, any implied warranties of implied merchantability or fitness for a particular purpose applicable to consumer products purchased by consumers, may not be excluded or otherwise disclaimed.

Prompt Disposition: Detroit Radiant Products Company will make a good faith effort for prompt correction or other adjustment with respect to any product which proves to be defective within limited warranty. For any product believed to be defective within limited warranty, first write or call dealer from whom the product was purchased. Dealer will give additional directions. If unable to resolve satisfactorily, write to Detroit Radiant Products Company at address below, giving dealer's name, address, date and number of dealer's invoice, and describe the nature of the defect. Title and risk of loss pass to buyer on delivery to common carrier. If product was damaged in transit to you file claim with carrier.



© 2026 Detroit Radiant Products Co.
21400 Hoover Road • Warren, MI 48089
Phone: (586) 756-0950 Fax: (586) 756-2626
www.detroitradiant.com • sales@drp-co.com

